

101681

U.S. Department of Justice
National Computer Law Center



National Institute
of Justice

Technology Assessment
Division

101681
189101

ABOUT THE TECHNOLOGY ASSESSMENT PROGRAM

The Technology Assessment Program is sponsored by the Office of Development, Testing, and Dissemination of the National Institute of Justice (NIJ), U.S. Department of Justice. The program responds to the mandate of the Justice System Improvement Act of 1979, which created NIJ and directed it to encourage research and development to improve the criminal justice system and to disseminate the results to Federal, State, and local agencies.

The Technology Assessment Program is an applied research effort that determines the technological needs of justice system agencies, sets minimum performance standards for specific devices, tests commercially available equipment against those standards, and disseminates the standards and the test results to criminal justice agencies nationwide and internationally.

The program operates through:

The *Technology Assessment Program Advisory Council* (TAPAC) consisting of nationally recognized criminal justice practitioners from Federal, State, and local agencies, which assesses technological needs and sets priorities for research programs and items to be evaluated and tested.

The *Law Enforcement Standards Laboratory* (LESL) at the National Bureau of Standards, which develops voluntary national performance standards for compliance testing to ensure that individual items of equipment are suitable for use by criminal justice agencies. The standards are based upon laboratory testing and evaluation of representative samples of each item of equipment to determine the key attributes, develop test methods, and establish minimum performance requirements for each essential attribute. In addition to the highly technical standards, LESL also produces user guides that explain in nontechnical terms the capabilities of available equipment.

The *Technology Assessment Program Testing and Information Center* (TAPTIC) operated by a grantee, which supervises a national compliance testing program conducted by independent agencies. The standards developed by LESL serve as performance benchmarks against which commercial equipment is measured. The facilities, personnel, and testing capabilities of the independent laboratories are evaluated by LESL prior to testing each item of equipment, and LESL helps the Information Center staff review and analyze data. Test results are published in Consumer Product Reports designed to help justice system procurement officials make informed purchasing decisions.

Publications issued by the National Institute of Justice, including those of the Technology Assessment Program, are available from the National Criminal Justice Reference Service (NCJRS), which serves as a central information and reference source for the Nation's criminal justice community. For further information, or to register with NCJRS, write to the National Institute of Justice, National Criminal Justice Reference Service, Washington, DC 20531.

James K. Stewart, Director
National Institute of Justice

9 mm/45 Caliber Autoloading Pistols

NIJ Standard-0112.00

April 1986

101681

U.S. Department of Justice
National Institute of Justice

This document has been reproduced exactly as received from the person or organization originating it. Points of view or opinions stated in this document are those of the authors and do not necessarily represent the official position or policies of the National Institute of Justice.

Permission to reproduce this copyrighted material has been granted by

~~Public Domain/NIJ~~

~~US Department of Justice~~

to the National Criminal Justice Reference Service (NCJRS).

Further reproduction outside of the NCJRS system requires permission of the copyright owner.

**U.S. DEPARTMENT OF JUSTICE
National Institute of Justice**

James K. Stewart, Director

ACKNOWLEDGMENTS

This standard was formulated by the Law Enforcement Standards Laboratory (LESL) of the National Bureau of Standards under the direction of Daniel E. Frank, Manager, Protective Equipment Program and Lawrence K. Eliason, Chief of LESL. The technical research was performed by Nicholas J. Calvano, Automated Production Technology Division. The standard has been reviewed and approved by the Technology Assessment Program Advisory Council.

The technical effort to develop this standard was conducted under Interagency Agreement LEAA-J-IAA-021-3, Project No. 8103.

FOREWORD

This document, NIJ Standard-0112.00, 9 mm/45 Caliber Autoloading Pistols, is an equipment standard developed by the Law Enforcement Standards Laboratory of the National Bureau of Standards. It is produced as part of the Technology Assessment Program of the National Institute of Justice. A brief description of the program appears on the inside front cover.

This standard is a technical document that specifies performance and other requirements equipment should meet to satisfy the needs of criminal justice agencies for high quality service. Purchasers can use the test methods described in this standard to determine whether a particular piece of equipment meets the essential requirements, or they may have the tests conducted on their behalf by a qualified testing laboratory. Procurement officials may also refer to this standard in their purchasing documents and require that equipment offered for purchase meet the requirements. Compliance with the requirements of the standard may be attested to by an independent laboratory or guaranteed by the vendor.

Because this NIJ standard is designed as a procurement aid, it is necessarily highly technical. For those who seek general guidance concerning the selection and application of law enforcement equipment, user guides have also been published. The guides explain in nontechnical language how to select equipment capable of the performance required by an agency.

NIJ standards are subjected to continuing review. Technical comments and recommended revisions are welcome. Please send suggestions to the Program Manager for Standards, National Institute of Justice, U.S. Department of Justice, Washington, DC 20531.

Before citing this or any other NIJ standard in a contract document, users should verify that the most recent edition of the standard is used. Write to: Chief, Law Enforcement Standards Laboratory, National Bureau of Standards, Gaithersburg, MD 20899.

Lester D. Shubin
Program Manager for Standards
National Institute of Justice

NIJ STANDARD FOR 9 mm/45 CALIBER AUTOLOADING PISTOLS

CONTENTS

	Page
Foreword	iii
1. Purpose and Scope	1
2. Classification	1
3. Definitions	1
4. Requirements	5
4.1 Acceptance Criteria	5
4.2 User Information	5
4.3 Visual Inspection	5
4.4 Dimensional Requirements	6
4.5 Functional Requirements	6
4.6 Firing Requirement	6
4.7 Drop Safety Requirement	7
4.8 Drop Function Requirement	7
5. Test Methods	7
5.1 Sampling	7
5.2 Special Test Equipment	7
5.3 Visual Inspection	7
5.4 Dimensional Tests	8
5.5 Function Tests	8
5.6 Firing Test	10
5.7 Drop Safety Test	11
5.8 Drop Function Test	12
Appendix A—Other Considerations	13

COMMONLY USED SYMBOLS AND ABBREVIATIONS

A	ampere	H	henry	nm	nanometer
ac	alternating current	h	hour	No.	number
AM	amplitude modulation	hf	high frequency	o.d.	outside diameter
cd	candela	Hz	hertz (c/s)	Ω	ohm
cm	centimeter	i.d.	inside diameter	p.	page
CP	chemically pure	in	inch	Pa	pascal
c/s	cycle per second	ir	infrared	pe	probable error
d	day	J	joule	pp.	pages
dB	decibel	L	lambert	ppm	part per million
dc	direct current	L	liter	qt	quart
$^{\circ}\text{C}$	degree Celsius	lb	pound	rad	radian
$^{\circ}\text{F}$	degree Fahrenheit	lbf	pound-force	rf	radio frequency
diam	diameter	lbf-in	pound-force inch	rh	relative humidity
emf	electromotive force	lm	lumen	s	second
eq	equation	ln	logarithm (natural)	SD	standard deviation
F	farad	log	logarithm (common)	sec.	section
fc	footcandle	M	molar	SWR	standing wave ratio
fig.	figure	m	meter	uhf	ultrahigh frequency
FM	frequency modulation	min	minute	uv	ultraviolet
ft	foot	mm	millimeter	V	volt
ft/s	foot per second	mph	mile per hour	vhf	very high frequency
g	acceleration	m/s	meter per second	W	watt
g	gram	N	newton	λ	wavelength
gr	grain	N·m	newton meter	wt	weight

area=unit² (e.g., ft², in², etc.); volume=unit³ (e.g., ft³, m³, etc.)

PREFIXES

d	deci (10 ⁻¹)	da	deka (10)
c	centi (10 ⁻²)	h	hecto (10 ²)
m	milli (10 ⁻³)	k	kilo (10 ³)
μ	micro (10 ⁻⁶)	M	mega (10 ⁶)
n	nano (10 ⁻⁹)	G	giga (10 ⁹)
p	pico (10 ⁻¹²)	T	tera (10 ¹²)

COMMON CONVERSIONS

(See ASTM E380)

ft/s \times 0.3048000 = m/s
 ft \times 0.3048 = m
 ft·lbf \times 1.355818 = J
 gr \times 0.06479891 = g
 in \times 2.54 = cm
 kWh \times 3 600 000 = J

lb \times 0.4535924 = kg
 lbf \times 4.448222 = N
 lbf/ft \times 14.59390 = N/m
 lbf-in \times 0.1129848 = N·m
 lbf/in² \times 6894.757 = Pa
 mph \times 1.609344 = km/h
 qt \times 0.9463529 = L

Temperature: $(T_{\text{F}} - 32) \times 5/9 = T_{\text{C}}$

Temperature: $(T_{\text{C}} \times 9/5) + 32 = T_{\text{F}}$

NIJ STANDARD FOR 9 mm/45 CALIBER AUTOLOADING PISTOLS

1. PURPOSE AND SCOPE

This standard establishes performance requirements and test methods for pistols to be used by law enforcement officers. It addresses 9 mm and 45 caliber single and double action pistols only. The standard is intended for use in assessing the acceptability of new or reissue* autoloading pistols. This standard does not address specific safety devices, full or partial magazine release, pistol shot group size (accuracy), nor sights. (See app. A for a discussion of these topics.)

2. CLASSIFICATION

The pistols covered by this standard are considered to be a single classification.

3. DEFINITIONS

3.1 Barrel Bore

The diameter of the largest inscribed circle that can be placed inside the barrel.

3.2 Double Action

A mode of operation that permits the trigger to cock and fire the pistol. (See also single action.)

3.3 Firing Malfunction

Failure to feed, fire, or eject a round. This is a subset of a malfunction.

3.4 Grip Safety

A passive safety device that requires an applied force on the grip before the pistol can be fired.

3.5 Hammer Spur

Extension of the hammer used to cock the hammer manually.

3.6 Headspace

The space between the breech face and the part of the chamber that prevents forward movement of the cartridge.

*All pistols must be examined and reconditioned as necessary by a trained armorer or gunsmith prior to reissue.

3.7 Headspace Gage

A device used to facilitate measurement of headspace. (See figs. 1 through 4.)

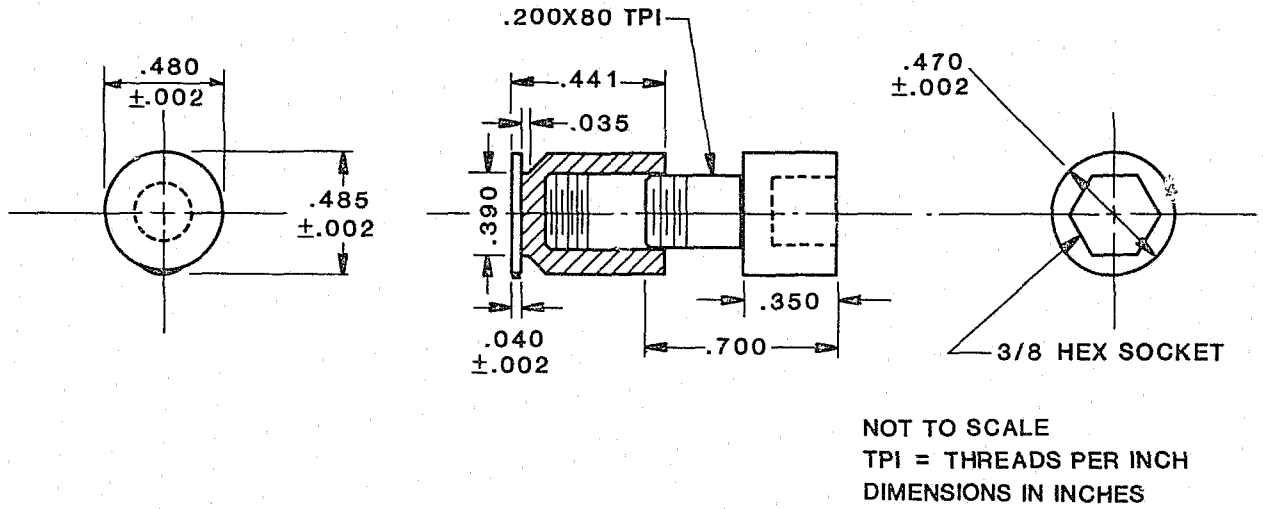

FIGURE 1. 9 mm Luger adjustable headspace gage.

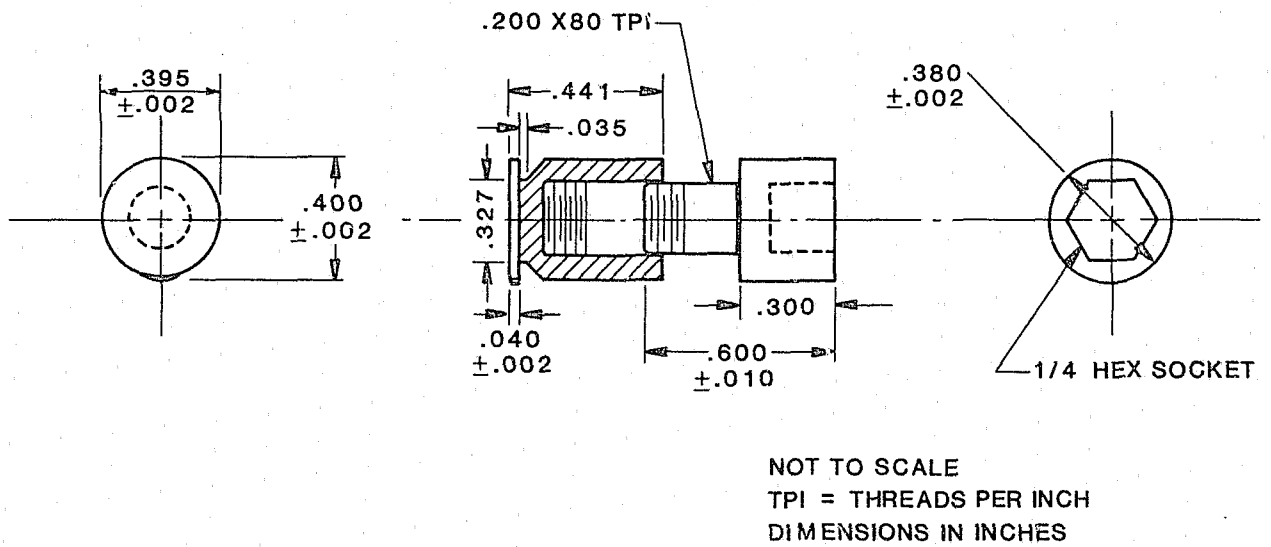

FIGURE 2. .45 Automatic adjustable headspace gage.

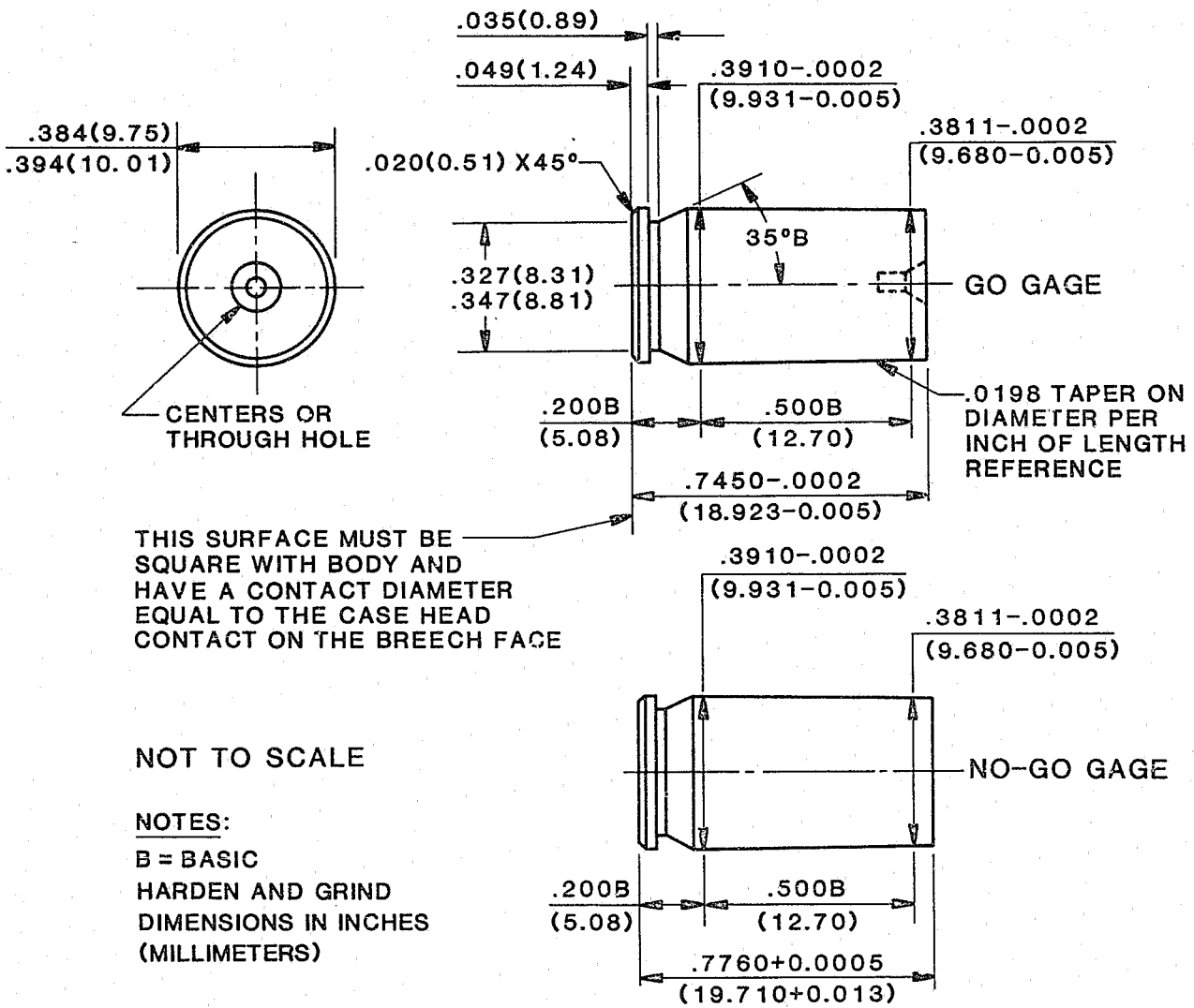

FIGURE 3. Go, no-go gages for 9 mm Luger.

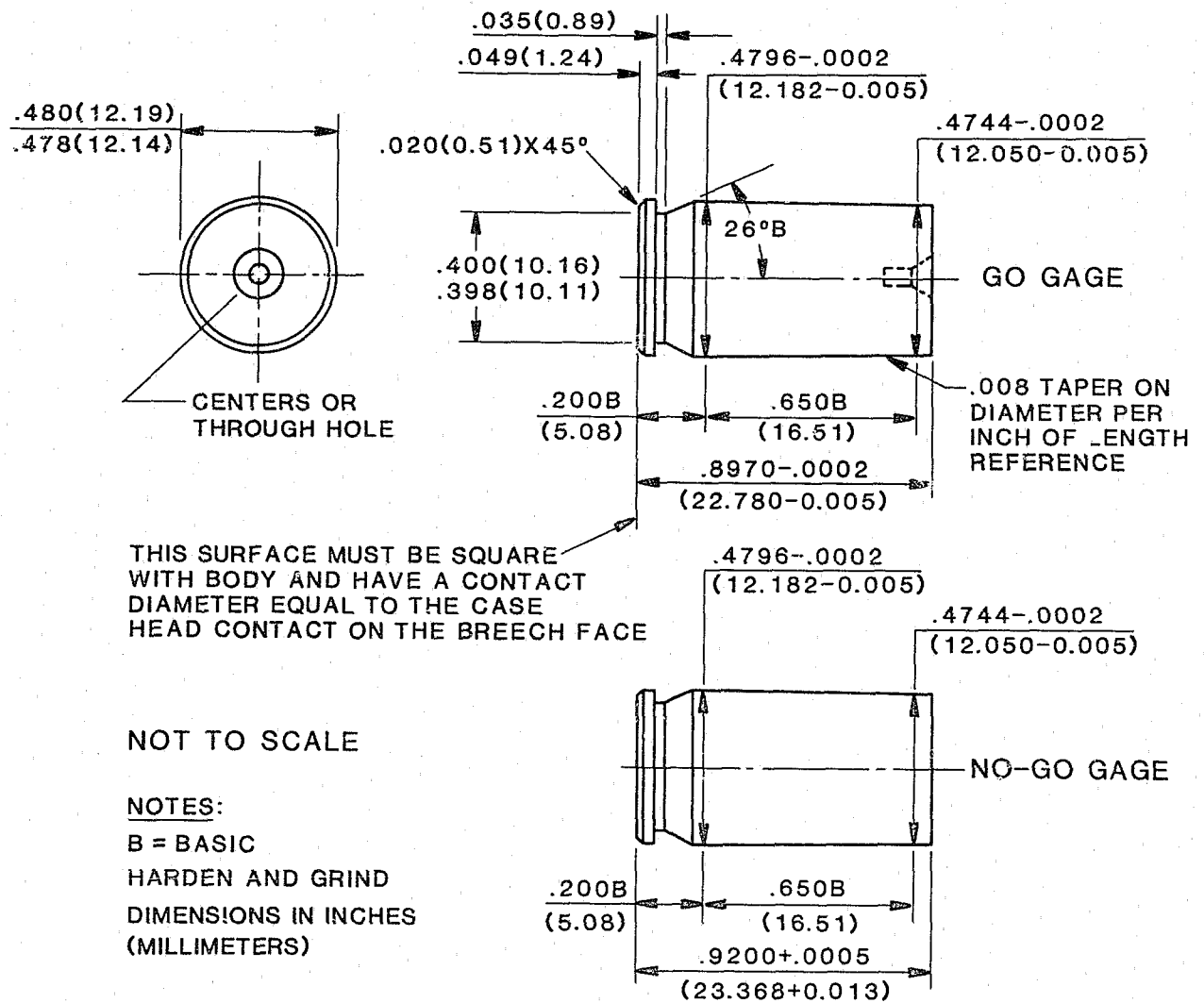

FIGURE 4. Go, no-go gages for 45 Automatic.

3.8 Magazine Safety

A passive safety device that prevents firing of the pistol unless a magazine is in place.

3.9 Malfunction

Failure to feed, fire, or eject a round or failure to accept or eject a magazine; or failure of the slide to remain open after the magazine has been expended.

3.10 Misfire

Failure to fire a round. (See firing malfunction and malfunction.)

3.11 Single Action

A mode of operation that uses the trigger to fire the pistol only. (See also double action.)

3.12 Trigger Pull

The force that must be applied to the trigger to fire the pistol.

4. REQUIREMENTS

4.1 Acceptance Criteria

To satisfy the requirements of this standard, both sample pistols (see sec. 5.1) must pass all of the requirements and tests specified in this standard.

To be suitable for reissue, a pistol model that has previously met the requirements of this standard must be reconditioned by an armorer or gunsmith and as a minimum meet the visual inspection requirements (sec. 4.3), the dimensional requirements (sec. 4.4), the functional requirements (sec. 4.5), and the reissue firing requirement (sec. 4.6.2).

4.2 User Information

The following information must be supplied by the manufacturer:

- a. Instructions for field disassembly/assembly and diagrams identifying all parts.
- b. Cleaning instructions.
- c. As minimum, a description of each safety feature designed into the pistol, how each safety feature is intended to function, and for those under shooter control, how the shooter should operate (activate/deactivate) each safety feature.
- d. A statement on ammunition known to be beyond the design limits of the pistol (e.g., +P ammunition in a pistol not designed to handle +P ammunition) and/or known not to function in the pistol.
- e. A parts list and ordering instructions.
- f. Certification of compliance with this standard.

4.3 Visual Inspection

4.3.1 Hammer Travel

In the single action mode, the hammer shall have sufficient overtravel to assure achievement of the full cocked position.

4.3.2 Particles

There shall be no loose shavings nor filings in the pistol.

4.3.3 Surface

The pistol shall have no chips, scratches, burrs, nor rust spots. There shall be no sharp edges nor corners that could cut the shooter's hand while firing or during manual cycling of the pistol. The pistol shall be

inherently rust resistant (e.g., stainless steel), or the pistol shall have a protective finish.

4.4 Dimensional Requirements

4.4.1 Barrel Bore Diameter

The barrel bore diameter shall be not less than 8.64 mm (0.340 in) nor more than 8.92 mm (0.351 in) for the 9 mm and not less than 10.87 mm (0.428 in) nor more than 11.30 mm (0.445 in) for the 45 cal.

4.4.2 Headspace

The headspace shall be not less than 18.92 mm (0.745 in) nor more than 19.71 mm (0.776 in) for the 9 mm and not less than 22.78 mm (0.897 in) nor more than 23.37 mm (0.920 in) for the 45 cal. when measured in accordance with section 5.4.2.

4.5 Functional Requirements

4.5.1 Action

The slide shall operate smoothly without binding or sticking when operated by hand or during firing tests (see secs. 5.5.1 and 5.6) and after the drop function tests (see sec. 5.8).

4.5.2 Ejection

The ejection mechanism shall eject cases without hangup during the firing tests (sec. 5.6) and after the drop function tests (sec. 5.8) except as provided in sections 4.6 and 4.8.

4.5.3 Trigger

- a. The single action trigger pull force shall be not less than 13 N (3 lbf*) nor more than 36 N (8 lbf) when tested in accordance with section 5.5.3.
- b. The double action trigger pull force shall be no more than 80 N (18 lbf) when tested in accordance with section 5.5.3.

4.5.4 Hammer

When tested in accordance with section 5.5.4, the hammer shall operate smoothly without binding and shall not release under an applied load of 45 ± 1 N ($10 \frac{1}{4} \pm \frac{1}{4}$ lbf).

4.5.5 Safety Features

The pistol shall have one or more design features to prevent inadvertent firing. Active safety devices shall be designed so that the pistol can be made fire-ready by releasing the safety(s) with the shooting hand.

The pistol shall not fire when tested in accordance with section 5.5.5.

4.5.6 Magazine

The magazine shall have a capacity of six rounds, minimum, and shall be capable of being released without removing the shooting hand from the pistol.

4.6 Firing Requirement

4.6.1 Model Qualification Firing Requirement

When tested in accordance with section 5.6.1 the pistol shall fire 600 rounds of ammunition with no structural or mechanical failures and no more than five malfunctions. Of the five allowable malfunctions no more than three shall be firing malfunctions not attributable to faulty ammunition (see sec. 5.6).

* N, the preferred unit of force, is equal to 0.2248 lbf. For the purpose of this standard all conversions from Newton to pound-force for required values and measurements have been rounded to the nearest 1/4 lbf.

4.6.2 Reissue Firing Requirement

The pistol shall function with the ammunition used by the issuing department when tested in accordance with section 5.6.2. The department is free to increase the number of rounds to be fired. However, the minimum number of rounds that are required is equal to twice the maximum capacity of a magazine times the number of magazines issued with the pistol. For tests of 200 rounds or less, there shall be no more than one malfunction not attributable to faulty ammunition.

4.7 Drop Safety Requirement

The pistol shall not fire during the drop test described in section 5.7.

4.8 Drop Function Requirement

The pistol shall exhibit no more than three malfunctions when tested in accordance with section 5.8.

5. TEST METHODS

5.1 Sampling

Two representative samples of each pistol model to be tested are required. The samples can be selected at random from the current purchase lot for acceptance testing, recognizing that the two tested pistols probably will not be suitable for field issue after testing. NOTE: The pistols must be examined by a trained armorer or gunsmith after testing and reconditioned as necessary if issue of these two pistols is contemplated. Alternatively, two test pistols can be supplied by the manufacturer for qualification compliance testing separately from the purchase lot, in which case they shall be selected randomly from the current production.

5.2 Special Test Equipment

5.2.1 Adjustable Headspace Gage

The adjustable headspace gage is manufactured from hardened steel and precision ground to the dimensions shown in figure 1 for autoloading pistols chambered for 9 mm Luger ammunition and figure 2 for autoloading pistols chambered for 45 Automatic ammunition.

5.2.2 Go, No-Go Headspace Gages

These headspace gages are hardened steel rods, precision ground to the dimensions shown in figure 3 for autoloading pistols chambered for 9 mm Luger ammunition and figure 4 for autoloading pistols chambered for 45 Automatic ammunition.

5.3 Visual Inspection

Verify that the pistol is unloaded.

5.3.1 Hammer

Cock the external hammer, if one is present, to the single action full-cock position. Verify that there is perceptible travel past this position.

5.3.2 Particles

Examine the pistol. Note any shavings or filings that should not be inside the pistol.

5.3.3 Surface

Examine the pistol's surfaces. Note any chips, scratches, sharp edges, burrs, or rust spots. Verify that the pistol is protected from rusting.

5.4 Dimensional Tests

5.4.1 Barrel Bore Diameter

Measure the diameter of the largest circle that can be inscribed in the bore of the barrel at the muzzle.

5.4.2 Headspace

Insert a headspace gage into the chamber, release the slide slowly until the slide stops and extend the gage until it rests against the recess in the chamber (fig. 5). Remove the gage and measure its length to obtain headspace. Alternatively, use two gages (go, no-go) machined to the minimum and maximum tolerances (fig. 3 or 4). The slide must close completely over the minimum tolerance gage but not over the maximum tolerance gage. Do not force gages nor allow the mechanism to slam shut on a gage since one or the other may be damaged.

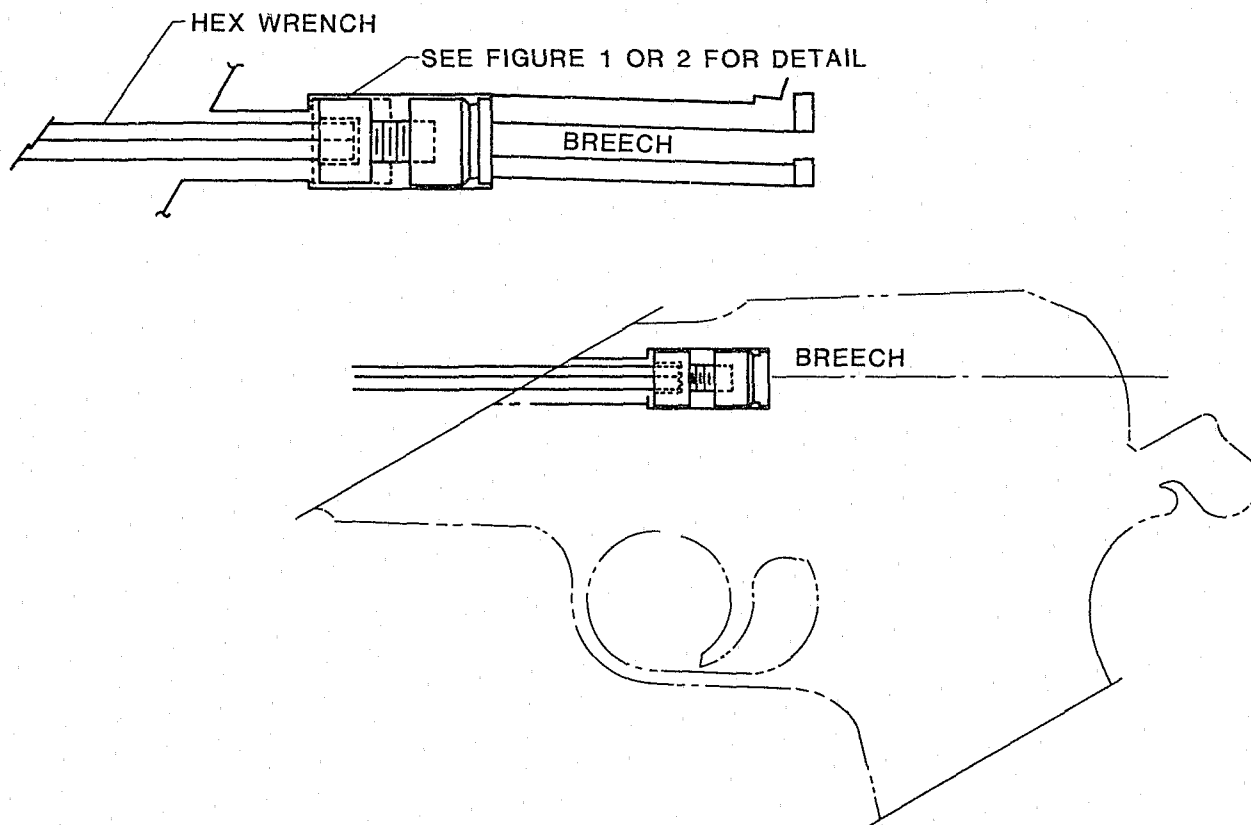

FIGURE 5. *Headspace gage usage.*

5.5 Function Tests

5.5.1 Action

- a. Operate the unloaded pistol in all of its action modes.
 - b. Pull the slide fully to the rear and release it to battery position.
- In each case note any sticking, binding, grittiness, or hesitation.

5.5.2 Ejection Test

Load the pistol with a full magazine of ammunition and then fire the full load into a bullet trap or other suitable device. Note any failure to eject and whether the slide remains open after the last round.

5.5.3 Trigger Pull Test

With the pistol empty, apply a load to the rearmost part of the front surface of the trigger so that the load is parallel to the barrel to within 5° (fig. 6).

a. Single action.

Cock the hammer or striker. Apply a 12-N (2 3/4 lbf) load to the trigger and uniformly increase it in 1-N (1/4 lbf) increments until the load of 36 N (8 lbf) has been applied or until the hammer releases.

b. Double action.

With the hammer or striker down, apply a 40-N (9 lbf) load to the trigger and uniformly increase it in 1-N (1/4 lbf) increments until a load of 80 N (18 lbf) has been applied or until the pistol cocks and fires on the empty chamber.

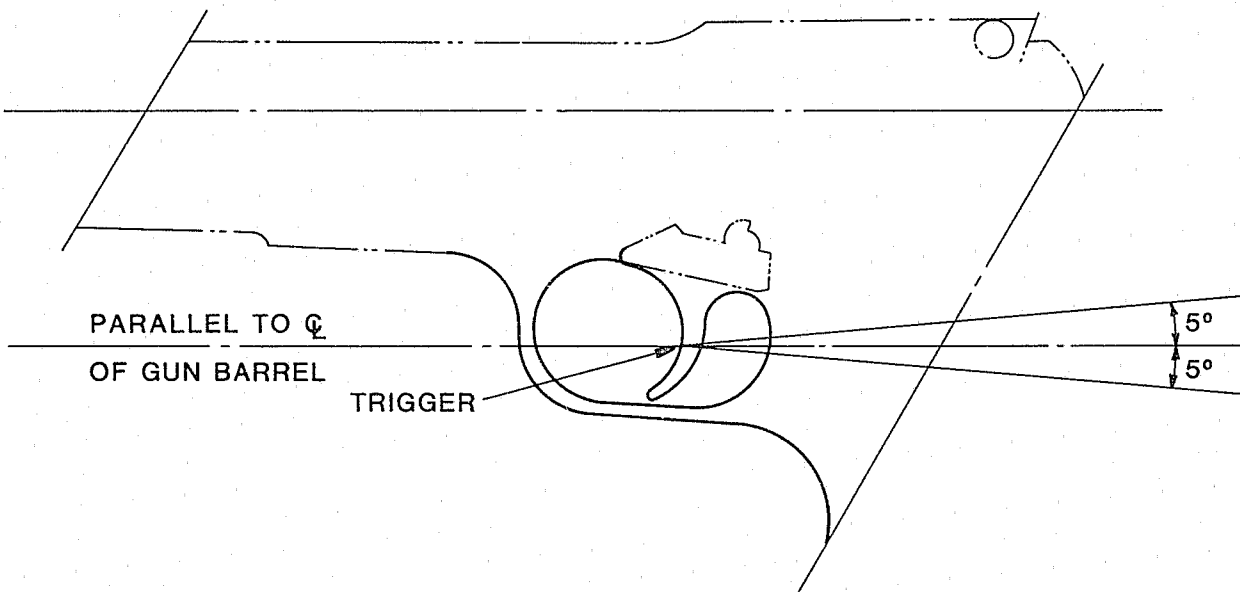

FIGURE 6. *Trigger pull test.*

5.5.4 Hammer Test

With the pistol empty, cock the hammer and release it by pulling the trigger several times to check for smoothness of operation. Fully cock the hammer and load it with a 45 ± 1 N ($10 \frac{1}{4} \pm \frac{1}{4}$ lbf) force applied to the rearmost part of the hammer spur and tangential to hammer's arc (fig. 7).

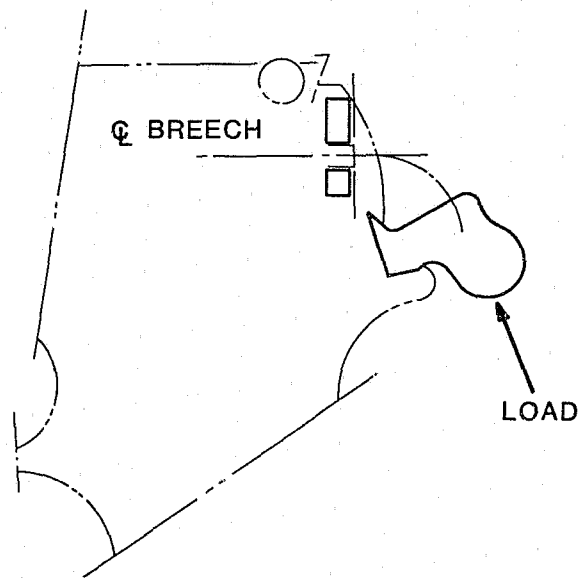

FIGURE 7. *Hammer test setup.*

5.5.5 Safety Features Test

Obtain from the manufacturer a description of the design feature(s) included in the pistol to ensure that the pistol will discharge only through the proper operation of the trigger mechanism, the list of parts that implement the design feature(s), and the manner in which the safety feature(s) operate. Verify that all of the safety parts are present, that they operate in the manufacturer's intended manner, and that the feature(s) perform their intended function.

Chamber a primed case (no powder or projectile), engage the safety device and attempt to fire into a bullet trap or other suitable device to determine whether the round discharges. If a pistol has more than one safety device, disengage all but one to conduct the test. Repeat, using the second safety device. Continue in this manner until all safety devices have been tested. In some designs the removal of parts to disable one safety feature may affect the performance of another safety feature. If assistance is needed to test each safety feature independently, consult with the manufacturer.

5.5.6 Magazine Test

Check the ease of insertion and removal of the magazine(s) by inserting each unloaded magazine into the pistol and releasing it in accordance with the manufacturer's instructions. Note any binding or sticking during insertion and release.

5.6 Firing Test

5.6.1 Model Qualification Firing Test

Fire a total of 600 rounds, 400 rounds of 115 gr blunt nosed hollow point and 200 rounds of 124 gr round nose full metal jacket in 9 mm Luger. Fire a total of 600 rounds, 400 rounds of 185 gr blunt nosed hollow point and 200 rounds of 230 gr round nose full metal jacket in 45 Automatic. For double action pistols, fire the first round of each magazine in double action mode. Before firing, examine the pistol for defects such as loose screws, cracks, etc. After every 200 rounds tighten any loose screws, and measure trigger pull (sec. 5.5.3) and headspace (sec. 5.4.2). Also, determine from the manufacturer how, without firing the pistol, to lower the hammer when there is a live round in the pistol's chamber. Generally, this is accomplished through the use of a safety lever; however, it is necessary to be sure of the correct procedure.

Place an empty magazine in the pistol, pull the slide all the way to the rear, and verify that the slide hold open mechanism operates. Remove the magazine from the pistol and verify that the slide remains open. Load the magazine to maximum capacity, point the pistol at a suitable bullet trap, and insert the loaded magazine into the pistol. Release the slide hold open mechanism to chamber a round. For double action pistols, lower the hammer so that the first shot can be fired in double action mode. Fire into a bullet trap or other suitable device until the magazine is empty. Fire the first six rounds in 5 s. The firing rate for the remainder of the test must be at least one round every 2 s and no greater than two rounds per second. Increments of 100 rounds must be fired with no delays except to reload or to determine causes of malfunctions.

Note all misfires and whether the pistol ejects and feeds properly. Also observe whether the slide remains in the open position after the last round in the magazine has been fired.

After each magazine has been emptied, check the release mechanism for easy removal of the magazine. Check for smooth easy insertion of the reloaded magazine.

If feed or release problems are experienced during the first 50 rounds, replace the magazine and continue testing to determine whether the problems were caused by a faulty magazine. If a faulty magazine is suspected, note that the magazine was suspect and begin testing again at round zero with the new magazine.

Should three or more misfires occur during the 600 round test sequence, examine the primers in the misfired cartridges. If it is obvious that the misfires are the fault of the pistol (e.g., very shallow or no indentation of the primer), the pistol has failed to meet the requirements of the standard. If it is not obvious that the misfires are the fault of the pistol, repeat the entire firing test as stated above, except that the dimensional measurements (headspace, trigger pull) need not be made. If the pistol passes the second 600 round test it meets the requirements. If three or more misfires occur during the second 600 rounds, and again it is not clearly the fault of the pistol, the ammunition manufacturer should be consulted to determine the condition of the misfired ammunition.

5.6.2 Reissue Firing Requirement

Perform the firing test of section 5.6.1 using the department's standard issue ammunition and the magazine(s) that will be issued with the pistol. If there is more than one magazine, each magazine is to be used an equal number of times. The dimensional measurements (headspace, trigger pull) need not be made.

Should there be too many malfunctions proceed as in section 5.6.1 to determine if the ammunition is at fault.

5.7 Drop Safety Test

Pull the slide fully rearward and lock it in the rear position. Insert a primed case (no powder or projectile) into the chamber. Release the slide, allowing it to move forward under the impetus of the recoil spring. Insert an empty magazine and place the pistol in a drop fixture capable of dropping the pistol from a drop height of $1\text{ m} + 1\text{ cm} - 0$ ($39.4 + 0.4\text{ in} - 0$) onto the largest side of a slab of solid concrete having minimum dimensions $7.5 \times 15 \times 15\text{ cm}$ ($3 \times 6 \times 6\text{ in}$). The drop distance is measured from the lowermost portion of the pistol to the top surface of the slab. The pistol shall not be dropped from a hand: a fixture is required. However, the pistol shall be dropped in the condition (i.e., cocked, no manual safety applied, etc.) that the pistol would be in if it were dropped from a hand. If the design of the pistol is such that upon leaving the hand a "safety" is automatically applied by the pistol, this feature shall not be defeated. One fixture found to be suitable consists of a short piece of string with the pistol attached at one end and the other end held in an air vise until the drop is initiated.

The following six drops are required:

1. Normal firing position; barrel horizontal.
2. Upside down; barrel horizontal.
3. On grip; barrel vertical.
4. On muzzle; barrel vertical.
5. On either side; barrel horizontal.
6. If there is an exposed hammer or striker, on the rearmost point of that device; otherwise on the rearmost point of the pistol.

Examine the primer for indentations after each drop. If indentations are present, a fresh primed case must be used for the next drop. Firing of the primer constitutes failure of the test.

5.8 Drop Function Test

After completing the drops specified in the drop safety test (sec. 5.7), examine the pistols for damage and note any cracks, chips, or other visible damage. For those pistols that passed the drop safety test without structural damage, insert a fully loaded magazine, chamber a round, point the pistol into a bullet trap or other suitable device. It is recommended that the pistol be placed in a suitable holding fixture and fired remotely. Fire until the ammunition has been expended. Release the magazine (note any sticking or binding), reload and repeat until 20 rounds have been fired. Note any misfires or malfunctions. If there are more than three malfunctions, repeat the 20 round firing test. If there are no more than three malfunctions during the repeat firing test, the pistol meets the requirements; otherwise it fails.

APPENDIX A—OTHER CONSIDERATIONS

SAFETY DEVICES

Firing Pin Block

A firing pin block is an internal mechanism that positively locks the firing pin away from the cartridge primer unless the trigger is held fully to the rear. The operation of this safety feature is transparent to the shooter, i.e., requires no action on the shooter's part other than normal operation of the pistol. However, a firing pin block of proper design improves the safeness of a pistol when dropped or when the operation of the pistol is not normal (such as the hammer or striker falling unintentionally due to mechanical failure or if the pistol is dropped in such a way that the inertia of a noncaptive firing pin would fire the pistol).

Magazine Safety

The magazine safety precludes firing the pistol unless the magazine is inserted. An obvious advantage of this device is elimination of the possibility of accidentally firing a round in the chamber when the weapon is thought to be empty with the magazine removed. A less obvious disadvantage of the magazine safety is that an officer cannot load and fire the pistol if the magazine has been lost or does not function due to damage.

Lever Safety

The lever safety is generally located on the side of the pistol where it can be reached easily with the right thumb. This is fine for right-handed shooters. For law enforcement officers who are left-handed or if the right hand is injured, the safety must be released with the nonshooting hand—a sometimes awkward and inefficient procedure.

Grip Safety

The grip safety, a lever located on the front or back of the grip, is a passive device. Its purpose is generally to render the pistol safe if it is dropped. However, in at least two pistol designs, such levers are used to fully ready the pistol for firing in addition to acting as a safety feature. This device offers the advantage of automatically rendering the pistol safe as soon as the loaded and cocked pistol leaves the hand. However, its purpose can be defeated while the pistol is being carried in some holsters, hence care must be exercised.

MAGAZINE RELEASE

The user is provided with two choices of magazine release: partial-release and full-release. The full-release completely separates the magazine from the pistol when the release button is pressed. The partial-release separates the magazine only partially; complete removal is accomplished by manually pulling the magazine from the grip.

The full-release system offers the advantage of more rapid reload capability. However, the possibility of losing or damaging the magazine upon release is much greater with this system. While the partial-release system may be a little slower for reloading, it greatly reduces the likelihood of damage or loss of magazines upon release. If full-release systems are chosen, magazines used for practice should be kept separate from duty magazines.

ACCURACY

Accuracy is a measure of the gun's ability to place a group of bullets on a target and is a function of both ammunition and gun. With the sights adjusted for a given distance and using controlled ammunition, an "accurate" gun has the capability of consistently firing bullets in a tight random pattern about the aim point. As accuracy falls off, the size of the pattern increases.

An important but variable factor in apparent accuracy is the shooter. With a given weapon in good mechanical condition, the scatter will be more strongly influenced by the shooter and his surroundings than anything else. This is why in accuracy tests "machine rests" are used to hold and position the pistol in an attempt to remove the human factor.

Consider, for example, firing on a target range as opposed to a confrontation with an armed assailant. On a range, the shooter knows the precise distance to the target, is not under duress, and has time to take a comfortable stance while aiming carefully to align the sights with a stationary target—ideal circumstances for small shot groups.

In contrast, consider an officer firing at an assailant who is firing back, moving, and at a distance that is unknown and changing. In this situation, the officer is under great stress, does not know the precise target distance, may be in an uncomfortable position and does not have the luxury of time to take careful aim while squeezing the trigger. Despite the fact that the gun and ammunition remain constant, one would expect the size of the shot group to be substantially larger than in the range case.

TARGETING/SIGHT CONSIDERATIONS

The exact trajectory of a bullet fired from a pistol is determined by the characteristics of the ammunition, the handgun, and the individual who fires the pistol. Sights, fixed or adjustable, are provided to enable an individual to aim the pistol, i.e., predetermine the desired point of impact of the bullet. For practical purposes, no two individuals aim a pistol by aligning the sights with the desired point of impact in exactly the same manner. As a consequence, no pistol that meets the performance requirements of the standard should be used in service until the individual to whom it has been issued "sights-it-in" using the intended service ammunition. The process of "sighting a pistol in" will often identify problems with the sights on the pistol that must be corrected to ensure suitability for service use.

The most commonly used pistol sight is the Patridge type. It consists of a rectangular notch on the rear of the pistol and a post or ramp-type blade attached to the muzzle end of the barrel. There are several special sighting systems and modifications to the Patridge sight to facilitate aiming the pistol, each of which has its own inaccuracies and potential problems.

Common problems with Patridge type sights that affect the aiming of the pistol are as follows:

- (1) The front sight may be too high, low, thick, or thin; not securely attached; or not attached in line with the frame and barrel.
- (2) The notch in the rear sight may be too wide, narrow, shallow, or deep.
- (3) The rear sight may be too high or low, not attached securely, or not attached in line with the frame and barrel.
- (4) Adjustable sights may not have sufficient adjustment in elevation or azimuth to accommodate all user and ammunition variables.

The above problems are sometimes simple to correct. Front sights that are too high or thick may be filed in place for adjustment. However, when a front sight is too thin, short, or improperly attached, the service of the factory or trained gunsmith (armorer) is required to correct the problem. When the notch of a rear sight is too high, narrow, or not securely attached, correction is generally a simple matter. However, rear sights that are already too low, wide, or not in line with the axis of the pistol should be corrected by trained personnel. Problems with adjustable rear sights that are not due to the adjusting mechanism (i.e., rear sight will move, but not enough) are usually corrected by adjusting the front (fixed) sight to accommodate the useful adjustment range of the rear sight. Some manufacturers, recognizing the difficulties associated with adding metal to a sight that is too small, have designed replaceable front sights. However, care must now be taken to assure that the front sight is solidly attached to the pistol.

Clearly, with special sighting systems, the manufacturer of the system must be consulted for assistance when the person issued the pistol cannot "sight-it-in."

Finally, it should be recognized that the pistol, ammunition, shooter, and the sights comprise a system, some parts of which are fully capable of compensating for deficiencies in other parts of the system. However, the characteristics of any part of the system can change with time, for example:

- (1) The shooter changes
 - (a) physical strength
 - (b) eyesight
- (2) The service ammunition changes
- (3) The pistol changes
 - (a) dropped but still serviceable
 - (b) normal wear and tear
 - (c) any repair work has been done.

The pistol should be sighted-in by the user before it is considered ready for service (at the time of original issue and any time that the characteristics of the ammunition, pistol, or individual issued the weapon change).

The user should pay particular attention to any problems in aiming the pistol when "sighting-it-in" prior to proficiency requalification to detect any subtle changes in pistol or personal characteristics that may have occurred since the last qualification or practice session.