

NCJRS

This microfiche was produced from documents received for inclusion in the NCJRS data base. Since NCJRS cannot exercise control over the physical condition of the documents submitted, the individual frame quality will vary. The resolution chart on this frame may be used to evaluate the document quality.

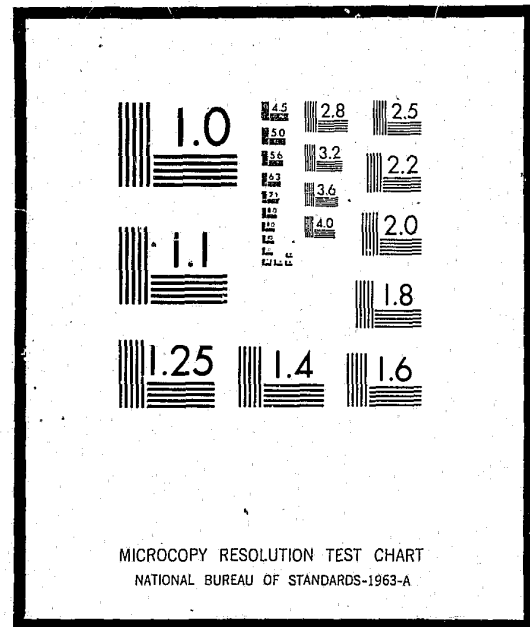

Microfilming procedures used to create this fiche comply with the standards set forth in 41CFR 101-11.504

Points of view or opinions stated in this document are those of the author(s) and do not represent the official position or policies of the U.S. Department of Justice.

U.S. DEPARTMENT OF JUSTICE
LAW ENFORCEMENT ASSISTANCE ADMINISTRATION
NATIONAL CRIMINAL JUSTICE REFERENCE SERVICE
WASHINGTON, D.C. 20531

POWER LINE ALARM TRANSMISSION SYSTEM

Final Report

January 1974

Date filmed

9/19/75

15605

THE AEROSPACE CORPORATION



Post Office Box 92957, Los Angeles, California 90009, Telephone: (213) 648-5000

To The Reader

GTE Sylvania, Inc. performed a two phase effort investigating alarm transmission capabilities of residential power lines under a subcontract from The Aerospace Corporation. The program was funded by the LEAA. The first phase was for the characterization of typical residential power wiring in terms of a transmission media, which resulted in a Phase I Report. The second phase was for the development and demonstration of a low cost passively activated alarm system concept which made use of the characterization data. This concept development is described in the subcontract Final Report.

The two documents resulting from this study (Power System Characterization and Final Report) describe what is probably the most fully documented attempt to characterize residential power wiring systems in terms of a communication transmission media. This attempt was made for the express purpose of demonstrating the feasibility of using building power lines as a reliable internal transmission component for a low cost security alarm system concept.

Much is yet to be learned before residential power wiring systems can be efficiently and widely used as a communication media. This initial study has revealed the need for more data taken on a wider geographic scale and incorporating additional types of measurements. Users of this data should be aware that for some applications additional power line spectral noise data is required, and signal insertion parameters for efficient operation have not yet been identified. The alarm industry and other potential users of this transmission media should welcome this data as a starting point for a better understanding of the opportunities associated with internal alarm communications systems utilizing residential power lines.

Law Enforcement Development Group
The Aerospace Corporation

GTE SYLVANIA INCORPORATED
ELECTRONIC SYSTEMS GROUP - WESTERN DIVISION
P. O. Box 188
Mountain View, California 94040

POWER LINE ALARM TRANSMISSION SYSTEM

Final Report

by

R. F. Bell
Dr. D. L. Hardison
V. V. Pazemenas
D. H. Rowe

Contract Number 35623

September 1973

An Equal Opportunity Employer

GENERAL OFFICES LOCATED AT: 2350 EAST EL SEGUNDO BOULEVARD, EL SEGUNDO, CALIFORNIA



To The Reader

GTE Sylvania Inc., under a subcontract from The Aerospace Corporation performed a two phase effort investigating alarm transmission capabilities of residential power lines.

The program was funded by the LEAA. The first phase was for the characterization of typical residential power wiring in terms of a transmission media, which resulted in the Phase I Characterization Report. The second phase was for the development and demonstration of a low cost passively activated alarm system concept which made use of the characterization data. This concept development is described in the final report.

The two documents resulting from this study (Power System Characterization and Final Report) describe what is probably the most fully documented attempt to characterize, and as a direct result of that characterization, use residential power wiring systems in terms of a communication transmission media. This attempt was made for the express purpose of demonstrating the feasibility of using building power lines as a reliable internal transmission component for a low cost security alarm system concept.

Much has been learned from this effort and much is yet to be learned before residential power wiring systems can be efficiently and widely used as a communication media. This initial study has revealed the need for more data taken on a wider geographic scale and incorporating additional types of measurements. Users of this data should be aware that from some applications additional power line spectral noise data is required and, as yet, signal insertion parameters for efficient operation have not been identified. The alarm industry and other potential users of this transmission media should welcome this data as a starting point for a better understanding of the opportunities associated with internal alarm communications systems utilizing residential power lines.

Law Enforcement Development Group
The Aerospace Corporation

TABLE OF CONTENTS

<u>Section</u>	<u>Title</u>	<u>Page</u>
1.0	INTRODUCTION AND SCOPE	1-1
2.0	PLATS SYSTEM CONSIDERATIONS	2-1
2.1	Design Requirements	2-1
2.2	Design Approach	2-1
2.2.1	Design Considerations	2-1
2.2.2	Computer Simulation	2-5
2.2.2.1	Power Lines as Transmission Lines	2-5
2.2.2.2	Typical Household Wiring Loads	2-8
2.2.3	Design Parameters	2-10
3.0	DESIGN IMPLEMENTATION	3-1
3.1	Block Diagram	3-1
3.1.1	Signal Generation and Coupling Circuits	3-1
3.1.2	Analog Processing Circuits	3-3
3.1.3	Digital Processing Circuits	3-6
3.1.4	Alarm Circuits	3-6
3.2	Circuit Description	3-7
3.2.1	Signal Generation and Coupling Circuits	3-7
3.2.2	Analog Processing Circuits	3-10
3.2.3	Digital Processing Circuits	3-11
3.2.4	Alarm Circuits	3-11
3.3	Shunt Impedance Switch	3-11
4.0	TESTING AND RESULTS	4-1
4.1	Test Procedure	4-1
4.2	Test Results	4-1
4.2.1	Safety Test	4-1
4.2.2	Sensitivity/Series Resistance Test	4-2
4.2.3	Active Noise Test	4-4
4.2.4	Switching Noise Test	4-4
4.2.5	Activation Time Tests	4-8
4.2.6	Alarm Verification Test	4-8

Table of Contents (Continued)

<u>Section</u>	<u>Title</u>	<u>Page</u>
4.2.7	Signal Transmission Test	4-8
4.2.7.1		4-8
4.2.7.2		4-14
4.2.7.3		4-14
4.2.8	Loading Tests	4-14
4.2.8.1		4-14
4.2.8.2		4-15
4.2.8.3		4-15
4.2.9	Line Noise Rejection Tests	4-15
4.2.9.1		4-15
4.2.9.2		4-16
4.2.9.3		4-16
4.2.10	EMI Tests	4-16
4.2.11	False Alarm Tests	4-16
4.2.12	Multiple Sensor Tests	4-17
5.0	OPERATING PROCEDURES AND LIMITATIONS	5-1
6.0	CONCLUSIONS AND RECOMMENDATIONS	6-1
6.1	Recommendations for Methods of Improvement	6-2
7.0	LOCATION/IDENTIFICATION SENSING	7-1
7.1	Problem Statement	7-1
7.2	Basic Operation	7-1
7.3	Technical Description	7-1
7.4	Message Length	7-3
7.5	Power Line Transmission	7-3
7.6	Message Structure	7-3
7.7	Modulation Type	7-4
7.8	Mutual Interference	7-5
7.9	Conclusions	7-5

LIST OF FIGURES

<u>Figure</u>	<u>Title</u>	<u>Page</u>
2-1	Simplified PLATS Block Diagram	2-4
2-2	Test 1 Circuit	2-6
2-3	Voltage Ratio in dB Between Nodes 4, 0 and 2, 0 (Test 1 Circuit)	2-7
2-4	Computer Plot of Voltage Magnitude at Node 1 in SFR1B Circuit (Household Wiring with Lamp and Heater Loads)	2-9
3-1	Receiver/Control Unit Block Diagram	3-2
3-2	Receiver/Control Unit Schematic (Sheet 1 of 2)	3-8
3-3	Receiver/Control Unit Schematic (Sheet 2 of 2)	3-9
3-4	SIS Schematic	3-12
4-1	Sensitivity/Series Resistance Test Setup	4-3
4-2	Active Noise Test Setup and Results	4-5
4-3	Switching Noise Test Setup	4-6
4-4	Activation Time Test Setup and Results	4-7
4-5	Location 2 - Wiring Configuration, CKTS 1 & 2	4-9
4-6	Location 2 - Wiring Configuration, CKTS 3 & 4	4-10
4-7	Location 2 - Wiring Configuration, CKTS 5 & 10	4-11
4-8	Location 2 - Wiring Configuration, CKT 6	4-12
4-9	Location 2 - Wiring Configuration, CKTS 7, 8, & 9	4-13
7-1	System Block Diagram	7-2

1.0 INTRODUCTION AND SCOPE

This document presents the results of work performed by GTE Sylvania Incorporated under contract to The Aerospace Corporation by the Law Enforcement Assistance Administration of the Department of Justice. The principal effort described herein is the design, fabrication and testing of a breadboard model of a residential security alarm system intended to demonstrate the feasibility of a concept of using residential power wiring passively as the communication medium within a security system. This Power Line Alarm Transmission System (PLATS) is a general purpose residential intrusion detector which utilizes the household power wiring as a medium for communication between various entry detectors and an active receiver/alarm control unit. The system was conceived as one possible solution to the high cost of effective residential burglar alarms, much of which cost is due to hardwire installation labor. The concept feasibility model design was based upon a power line characterization study performed by GTE Sylvania. Extensive characterization data was collected in this study and the results have been documented in a previous report under this same contract.

This report begins with a discussion of the system design considerations. Next is a section on the design implementation. Following this, the results of the completed test plan are presented and discussed. System limitations and recommended operating procedures are presented. These are followed by program conclusions and recommendations for additional effort on the Power Line Alarm Transmission concept. The final chapter of this report comprises a separate study effort on active power line modulation considerations and includes recommendations on the optimization of a communications system which uses active modulation of a power line carrier.

2.0 PLATS SYSTEM CONSIDERATIONS

2.1 DESIGN REQUIREMENTS

The PLATS system is intended to provide low cost intra-residential alarm transmission via the power lines. Using the power lines as a transmission medium eliminates the costly and often unsightly wiring when an alarm system is installed in a previously constructed residence.

Besides being low cost, the system should provide reliable alarm transmission and should have an extremely low false alarm rate. It should also be capable of being used in a wide variety of residential wiring systems and should not be effected by power line voltage variations, noise, and impedance changes.

Since the PLATS will be used inside residences, safety and aesthetics also become important. The potential shock hazard which is present in all power line operated devices must be eliminated, and the unit must be made as small, inconspicuous and aesthetically pleasing as possible.

Part of the eventual cost of the system would be its reliability and maintainability. It is therefore desirable to have the system as maintenance free as possible, and if maintenance is ever required, it is desirable that it could be performed by relatively low-skill technicians.

The one other desirable characteristic of the system would be its ability to be implemented using integrated circuits wherever possible to reduce cost and increase reliability. Digital techniques lend themselves easily to Large Scale Integration (LSI), but for a small system, both analog and digital techniques must be considered as being cost-effective, depending on the application.

2.2 DESIGN APPROACH

2.2.1 Design Considerations

Several designs which could meet the requirements as stated in section 2.1 were considered. Systems which had both an active transmitter and receiver were looked at first. However, since in this application, as many as 2 to 25 transmitters will be required for each receiver, transmitter cost is a major consideration.

Since the alarm system should be able to function if the AC power fails, active transmitters would have to be powered by batteries. Because of limited shelf-life, the logistics

2.2.1 (Continued)

of keeping transmitters supplied with batteries would be immense and not practical in a consumer application. Therefore, we made the decision to use a system in which the alarm transmitters were passive.

A passive approach was also considered in the original PLATS proposal. In this approach, two fixed-frequency oscillators were proposed to be used. The sense oscillator frequency would correspond to the series resonant frequency of the Shunt Impedance Switch (SIS) and the reference oscillator frequency would be as close as possible in frequency to the sense oscillator, but far enough so that its amplitude would not be affected by the SIS resonant circuit. The detector would continuously compare the output of both oscillators so that a drop in one oscillator output without a corresponding drop in the other would indicate that an SIS had been connected in shunt across the power line.

As our power system characterization phase of the program progressed, several serious limitations of such a system were discovered:

- (1) The oscillator frequencies would have to be spaced very close together (frequencies within 10% of each other) because line load fluctuations caused variations of the line impedance not only in magnitude but also in phase.
- (2) The filtering at the detector would have to be fairly complex to isolate frequencies so close together.
- (3) The SIS resonant frequency must be very accurately controlled to correspond exactly with the frequency of the sense oscillator.
- (4) Most importantly, power line characteristics effectively detuned the SIS in a manner that was dependent on the length of the power line and the number and type of loads. This made its detection when sampling only two frequencies very difficult.

2.2.1 (Continued)

A simplified block diagram of this system is shown in Figure 2-1. It consists of a Receiver/Control Unit and a Shunt Impedance Switch (SIS). The Receiver/Control Unit contains a swept frequency oscillator e_s and a detector located on the other side of the source resistor R_s . The oscillator signal is fed into the power line via some proper decoupling network in order to isolate it from the 117 volts RMS. Somewhere on the other end of the power line the SIS is connected. The SIS is normally untuned from resonance by the switch of a sensing device such as a magnetic door switch, switch mat, or any other normally open switch contact. When the switch is closed the SIS produces a series resonant trap at a frequency primarily determined by L and C. When e_s is swept through the resonant frequency of the SIS, the detector notices a marked drop in the output due to the resonant loading and sounds an alarm. Conceptually the system is extremely simple. However, implementation is complicated by the extremely complex world of the power distribution line.

The operating frequency choice was the most important consideration. We chose a frequency range from 104 to 116 kHz. This choice was based on numerous considerations:

- (a) Power line properties as transmission lines.
- (b) Power line noise spectrum.
- (c) Impedance changes due to household appliances and other types of loads.
- (d) Characteristics of utility company house feeder lines.
- (e) SIS component characteristics.

Most of the necessary information was obtained from the Power System Characterization Phase I Report and additional data was gathered from computer simulation of household wiring loads and the SIS.

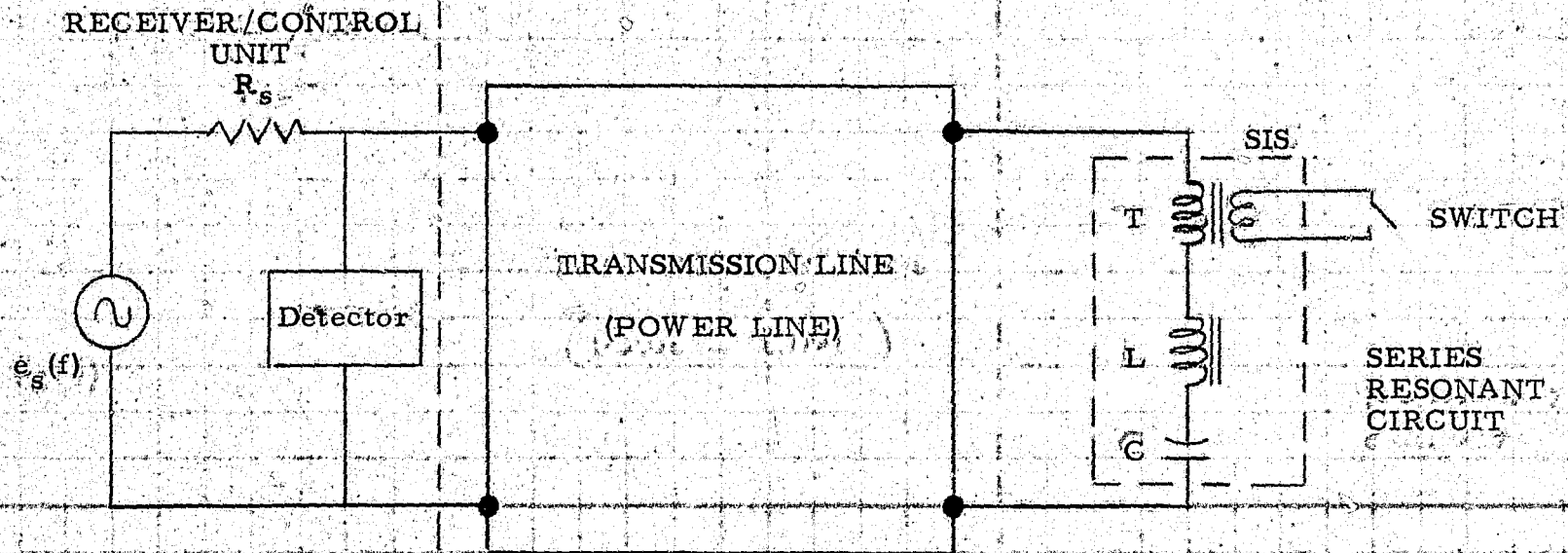

Figure 2-1. - Simplified PLATS Block Diagram

PREPARING ORIGINAL DIAGRAMS AND LAYOUTS MUST BE IN BLUE INK. ANY BLUE WILL NOT REPRODUCE.

2.2.1 (Continued)

As a result, the frequency was chosen to be a nominal 110 kHz with a ± 6 kHz sweep range. The sweep rate, another important consideration, was chosen to be approximately 2 Hz. Other parameters were chosen for reasons as specified in section 3.0.

2.2.2 Computer Simulation

2.2.2.1 Power Lines as Transmission Lines

Numerous measurements were made on typical house wiring configurations, such as Romex wire and conduit and plain wire. Some of these measurements are covered in the Phase I Report. At that time it became obvious that any model that did not consider the transmission line characteristics of household wiring would be inaccurate. Therefore, a computer model for a typical transmission line was derived from the measured characteristics using the AEDCAP computer-aided analysis program. The computer model was tested by comparing it to actual Romex measurements and found to correspond with an accuracy which was typically better than 1 dB.

A typical power line simulation with transmission lines is shown in Figure 2-2. This circuit was used to test the effect of load resistance and transmission line length on transmission characteristics.

Figure 2-3 shows a computer printout of the voltage ratio in decibels between nodes 4,0 and 2,0. The frequency range covered is between 10 kHz and 640 kHz. Numerous plots such as that shown in Figure 2-3 were generated. It appeared that these transmission line effects would get increasingly severe with increasing frequency in typical household wiring situations. This is an expected conclusion since transmission line effects are first noted when the length of the transmission line is appreciable as compared with a quarter wavelength. However, it must be kept in mind that the shunt capacitance effect is dependent on source impedance and may be significant at lower frequencies.

For the sake of standardization, the power line characteristic impedance was chosen to be 110 ohms. This value was the approximate median of the values

```
13.26.59 edit test1 ckt
NONSTANDARD FILETYPE
NEW FILE.
INPUT:
1 0 es 1.
2 0 3 0 t1 tline(121n,75.,14.5k)
3 0 4 0 t2 tline(90.6n,75.,14.5k)
1 2 rs 165.
4 0 rl 165.
```

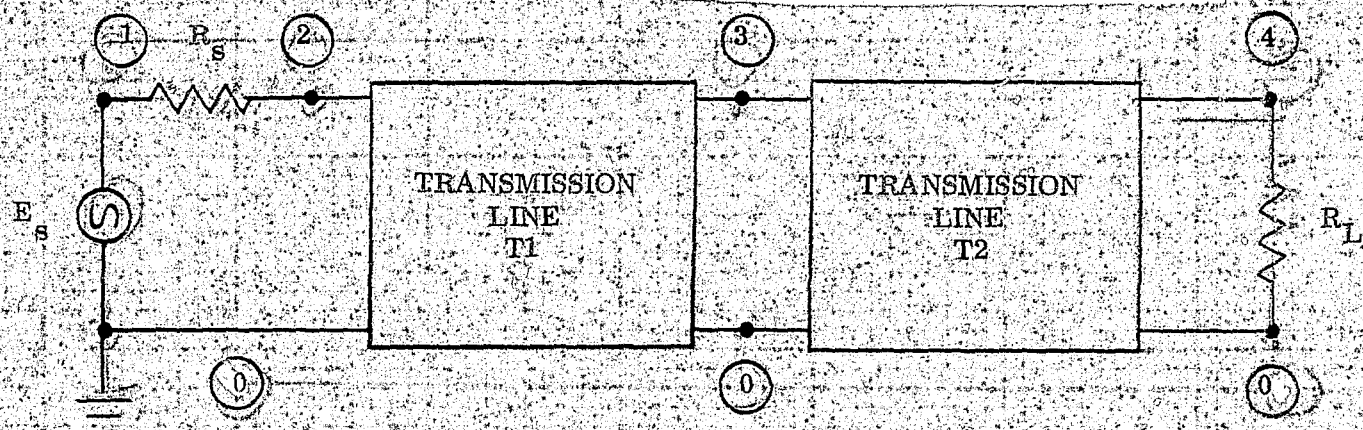

Figure 2-2. Test 1 Circuit

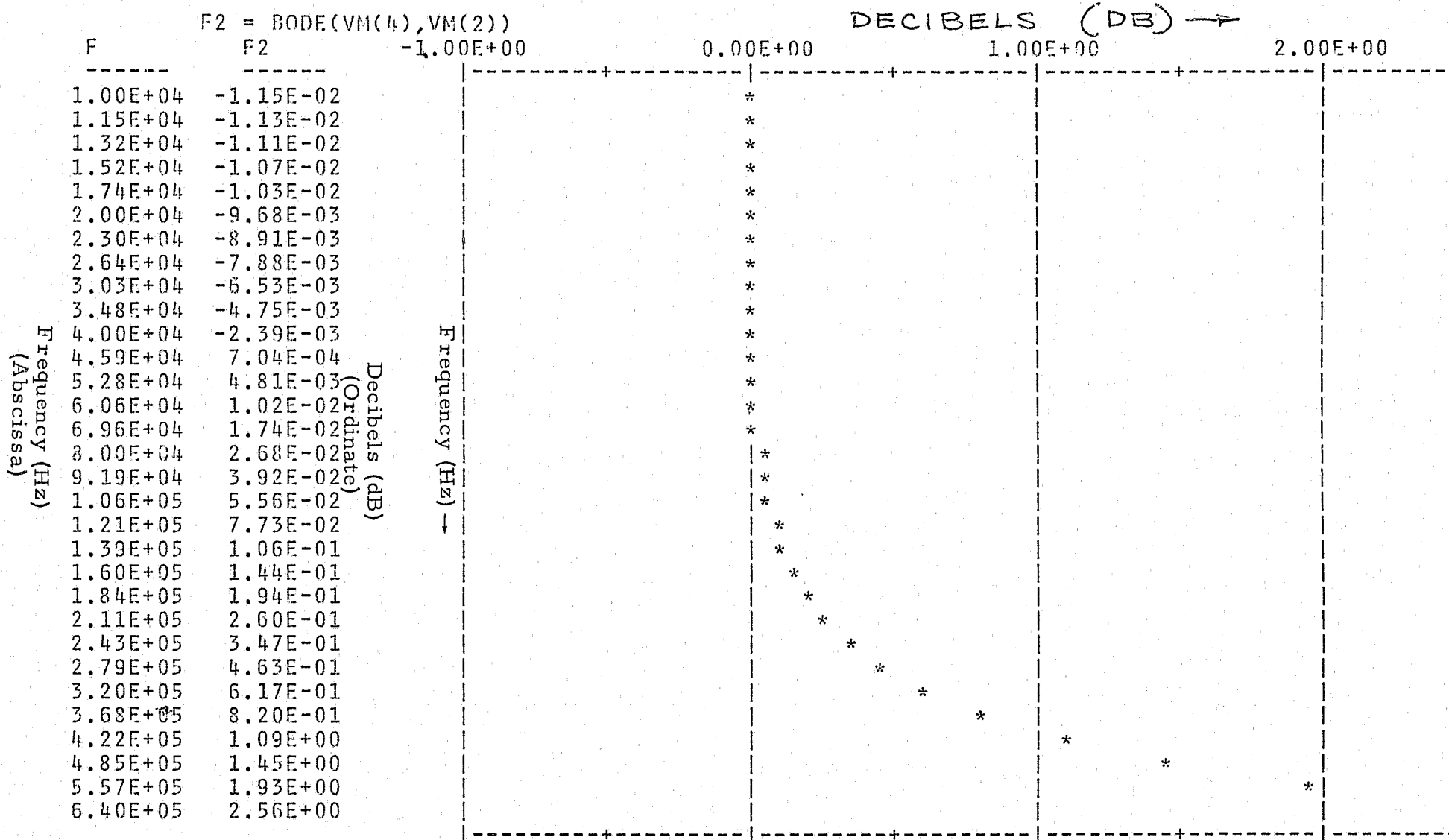

Figure 2-3. Voltage Ratio in dB Between Nodes 4,0 and 2,0 (Test 1 Circuit)

2.2.2.1 (Continued)

that could be obtained with varying termination characteristics as described in Phase I Report, pp 4-1 to 4-10. Propagation delay was calculated to be approximately 1.43 ns per foot and the loss coefficient α (where $\alpha = R/L$, $R =$ resistance per unit length, $L =$ inductance per unit length) was approximated at 10,300 inverse seconds. It must be emphasized that this loss coefficient is a parameter used by the computer model and is not the same as the classical transmission line coefficient (where $\alpha \cong R/2 \sqrt{L/C}$), which is dimensionless.

2.2.2.2 Typical Household Wiring and Loads

Computer models for household wiring were made using the previously derived transmission line models to simulate the sections of the power line. These sections were connected together to simulate the wiring of an entire house. Transmission line junctions were placed at receptacle locations and lamp sockets. This enabled us to connect various types of computer simulated loads to duplicate load changing situations during normal functioning of the household appliances.

Figure 2-5 is an example of a computer plot of voltage at the output of the receiver/control unit with SIS activated somewhere in the simulated wiring of a house. The SIS resonant frequency was set at 100 kHz and the open circuit voltage of the receiver/control unit was 1 V RMS. The curve differs from that of a normal, parasitic-free series resonant circuit because of the loading and reflection effects of the simulated power lines and loads.

The loads that were used in the simulation were also derived from the measurements taken during the Phase I Power System Characterization. However, characterization of the load so that it would be accurate over the entire frequency range of consideration involved rather complex synthesis methods. Therefore to simplify the problem loads were characterized and were accurate only for a frequency range in the vicinity of 100 kHz.

Approximately 70 computer runs were made while varying loads, wiring configurations, and SIS locations. From this, the system parameters for the PLATS design were obtained.

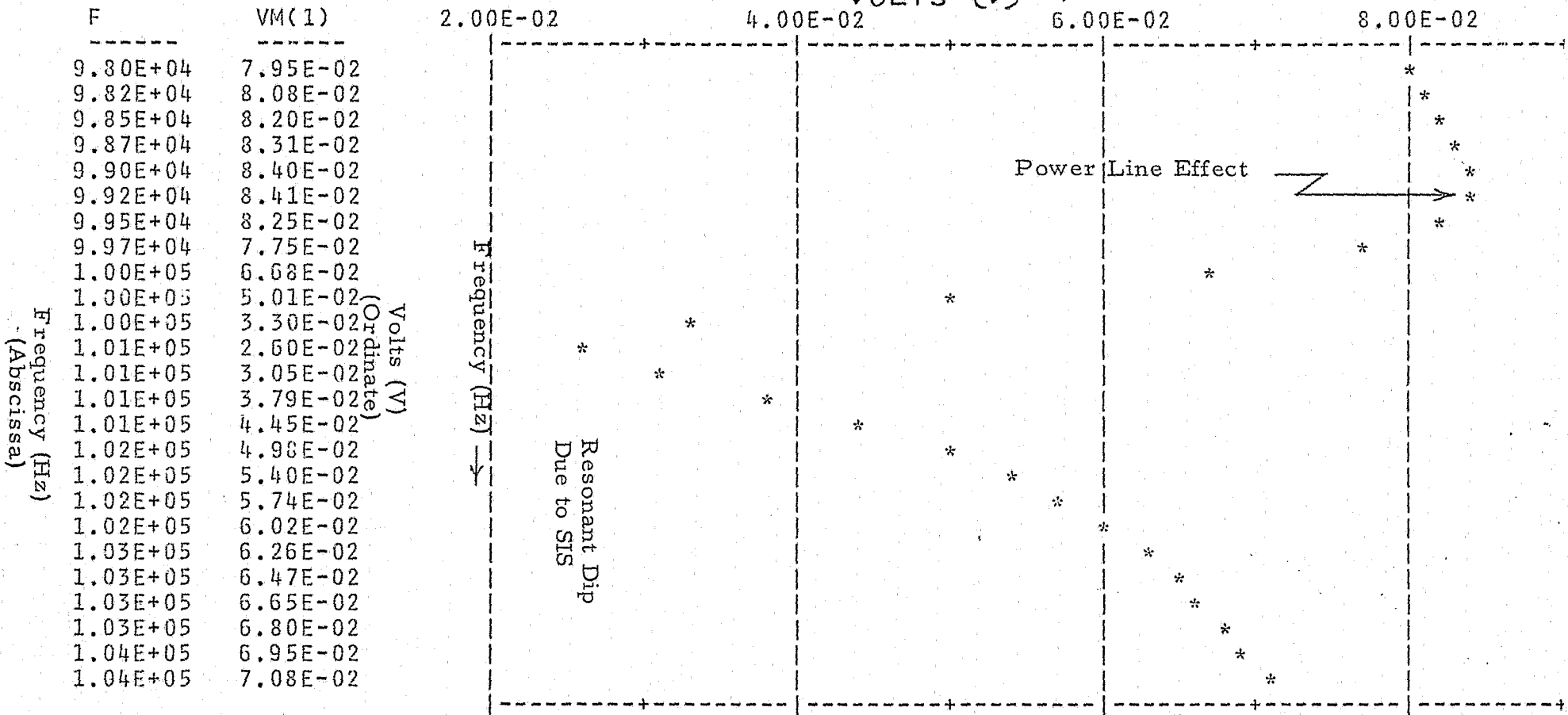

Figure 2-4. Computer Plot of Voltage Magnitude at a Specific Node for an Entire Household Wiring System Including Lamp and Heater Loads and with a SIS Connected

2.2.3 Design Parameters

The frequency range of 104 to 116 kHz was chosen as a result of a necessary compromise between several parameters. As the frequency was increased, the transmission line effects became more dominant and the operational range of the system was therefore limited. As the frequency was decreased below 100 kHz, power line noise rose very sharply and the impedance looking back into the utility distribution lines dropped. Also, as the frequency was reduced, the values and the physical size of the SIS inductor and capacitor also increased, thereby making the unit larger and more expensive.

Sweep rate choice was another compromise. The high limit on a sweep rate is set by the SIS bandwidth, that is, if the VCO is swept fast enough through the bandwidth of the SIS, an amplitude change will not be detected. Therefore, the upper sweep rate should not be any faster than 1 over the bandwidth of the SIS tuned circuit. The required post-detection bandwidth in the Receiver/Control Unit is also a function of the sweep rate. Since from the signal-to-noise standpoint it is desirable to limit the bandwidth, the sweep rate should be as low as possible. The other factor to be considered in the choice of the sweep rate is the time the SIS switch is required to be closed for the unit to register an alarm. This is an obvious limitation since at least one sweep is necessary before decision can be made that the SIS has indeed been connected across the power line.

The SIS components were chosen to give high Q at low cost and small physical size. For a given resonant frequency, the L/C ratio was an important consideration. If a low L/C ratio was chosen, the effects of the simulated external loads and power lines were significantly more pronounced and tended to distort the response even more than is shown in Figure 2-5.

For long power line runs, the distortion of the normal resonant dip increased until at lengths approximately 1/4 wavelength, an activated SIS appeared as a sharp rise in the output of the Receiver/Control Unit. This required that both increases and decreases in the output had to be detected.

2.2.3 (Continued)

The Receiver/Control Unit output impedance was chosen to be approximately 100 ohms. This value was a compromise. It is close to the median value of characteristic power line impedance. However, as the output impedance is increased, greater change in output is noted when the SIS is activated on unloaded lines, but the attenuation is increased when the line is loaded, resulting in a lower output level. Output impedances significantly lower than 100 ohms result in lessening the power line loading effects, but also reduce the change in level when an SIS is activated, increase the driver output power requirements, and make 60 Hz filtering and isolation more difficult.

There were many other trade-offs that were made in the process of deriving the system parameters. These are covered in detail in section 3.0.

3.0 DESIGN IMPLEMENTATION

3.1 BLOCK DIAGRAM

A block diagram of the Receiver/Control Unit is shown in Figure 3-1. This block diagram may be functionally subdivided into signal generation and coupling circuits, analog processing circuits, digital processing circuits, and alarm circuits. These functional subdivisions will be discussed separately below.

3.1.1 Signal Generation and Coupling Circuits

The signal generation and coupling circuits make up the top row of blocks in the block diagram. These are the circuits which generate the signal that samples the alarm status of the Shunt Impedance Switch (SIS) units. Also included are the coupling circuits which safely couple the signal to the power line.

The resonant frequency of the SIS unit was chosen to be 110 kHz. This frequency is above most of the low frequency noise present on the power line, and at the same time it is below the frequencies where power line losses are prohibitive. A frequency of exactly 100 kHz was avoided because it is a primary LORAN frequency. If we allow a $\pm 2\%$ initial tolerance on the SIS unit resonant frequency, then allow an additional $\pm 1\%$ tolerance for resonant frequency drift with temperature (400 PPM/ $^{\circ}\text{C}$, assuming a 0 to 50°C temperature range), and leave $\pm 2\%$ for transmission line distortion effects then a $\pm 5\%$ sweeping range will assure worst case coverage of the SIS resonant frequency. The sweeping oscillator was therefore chosen to sweep from 104 kHz to 116 kHz.

The frequency of the sweeping oscillator is controlled by a 1.9 Hz triangular wave oscillator. The 1.9 Hz sweeping rate was a compromise choice. It is desirable to have the sweep rate as slow as possible so that 120 Hz noise components may be filtered out without affecting the desired signal, which will be periodic at the sweep rate. However, a slower sweep rate means that a longer time is required for the system to process an alarm. The 1.9 Hz sweep rate allows 120 Hz noise to be filtered out, and the time required for the system to alarm is approximately one second.

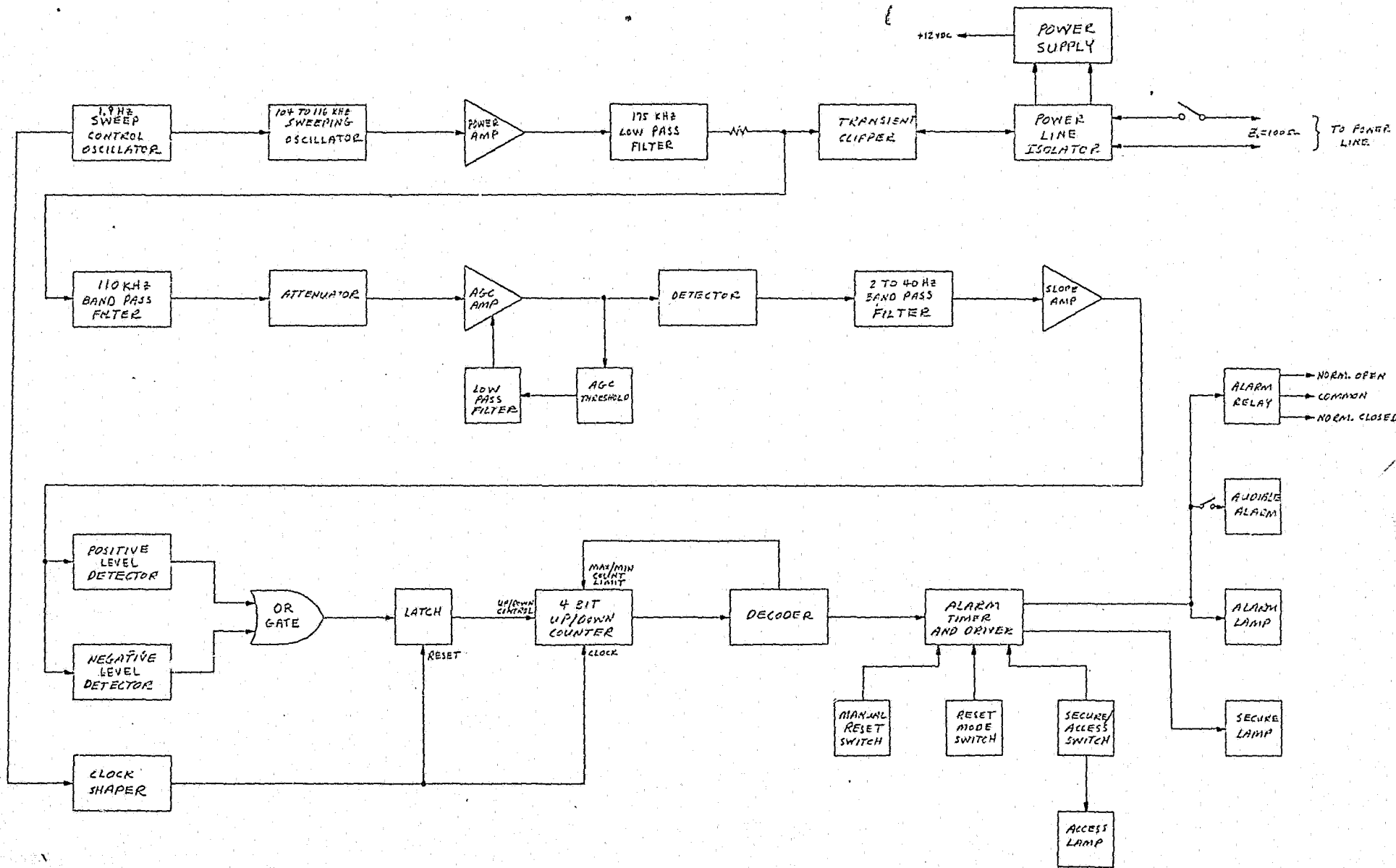

Figure 3-1. Receiver/Control Unit Block Diagram

3.1.1 (Continued)

The integrated circuit used for the sweeping oscillator has both triangular and square wave outputs. The triangular wave output is used since the harmonic content is less, and it is therefore easier to filter the triangular wave with a low pass filter to obtain a sine wave. Before being filtered, the sweeping oscillator output is amplified in a power amplifier to a level such that the signal coupled to the power line is approximately one volt RMS. The filtering is done following the amplifier so that distortion introduced by the power amplifier is also removed by the filter.

The filter is a three pole Butterworth low pass type, operating at an impedance level of 100 ohms. At 175 kHz the cutoff frequency is high enough so that the filter response is extremely flat across the 104 kHz to 116 kHz signal frequency band. (Any amplitude variation introduced by the filter in the signal band will be processed as signal and will effectively reduce the system signal to noise ratio.)

The low pass filter output is coupled to the power line through an isolation circuit. The power line isolator provides low impedance coupling at frequencies near 110 kHz and high attenuation at 60 Hz. Transformer coupling is used to reduce any possibility of shock hazard. A transient clipping circuit is included between the power line isolator and the low pass filter to prevent any large amplitude transients which may pass through the power line isolator from damaging any of the electronic circuitry.

3.1.2 Analog Processing Circuits

The analog processing circuits are the center row of blocks in Figure 3-1 plus the level detectors in the bottom row. These circuits analyze the signals on the power line in the desired band and determine whether or not the Shunt Impedance Switch (SIS) unit is present in the alarm state.

The signal at the transient clipper is effectively the same as the signal on the power line, but without the 60 Hz power frequency. This signal is used as the input to the analog processing circuits. The signal is first band pass filtered

3.1.2 (Continued)

to remove extraneous signals and noise outside the desired signal frequency band. The bandpass filter is a three pole Butterworth type with a center frequency of approximately 108 kHz. The filter center frequency is the geometric mean of the desired 3 dB passband frequencies, which are 90 kHz and 130 kHz. This somewhat wide bandwidth is required to assure flat response over the band of 104 kHz to 116 kHz while allowing for component value tolerances. The filter output is attenuated by approximately 7dB to provide the proper signal level for the AGC amplifier input and prevent overloading of the input stages prior to the AGC stage.

The AGC amplifier has a gain of between 0 dB and 50 dB depending on the signal amplitude. The purpose of the AGC amplifier is to compensate for varying loads on the power line over time intervals greater than one sweep time. The power line impedance, and therefore the signal amplitude, will change every time a 60 Hz load is switched on or off. The AGC amplifier keeps the average signal amplitude going into the detector constant. This eliminates dynamic range problems since it is the dynamic variation in signal amplitude during each sweep which determines whether or not the SIS unit is in the alarm state.

The AGC threshold sets the level at which the AGC action occurs and thereby the output level of the AGC amplifier. The low pass filter in the AGC control loop determines the response time of the AGC amplifier. It is desired that the AGC amplifier respond as quickly as possible to a step change in signal amplitude, but not so quickly that it acts during the time required to sweep through an alarm SIS unit. If the AGC response is too fast, the result will be an effective decrease in signal-to-noise ratio. The optimum filter response was determined to be approximately 0.36 Hz, and the filter is a single pole RC type.

The AGC amplifier output is applied to an envelope detector which extracts the signal pulse caused by the presence of an alarmed SIS unit on the power line. If the SIS unit is not in the alarm state, the detector output is a DC voltage. The detector output is post-detection filtered by a bandpass filter with a bandwidth of 2 Hz to 40 Hz. This bandwidth was chosen as narrow as possible without seriously degrading the shape or amplitude of the alarm signal pulse from the detector.

3.1.2 (Continued)

The post-detection filter was included to solve two specific problems. First, the impedance of the power line is frequency dependent and results in a small degree of variation in the signal amplitude across the 104 kHz to 116 kHz frequency band under no-alarm conditions. This amplitude variation is undesirable as it reduces the signal-to-noise ratio and increases the probability of a false alarm. This is removed by the high pass section of the post-detection filter.

The second reason for including post-detection filtering is that certain power line loads, notably "transformerless" radios and television sets, modulate the power line impedance at a 120 Hz rate. This is a severe problem since the power line impedance modulation is very similar to an actual alarm signal except that it occurs at a 120 Hz rate instead of at 3.8 Hz rate. Thus a post-detection low pass filter section with a corner frequency at 40 Hz removes most of the 120 Hz noise but has little effect on the signal pulses. The low pass filter section combined with the high pass section form the complete 2 Hz to 40 Hz post-detection bandpass filter.

In order for the system to have sufficient range to cover a typical residence, additional gain is required following the post-detection filter. This gain is provided in the form of a slope amplifier. A slope amplifier is a high-pass, or differentiating amplifier whose output is a function of the magnitude of the slope of the input signal. This type of amplifier was chosen to increase rejection of low frequency effects such as change in amplitude during sweep.

To take full advantage of the slope amplifier output, two level detectors are required. The slope amplifier drives both a positive level detector and a negative level detector. These level detectors are identical except for the reference level, and provide the thresholds which must be crossed for the Receiver/Control Unit to determine that the SIS unit is in the alarm state. The level detector outputs are binary logic levels with zero volts indicating signal below threshold (no-alarm) and 12 volts indicating signal over threshold (alarm).

3.1.3 Digital Processing Circuits

The digital processing circuits set additional requirements which must be met before the Receiver/Control Unit will sound an alarm. This is done to reduce false alarms to a minimum while retaining full ability to respond to a legitimate alarm. The digital processing circuits actually implement the digital equivalent of an analog integrator. The digital approach is extremely flexible and accurate and provides improved performance over analog integrators when long integration times are required.

The master clock controlling the digital circuits is derived from the 1.9 Hz sweep control oscillator. A clock shaper circuit generates a narrow clock pulse each time the sweep control oscillator triangular wave changes slope, or in other words, each time the sweeping oscillator changes the direction of sweep. The clock pulses occur at a 3.8 Hz rate and synchronize the digital circuits with the sweep rate of the sweeping oscillator.

The outputs of the two level detectors are combined in an OR gate, which in turn sets a latching flip-flop. The latch remembers, until it is reset by the next clock pulse, when a threshold crossing has occurred. The latch also controls the counting direction of an up/down counter. If no threshold crossing occurs during the interval between two clock pulses, the second clock pulse will cause the counter to count down. If a threshold crossing does occur, the counter will count up. Decoding and limiting is provided so that the counter cannot count down past zero nor up past four. When zero is reached in the down count direction, the counter stops counting and holds a count of zero until commanded to count up. When four is reached in the up count direction, the counter stops counting and holds a count of four until commanded to count down. Also, when the counter reaches four, the decoder triggers the alarm driver circuits.

3.1.4 Alarm Circuits

The alarm circuits include the alarm timer and driver, the alarm lamp and tone generator, and all the front panel controls and indicators except the power switch. The alarm timer operates as a latch when the system is in the manual reset mode and will hold an alarm until the manual reset button is pressed. In the auto reset mode, the alarm timer functions as a retriggerable one shot with a period of approximately three seconds. In either mode the alarm timer will cause an alarm to sound as long as the up/down counter holds a count of four. If the manual reset button is depressed while the counter maintains a count of four, the alarm will be silenced only as long as the reset button is held depressed, regardless of whether the mode switch is in the auto or manual reset position. The secure/access switch forces the logic into the no-alarm state and allows the up/down counter to count down to zero, regardless of the alarm status of any SIS unit connected to the system.

3.2 CIRCUIT DESCRIPTION

A schematic diagram of the Receiver/Control Unit, is shown in Figures 3-2 and 3-3 and a parts list is included at the end of the chapter. The following circuit description will relate portions of the schematic to the corresponding functional block discussed above in Section 3.1.

3.2.1 Signal Generation and Coupling Circuits

The 1.9 Hz sweep control oscillator consists of integrated circuit U1 and the associated timing components. U1 is a Signetics NE566V function generator integrated circuit which has both triangular wave and square wave outputs. The triangular wave output is used to frequency modulate the sweeping oscillator, and the square wave output is used to generate the clock pulses which control the digital processing circuitry. The 1.9 Hz frequency is determined by resistor R4 and capacitor C3. A DC bias is applied to the modulation input and is variable by means of trimmer R2 in order to allow exact adjustment of the frequency. The triangular output is attenuated by R5, R6, and R7 to the proper level required to modulate the sweeping oscillator U2 over the desired 104 kHz to 116 kHz frequency band.

U2 is also an NE566V integrated circuit and performs the sweeping oscillator function. The center frequency is set by R11, C8, and C9, and fine center frequency adjustments are made with R9. The triangle wave output is used to drive the power amplifier, and the square wave output is not used.

The power amplifier, U3, is a Motorola MC1454G integrated circuit. This device is capable of one watt output at frequencies up to 300 kHz. In this application, however, actual power output is approximately 0.2 watts, and no heat sink is required. The triangle wave output of the power amplifier is filtered by a 175 kHz low pass filter to give a sine wave output of approximately 2.3 volts rms. The filter is a three pole Butterworth type, and consists of C15, L₁, L₂, and C16.

The transient clipping circuit consists of two 6.2 volt zener diodes connected back-to-back in series with a current limiting resistor. The power line isolation circuit consists of T1 and C18. T1 is designed to pass frequencies around 110 kHz and block the 60 Hz power frequency. C18 prevents large 60 Hz currents from flowing through the secondary of T1.

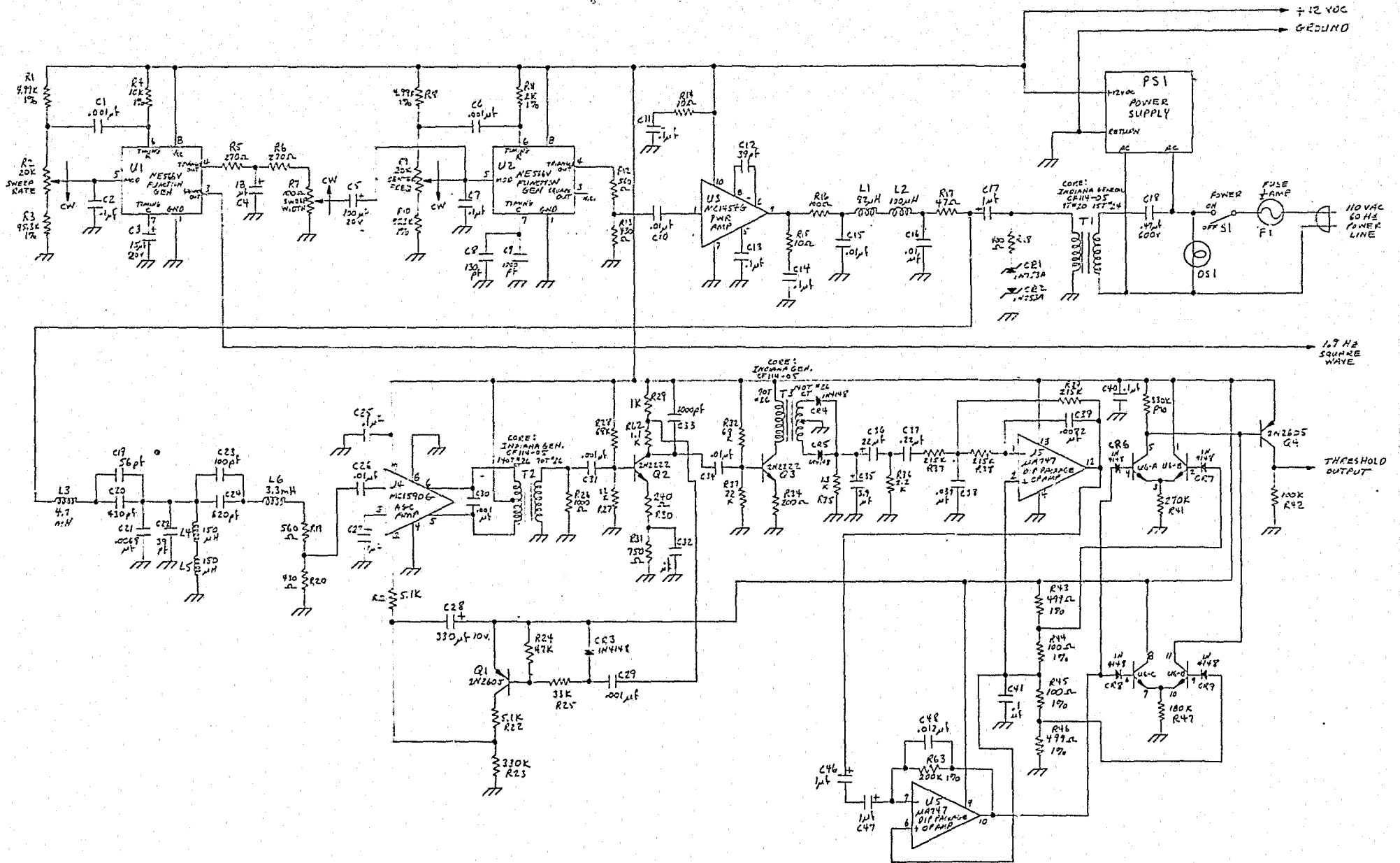

Figure 3-2. Receiver/Control Unit Schematic (Sheet 1 of 2)

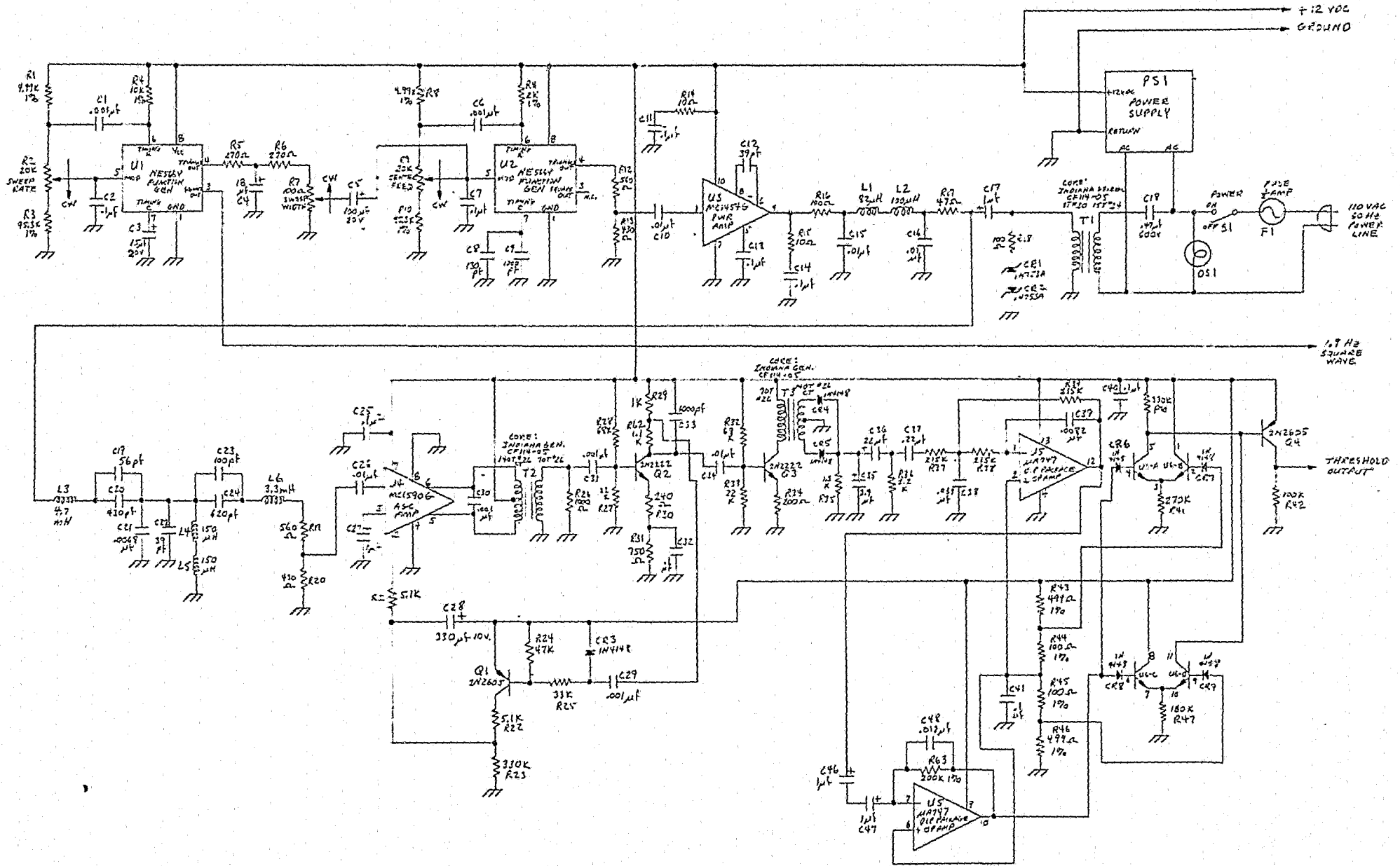

Figure 3-2. Receiver/Control Unit Schematic (Sheet 1 of 2)

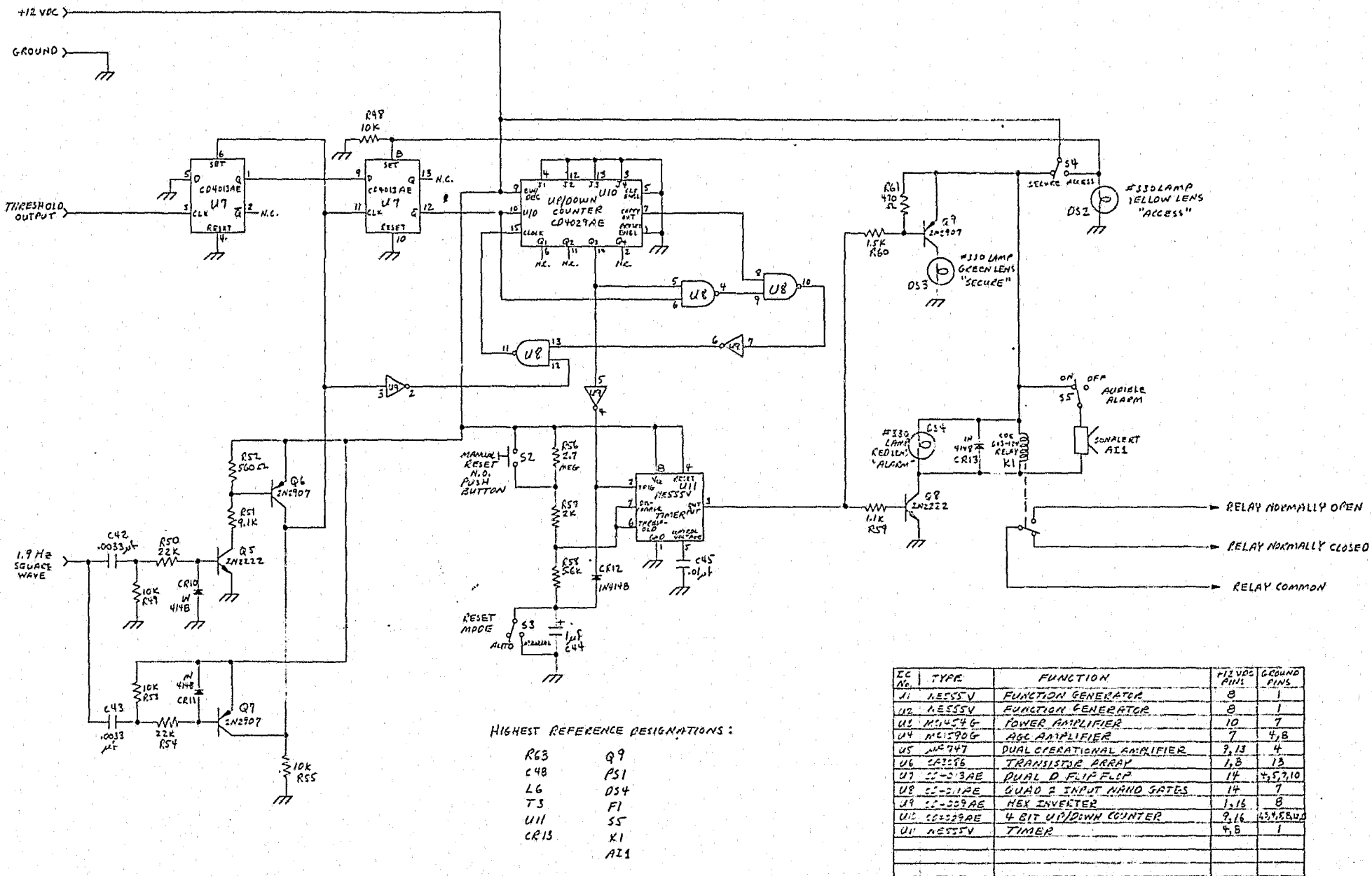

Figure 3-3. Receiver/Control Unit Schematic (Sheet 2 of 2)

3.2.2 Analog Processing Circuits

The 110 kHz band pass filter is a three pole Butterworth type consisting of L3 through L6 and C19 through C24. The filter output is attenuated approximately 7 dB by R19 and R20. The AGC amplifier consists of U4 and Q2, the AGC threshold is provided by Q1, and the AGC low pass filter consists of C28 and the net equivalent parallel resistance across C28. The Motorola MC1590G used for U4 is a wide band amplifier with differential inputs and outputs and built in AGC. The differential output capability is used by differentially driving T2 in order to gain rejection of noise on the power supply line.

The detector is a transformer coupled (T3) full wave rectifier driven by common emitter amplifier Q3. Although this circuit has an additional 3 dB processing gain over the simpler half wave rectifier, the main reason for using the transformer coupled full wave rectifier is that it provides nearly equal charging and discharging time constants to the post-detector filter. In other words, the loaded output impedance of the detector circuit is the same when one of the rectifying diodes is in conduction as it is when both diodes are reverse biased. This characteristic aids post-detection filtering of unwanted noise.

The 2 to 40 Hz band pass filter is actually a 2 Hz high pass filter followed by a 40 Hz low pass filter. The 2 Hz high pass filter is a two stage RC filter consisting of C36, R36, C37, and R37. The two poles of this filter are far enough apart that interaction is negligible. The 40 Hz low pass filter is an active filter using one half of U5, which is a dual operational amplifier. The circuit is a two pole type, and the element values for R37 through R39 and C38 and C39 were chosen to give a Butterworth response.

The slope amplifier uses the second half of U5 and is a conventional differentiating amplifier circuit. The output voltage of this circuit is equal to the input current multiplied by the feedback impedance.

The two level detectors are identical except for the reference voltage. A transistor array consisting of five transistors on the same chip is used to make two simple differential amplifier circuits. This insures that the four transistors will have similar characteristics and further circuit sophistication is not required. The two reference voltages as well as a "virtual ground" reference voltage for the two operational amplifiers are obtained from a single voltage divider chain, R43 through R46. If all of the resistors in the divider have the same temperature coefficient, resistance changes with temperature will cancel and will have no net result in the circuit.

3.2.3 Digital Processing Circuits

The digital clock is derived from the square wave output of the 1.9 Hz sweep control oscillator. The positive going edge of the square wave is differentiated by C42 and R49, then inverted twice by transistor switches Q5 and Q6. The negative going edge is likewise differentiated by C43 and R53, but is only inverted once by Q7. The collectors of Q6 and Q7 share a common load resistor, R55, which performs a logical OR function. The result is a narrow positive going clock pulse at each transition of the 1.9 Hz square wave.

The OR function combining the outputs of the two level detectors is performed by connecting the two output collectors of the two differential amplifiers to a common load resistor, R40. Q4 is a saturating switch which turns on whenever either threshold is crossed.

The remainder of the logic circuits were discussed in detail above in section 3.1.3. COS/MOS integrated circuits are used because their supply voltage requirements are compatible with the 12 volts DC used by the analog circuits. Thus only one inexpensive power supply is required.

3.2.4 Alarm Circuits

Most of the alarm circuit functions are performed by U11, a Signetics NE555V timer integrated circuit. When S3 is in the auto reset position, the NE555V functions as a one shot multivibrator which is triggered when U9 pin 4 goes to the low state. However, diode CR12 prevents the timing capacitor C44 from charging until the up/down counter begins counting down and U9 pin 4 goes to the high state. When S3 is in the manual reset position, C44 can never charge and the NE555V acts as a latch. Manual resetting is accomplished by shorting out a large part of the timing resistance, thereby exceeding the threshold internal to the NE555V and allowing it to reset. However, if the trigger input to the timer is still "low", a new cycle will begin immediately when the manual reset button is released.

Q8 and Q9 are saturating switches which provide the necessary drive to light the alarm or secure lamp, respectively. Note that Q8 and Q9 are complementary transistors driven from the same source so that the alarm lamp and secure lamp can never be lighted at the same time.

3.3 SHUNT IMPEDANCE SWITCH

A schematic diagram of the Shunt Impedance Switch (SIS) is shown in Figure 3-4. The SIS is a series tuned circuit having a resonant frequency which is switchable between

T1:
 Core: Indiana General CF108-06
 Primary: 25 Turns # 24 Wire
 Secondary: 25 Turns # 24 Wire
 Bifilar Wound

L1:
 Core: Micrometals T106-15
 185 Turns #24 Wire

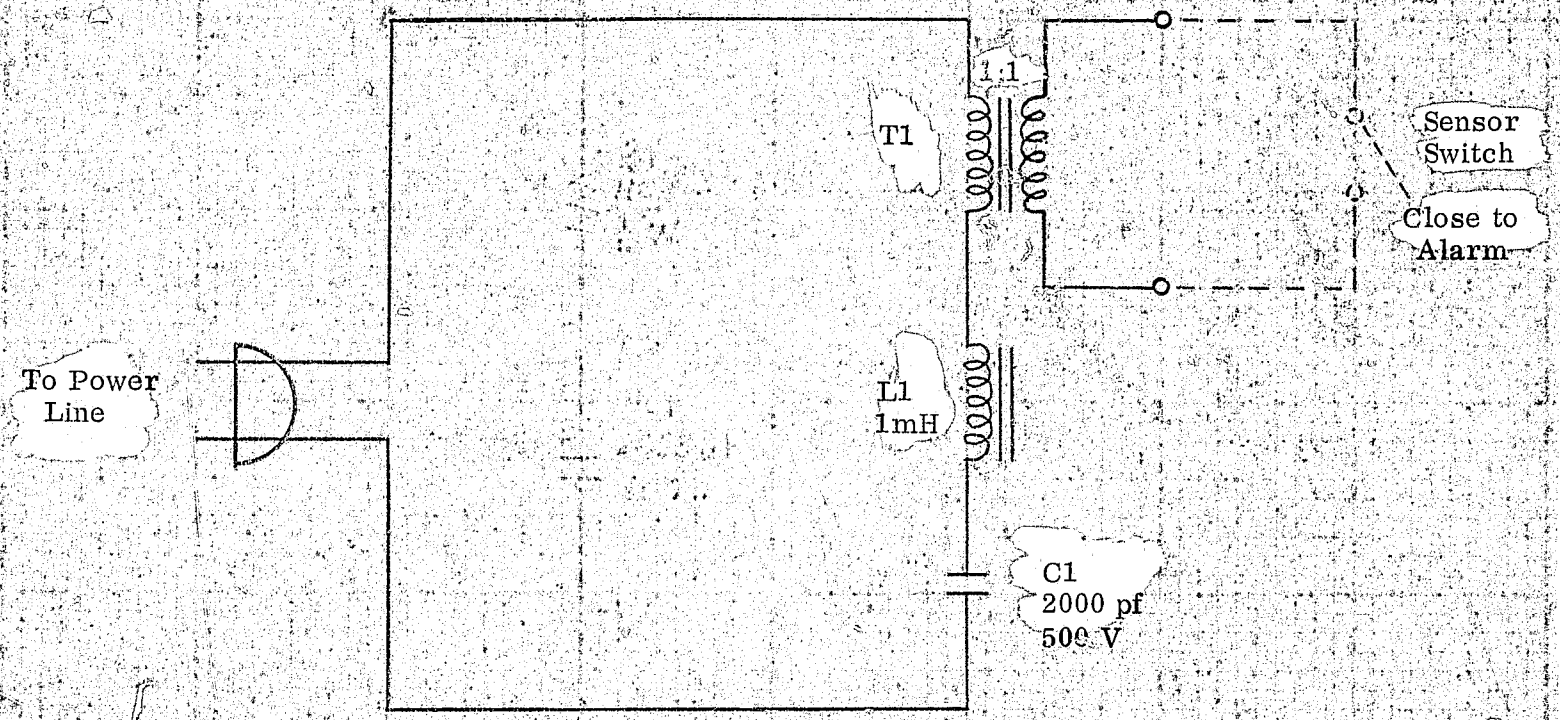

Figure 3-4. SIS Schematic

Figure 3.4: SIS Schematic

3.3 (Continued)

two values by means of an external switch. In an operating PLATS system, the external switch is provided by the intrusion sensor. When the external effective inductance of the tuned circuit is L1 in series with the inductance of the primary winding of T1, the resulting resonant frequency is below 90 kHz, and the circuit impedance between 104 kHz and 116 kHz is much higher than the normal power line impedance. When the intrusion sensor switch closes, the secondary of T1 is short circuited. T1 is a very tightly coupled transformer with a 1:1 turns ratio, and the short circuit is effectively reflected across the primary winding. The resulting tuned circuit is then merely L1 in series with C1, and the resonant frequency changes to 110 kHz, where it is detected by the Receiver/Control Unit. The resonant circuit Q is approximately 120-140.

Capacitor C1, in addition to being a component in the tuned circuit, blocks 60 Hz power currents from flowing through the primary of T1. T1 is designed to have poor coupling at 60 Hz, so that the small 60 Hz current which does pass through C1 (approximately 90 microamperes) induces a minimum of voltage across the secondary. Thus the external sensor switch input terminals are isolated from the power line and the possible shock hazard is eliminated.

SYLVANIA ELECTRONIC SYSTEMS
DIVISION OF SYLVANIA ELECTRIC PRODUCTS INC.
MOUNTAIN VIEW, CALIF

PL

CODE IDENT 07397

SHEET 1 OF 11

REV

PREP R.H. Bell DATE 9/24/73
CHK
APPD
APPD

PLATS
RECEIVER/CONTROL UNIT
PARTS LIST

QUANTITY REQUIRED				KEY	CODE IDENT	PART OR IDENTIFYING NO.	SYLVANIA PART NO.	NOMENCLATURE OR DESCRIPTION	SYL REF	NOTE	ITEM NO.
		-1									
		2		R1	RN5504991F		RESISTOR, 4.99K ± 1%, 1/8W				
		2		R2	3006P-1-203	BOURNS	VARIABLE, 20K				
		2		R3	RN5509532F		95.3K ± 1%, 1/8W				
		1		R4	RN5501002F		10.0K ± 1%, 1/8W				
		2		R5	RC07GF271J		270Ω ± 5%, 1/4W				
		-		R6	RC07GF271J		270Ω ± 5%, 1/4W				
		1		R7	3006P-1-101	BOURNS	VARIABLE, 100Ω				
		-		R8	RN5504991F		4.99K ± 1%, 1/8W				
		-		R9	3006P-1-203	BOURNS	VARIABLE, 20K				
		-		R10	RN5509532F		95.3K ± 1%, 1/8W				
		1		R11	RN5502001F		2.00K ± 1%, 1/8W				
		3		R12	RC07GF561J		RESISTOR, 560Ω ± 5%, 1/4W				

SYM	REVISION DESCRIPTION	DATE	APPROVED	SYM	REVISION DESCRIPTION	DATE	APPROVED

KEY:
* - VENDOR ITEM - FOR PROCUREMENT OR PART NUMBER SEE SPECIFICATION CONTROL OR SOURCE CONTROL DRAWING.
F - FEET
I - INCHES

NOTES:

MODEL

PL

NOTES:

PLATS

QUANTITY REQUIRED				KEY	CODE IDENT	PART OR IDENTIFYING NO.	GTE SYLVANIA PART NO.	NOMENCLATURE OR DESCRIPTION	NOTE	ITEM NO.
			-1							
			2		R13	RC07GF431J		RESISTOR, 430Ω ± 5%, 1/4 W		
			2		R14	RC07GF100J		, 10Ω		
			-		R15	RC07GF100J		, 10Ω		
			2		R16	RC07GF101J		, 100Ω		
			1		R17	RC07GF470J		, 47Ω		
			-		R18	RC07GF101J		, 100Ω		
			-		R19	RC07GF561J		, 560Ω		
			-		R20	RC07GF431J		, 430Ω		
			2		R21	RC07GF512J		, 5.1K		
			-		R22	RC07GF512J		, 5.1K		
			2		R23	RC07GF334J		, 330K		
			1		R24	RC07GF473J		, 47K		
			1		R25	RC07GF333J		, 33K		
			2		R26	RC07GF102J		, 1K		
			4		R27	RC07GF223J		, 22K		
			2		R28	RC07GF683J		, 68K		
			-		R29	RC07GF102J		, 1K		
			1		R30	RC07GF241J		, 240Ω		
			1		R31	RC07GF751J		, 750Ω		
			-		R32	RC07GF683J		, 68K		
			-		R33	RC07GF223J		, 22K		
			1		R34	RC07GF201J		RESISTOR, 200Ω ± 5%, 1/4 W		

KEY:

*-VENDOR ITEM - FOR PROCUREMENT OR PART NUMBER SEE SPECIFICATION CONTROL OR SOURCE CONTROL DRAWING

F- FEET
I- INCHES

B- BULK
A/R- AS REQUIRED
R- REFERENCE

PL

CODE IDENT 07397

SHEET 2 OF 11

REV

3-15

NOTES:

PLATS

QUANTITY REQUIRED				KEY	CODE IDENT	PART OR IDENTIFYING NO.	GTE SYLVANIA PART NO.	NOMENCLATURE OR DESCRIPTION	NOTE	ITEM NO.
			-/							
			1		R35	RC07GF132J		RESISTOR, 1.3K \pm 5%, 1/4W		
			1		R36	RC07GF222J		, 2.2K \pm 5%, 1/4W		
			3		R37	RN5502153F		, 215K \pm 1%, 1/8W		
			—		R38	RN5502153F		, 215K \pm 1%, 1/8W		
			—		R39	RN5502153F		, 215K \pm 1%, 1/8W		
			—		R40	RC07GF334J		, 330K \pm 5%, 1/4W		
			1		R41	RC07GF274J		, 270K \pm 5%, 1/4W		
			1		R42	RC07GF104J		, 100K \pm 5%, 1/4W		
			2		R43	RN5504990F		, 499 Ω \pm 1%, 1/8W		
			2		R44	RN5501000F		, 100 Ω \pm 1%, 1/8W		
			—		R45	RN5501000F		, 100 Ω \pm 1%, 1/8W		
			—		R46	RN5504990F		, 499 Ω \pm 1%, 1/8W		
			1		R47	RC07GF184J		, 180K \pm 5%, 1/4W		
			4		R48	RC07GF103J		, 10K		
			—		R49	RC07GF103J		, 10K		
			—		R50	RC07GF223J		, 22K		
			1		R51	RC07GF912J		, 9.1K		
			—		R52	RC07GF561J		, 560 Ω		
			—		R53	RC07GF103J		, 10K		
			—		R54	RC07GF223J		, 22K		
			—		R55	RC07GF103J		, 10K		
			1		R56	RC07GF275J		RESISTOR, 2.7M \pm 5%, 1/4W		

KEY:

*-VENDOR ITEM - FOR PROCUREMENT OR PART NUMBER SEE SPECIFICATION CONTROL OR SOURCE CONTROL DRAWING

F- FEET
I- INCHES

B- BULK
A/R- AS REQUIRED
R- REFERENCE

PL

CODE IDENT 07397

SHEET 3 OF 11

REV

NOTES:

PLATS

QUANTITY REQUIRED				KEY	CODE IDENT	PART OR IDENTIFYING NO.	GTE SYLVANIA PART NO.	NOMENCLATURE OR DESCRIPTION	NOTE	ITEM NO.
			-1		R57	RC07GF202J		RESISTOR, 2K \pm 5%, 1/4 W		
			1		R58	RC07GF562J		↑ , 5.6K ↓		
			2		R59	RC07GF112J		, 1.1K		
			1		R60	RC07GF152J		, 1.5K		
			1		R61	RC07GF471J		, 470 Ω		
			-		R62	RC07GF112J		↓ , 1.1K \pm 5%, 1/4 W		
			1		R63	RN55D2003 F		RESISTOR, 200K \pm 1%, 1/8 W		
			5		C1	CK05BX102K		CAPACITOR, CERAMIC, 0.001 μ f		
			9		C2	CK06BX104K		↓ , CERAMIC, 0.1 μ f		
			1		C3	CSR13E156KL		↓ , TANTALUM, 15 μ f 20VDC		
			1		C4	CSR13D186KL		↓ , TANTALUM, 18 μ f 15VDC		
			1		C5	CSR13E107KL		CAPACITOR, TANTALUM, 100 μ f 20VDC		

KEY:

*-VENDOR ITEM - FOR PROCUREMENT OR PART NUMBER SEE SPECIFICATION CONTROL OR SOURCE CONTROL DRAWING

F- FEET
I- INCHES

B- BULK
A/R- AS REQUIRED
R- REFERENCE

PL

CODE IDENT 07397

SHEET 4 OF 11

REV

NOTES:

PLATS

QUANTITY REQUIRED				KEY	CODE IDENT	PART OR IDENTIFYING NO.	GTE SYLVANIA PART NO.	NOMENCLATURE OR DESCRIPTION	NOTE	ITEM NO.
			-1		C6	CK05BX102K		CAPACITOR, CERAMIC, 0.001 μ f		
			-		C7	CK06BX104K		, CERAMIC, 0.1 μ f		
			1		C8	CM05FD131J03		, MICA, 130 pf		
			2		C9	CM19FD102J03		, MICA, 1000 pf		
			4		C10	CK06BX103K		, CERAMIC, 0.01 μ f		
			-		C11	CK06BX104K		, CERAMIC, 0.1 μ f		
			2		C12	CM05FD390J03		, MICA, 39 pf		
			-		C13	CK06BX104K		, CERAMIC, 0.1 μ f		
			-		C14	CK06BX104K		, CERAMIC, 0.1 μ f		
			2		C15	19-1039R8	SPRAGUE	, FILM, 0.01 μ f		
			-		C16	192P1039R8	SPRAGUE	, FILM, 0.01 μ f		
			5		C17	CSR13G105KL		, TANTALUM, 1 μ f 50 VDC		
			1		C18	MPY-6P47	CDE	, PAPER, 0.47 μ f 600 VDC		
			1		C19	CM05FD560J03		, MICA, 56 pf		
			1		C20	CM05FD431J03		, MICA, 430 pf		
			1		C21	192P6829R8	SPRAGUE	, FILM, 0.0068 μ f		
			-		C22	CM05FD390J03		, MICA, 39 pf		
			1		C23	CM05FD101J03		, MICA, 100 pf		
			1		C24	CM06FD621J03		, MICA, 620 pf		
			-		C25	CK06BX104K		, CERAMIC, 0.1 μ f		
			-		C26	CK06BX103K		, CERAMIC, 0.01 μ f		
			-		C27	CSR13G105KL		CAPACITOR, TANTALUM, 1 μ f 50 VDC		

KEY:

*-VENDOR ITEM - FOR PROCUREMENT OR PART NUMBER SEE SPECIFICATION CONTROL OR SOURCE CONTROL DRAWING

F- FEET
I- INCHES

B- BULK
A/R- AS REQUIRED
R- REFERENCE //

PL

CODE IDENT 07397

SHEET 5 OF 11

REV

NOTES:

PLATS

QUANTITY REQUIRED				KEY	CODE IDENT	PART OR IDENTIFYING NO.	GTE SYLVANIA PART NO.	NOMENCLATURE OR DESCRIPTION	NOTE	ITEM NO.
			-1							
			1		C28	MTP337M101PIC	MALLORY	CAPACITOR, TANTALUM, 330 μ F 10VDC		
			-		C29	CK05BX102K		, CERAMIC, 0.001 μ F		
			-		C30	CK05BX102K		, CERAMIC, 0.001 μ F		
			-		C31	CK05BX102K		, CERAMIC, 0.001 μ F		
			-		C32	CK06BX104K		, CERAMIC, 0.1 μ F		
			-		C33	CM19FD102J03		, MICA, 1000 pF		
			-		C34	CK06BX103K		, CERAMIC, 0.01 μ F		
			1		C35	CSR13G395KL		, TANTALUM, 3.9 μ F 50VDC		
			1		C36	CSR13D226KL		, TANTALUM, 22 μ F 15VDC		
			1		C37	192P2249R8	SPRAGUE	, FILM, 0.22 μ F		
			1		C38	192P3939R8	SPRAGUE	, FILM, 0.039 μ F		
			1		C39	192P8229R8	SPRAGUE	, FILM, 0.0082 μ F		
			-		C40	CK06BX104K		, CERAMIC, 0.1 μ F		
			-		C41	CK06BX104K		, CERAMIC, 0.1 μ F		
			2		C42	192P3329R8	SPRAGUE	, FILM, 0.0033 μ F		
			-		C43	192P3329R8	SPRAGUE	, FILM, 0.0033 μ F		
			-		C44	CSR13G105KL		, TANTALUM, 1 μ F 50VDC		
			-		C45	CK06BX103K		, CERAMIC, 0.01 μ F		
			-		C46	CSR13G105KL		, TANTALUM, 1 μ F 50VDC		
			-		C47	CSR13G105KL		, TANTALUM, 1 μ F 50VDC		
			1		C48	192P1239R8	SPRAGUE	CAPACITOR, FILM, 0.012 μ F		

KEY:

*-VENDOR ITEM - FOR PROCUREMENT OR PART NUMBER SEE SPECIFICATION CONTROL OR SOURCE CONTROL DRAWING

F- FEET
I- INCHES

B- BULK
A/R- AS REQUIRED
R- REFERENCE

PL

CODE IDENT 07397

SHEET 6 OF 11

REV

NOTES:

PLATS

QUANTITY REQUIRED				KEY	CODE IDENT	PART OR IDENTIFYING NO.	GTE SYLVANIA PART NO.	NOMENCLATURE OR DESCRIPTION	NOTE	ITEM NO.
			-1							
			1		L1	MS90537-36		COIL, 82 μ H		
			1		L2	MS90537-37		↑, 100 μ H		
			1		L3	MS90537-57		, 4.7mH		
			2		L4	MS90537-39		, 150 μ H		
			-		L5	MS90537-39		↓, 150 μ H		
			1		L6	MS90537-55		COIL, 3.3 mH		
			3		T1	CF114-05	INDIANA GENERAL	CORE, TOROID		
			-		T2	CF114-05	INDIANA GENERAL	CORE, TOROID		
			-		T3	CF114-05	INDIANA GENERAL	CORE, TOROID		

KEY:

*-VENDOR ITEM - FOR PROCUREMENT OR PART NUMBER SEE SPECIFICATION CONTROL OR SOURCE CONTROL DRAWING

F- FEET
I- INCHES

B- BULK
A/R- AS REQUIRED
R- REFERENCE

PL

CODE IDENT 07397

SHEET 7 OF 11

REV

NOTES:

PLATS

QUANTITY REQUIRED				KEY	CODE IDENT	PART OR IDENTIFYING NO.	GTE SYLVANIA PART NO.	NOMENCLATURE OR DESCRIPTION	NOTE	ITEM NO.
			-1							
			2		U1	NE566V	SIGNETICS	INTEGRATED CIRCUIT, FUNCTION GEN.		
			-		U2	NE566V	SIGNETICS	, FUNCTION GEN.		
			1		U3	MC1454G	MOTOROLA	, POWER AMPL.		
			1		U4	MC1590G	MOTOROLA	, AGC AMPL.		
			1		U5	U7A7747393	FAIRCHILD	, A747 OP. AMP.		
			1		U6	CA3086	RCA	, TRANSISTOR ARRAY		
			1		U7	CD4013AE	RCA	, DUAL D FLIP-FLOP		
			1		U8	CD4011AE	RCA	, NAND GATES		
			1		U9	CD4009AE	RCA	, HEX INVERTERS		
			1		U10	CD4029AE	RCA	, UP/DOWN COUNTER		
			1		U11	NE555V	SIGNETICS	INTEGRATED CIRCUIT, TIMER		
			2		CR1	1N753A		DIODE, ZENER, 6.2V		
			-		CR2	1N753A		DIODE, ZENER, 6.2V		
			11		CR3	1N4148		DIODE		
			-		CR4	1N4148				
			-		CR5	1N4148				
			-		CR6	1N4148				
			-		CR7	1N4148				
			-		CR8	1N4148		DIODE		

KEY:

*-VENDOR ITEM - FOR PROCUREMENT OR PART NUMBER SEE SPECIFICATION CONTROL OR SOURCE CONTROL DRAWING

F- FEET
I- INCHES

B- BULK
A/R- AS REQUIRED
R- REFERENCE

PL

CODE IDENT 07397

SHEET 8 OF 11

REV

NOTES:

PLATS

QUANTITY REQUIRED				KEY	CODE IDENT	PART OR IDENTIFYING NO.	GTE SYLVANIA PART NO.	NOMENCLATURE OR DESCRIPTION	NOTE	ITEM NO.
			-1		CR9	1N4148		DIODE		
			-		CR10	1N4148		↓		
			-		CR11	1N4148		↓		
			-		CR12	1N4148		↓		
			-		CR13	1N4148		DIODE		
			2		Q1	2N2605		TRANSISTOR		
			4		Q2	2N2222		↑		
			-		Q3	2N2222		↑		
			-		Q4	2N2605		↑		
			-		Q5	2N2222		↑		
			3		Q6	2N2907		↑		
			-		Q7	2N2907		↑		
			-		Q8	2N2222		↑		
			-		Q9	2N2907		TRANSISTOR		

KEY:

*-VENDOR ITEM - FOR PROCUREMENT OR PART NUMBER SEE SPECIFICATION CONTROL OR SOURCE CONTROL DRAWING

F- FEET
I- INCHES

B- BULK
A/R- AS REQUIRED
R- REFERENCE

PL

CODE IDENT 07397

SHEET 9 OF 11

REV

NOTES:

PLATS

QUANTITY REQUIRED				KEY	CODE IDENT	PART OR IDENTIFYING NO.	GTE SYLVANIA PART NO.	NOMENCLATURE OR DESCRIPTION	NOTE	ITEM NO.
			-1		PS1	SPS 15-12	STANDARD POWER	POWER SUPPLY, 12 VDC		
			1		DS1			INDICATOR, POWER, PART OF S1		
			1		DS2			↑ #330 BULB, YELLOW LENS		
			1		DS3			↓ #330 BULB, GREEN LENS		
			1		DS4			INDICATOR, #330 BULB, RED LENS		
			1		F1			1/2 AMP FUSE WITH HOLDER		
			1		S1			SWITCH, POWER, WITH INDICATOR DS4		
			1		S2			↑ N.O. PUSH BUTTON		
			3		S3			↓ TOGGLE, SPDT		
			-		S4			↓ TOGGLE, SPDT		
			-		S5			SWITCH, TOGGLE, SPDT		
			1		K1	603-12V	GDE	RELAY		
			1		AI1	SG 628P	MALLORY	SONALERT		

KEY:

*-VENDOR ITEM - FOR PROCUREMENT OR PART NUMBER SEE SPECIFICATION CONTROL OR SOURCE CONTROL DRAWING

F- FEET
I- INCHES

B- BULK
A/R- AS REQUIRED
R- REFERENCE

PL

CODE IDENT 07397

SHEET 10 OF 11

REV

NOTES:

PLATS

QUANTITY REQUIRED				KEY	CODE IDENT	PART OR IDENTIFYING NO.	GTE SYLVANIA PART NO.	NOMENCLATURE OR DESCRIPTION	NOTE	ITEM NO.
		-1								
		1			SC-13100	BUD		CHASSIS		
		1						LINE CORD		
		1						TERMINAL STRIP (3 SCREW TERMINALS)		
		AIR						#20 MAGNET WIRE		
		AIR						#24 MAGNET WIRE		

KEY:

*-VENDOR ITEM - FOR PROCUREMENT OR PART NUMBER SEE SPECIFICATION CONTROL OR SOURCE CONTROL DRAWING

F- FEET
I- INCHES

B- BULK
A/R- AS REQUIRED
R- REFERENCE

PL

CODE IDENT 07397

SHEET 11 OF 11

REV

4.0 TESTING AND RESULTS

4.1 TEST PROCEDURE

The completed Power Line Alarm Transmission System hardware was tested in accordance with a previously generated test plan. The test plan was modified on several points to make the test procedures compatible with the final system hardware. These modifications are described in the specific test section of this report.

The test plan was composed of two basic types of tests: laboratory tests and operational tests. The laboratory tests were performed on the laboratory bench and were designed to identify the operating limits of several system parameters. The operational tests were performed at an actual residential location. Most of these operational tests were performed at the single family townhouse residence identified as Location 2 in the Phase I Power System Characterization Report previously delivered under this same contract. For maximum consistency, the outlet and circuit identification used for Location 2 in this report is identical with that used in the site characterization of the Phase I Report.

Those operational tests which could not be conveniently performed at Location 2 were performed at a site hereafter identified as Location 5. This site was a single story, single family residence of approximately 1700 square feet and two years in age. Modern electrical wiring practices were used throughout the residence, and a safety ground was present at all circuit outlets. A complete characterization of Location 5 was not performed.

4.2 TEST RESULTS

4.2.1 Safety Test

This test was performed to ascertain that unsafe voltages do not appear on user-accessible parts of either the Shunt Impedance Switch transmitter or the Receiver/Control Unit. The units were connected to a 60 Hz 120 volt AC power line, and voltages were measured using an HP 3400A RMS voltmeter. The test results revealed no voltages present except at the screw terminals of the SIS. These terminals are transformer isolated and current limited by the SIS circuit. An open circuit voltage of approximately 4 VRMS was present between the two terminals. No unsafe voltages were found on any accessible part of the system.

It is pointed out at this time that the present equipment design did not include a comprehensive safety analysis nor was the equipment specifically designed for UL approval

4.2.1 (Continued)

in its present form. This is in keeping with the fact that the system was designed to demonstrate the feasibility of a concept and not for immediate commercial application. Safety requirements will be very important in a production engineered version of the system, however. The feasibility model includes safety grounding of the Receiver/Control Unit chassis but not the SIS chassis. This was done to keep the SIS compatible with 2-wire power line systems without the use of a 2-wire adapter which would almost double the physical size of the SIS. Production engineered versions of the SIS would require a double insulation scheme which would probably require an insulating case material. Safety considerations were also important in the transformer coupled design of the SIS. This design does not require attention to the power line polarity in order to prevent dangerous voltages from appearing at the connector terminals.

4.2.2 Sensitivity/Series Resistance Test

As originally presented in the Test Plan this test was designed to utilize power provided by a 60 Hz power inverter. This configuration was intended to isolate the Power Line Alarm Transmission System from the effects of an uncharacterized power circuit. The Power Line Alarm Transmission System in its current form is incompatible with certain active devices which place a modulated impedance characteristic on the power line. This fact will be elaborated upon in the subsequent sections of this report. At this point, however, it is sufficient to note that the Power Line Alarm Transmission System is incompatible with the power inverter due to the impedance fluctuations produced by the inverter. Instead of connecting the system to a standard 60 Hz supply and introducing the unknown impedance effects of that supply, it was decided to perform this test without connection to a 60 Hz power system. The 12 volt DC supply which is internal to the Receiver/Control Unit was disconnected. The Receiver/Control Unit was powered from an external 12 volt DC supply and the system was set up in the test configuration shown in Figure 4-1.

As shown in this figure, the Receiver/Control Unit and the SIS were connected together using short leads, a shunt resistor R_y and a series resistor, R_x . For fixed values of R_y , R_x was increased in value until an alarm could not be obtained upon actuation of the SIS. R_y values were chosen to represent the shunt effect of a 60 Hz power system based on the results of the earlier power line characterization. Figure 4-1 also contains a table showing the results of this test and the computed attenuation factor, α . α was computed assuming an input impedance to the SIS of 4.5 ohms at resonance and a Receiver/Control Unit source impedance of 100 ohms.

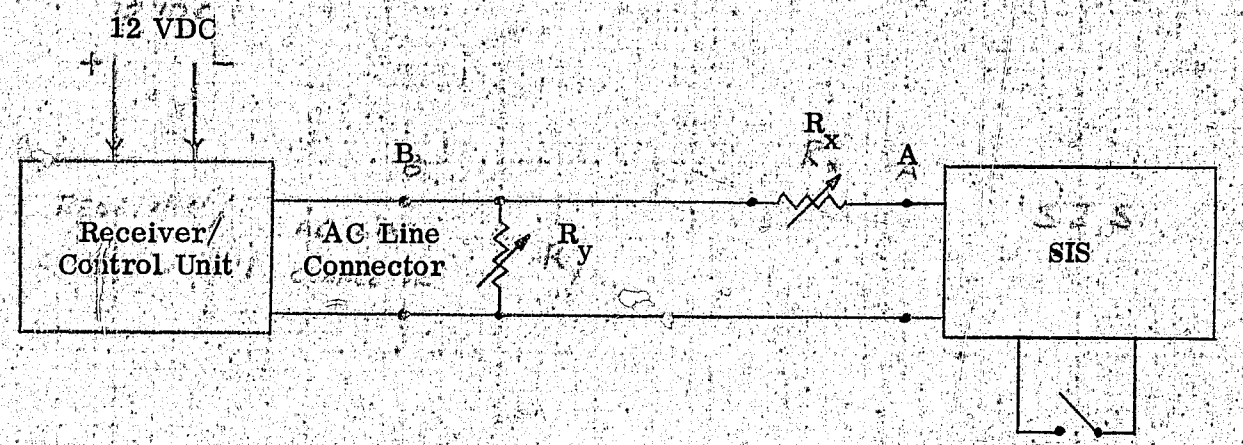

R_y , Ohms	R_x , Ohms	$\alpha = \frac{V_A}{V_B}$, dB
∞	89	-26.4
75	70	-24.4
50	62	-23.4
27	45	-20.8
10	25	-16.3

Figure 4-1. Sensitivity/Series Resistance Test Setup

4.2.3 Active Noise Test

This test was performed to determine the noise level which can be tolerated by the system without producing a false alarm. The test configuration is shown in Figure 4-2. As in the previous test, an external 12 volt DC supply was used to provide power to the Receiver/Control Unit, and the system was not connected to a 60 Hz power line. This was done to prevent the entrance of uncharacterized power system effects into the test. The Receiver/Control Unit and the SIS were connected together using short leads and a shunt variable resistor R_y . Noise was introduced into the system using a standard noise generator with a 500 kHz bandwidth and a wideband power amplifier. Noise measurements were made using a true RMS voltmeter. R_y values were chosen based on the earlier power line characterization study and are believed to represent realistic shunt impedances which may be produced by a power system at the 110 kHz operating frequency. The results of this test are shown on Figure 4-2. An RMS noise level of approximately 0.25 volts was required for false alarm and this value was substantially independent of the shunt impedance. Alarms due to a real SIS actuation were not inhibited at any noise level up to the false alarm level.

4.2.4 Switching Noise Test

This test was performed to determine the false alarm susceptibility of the system to the rapid switching of a heavy load on and off the power line. The test configuration is shown in Figure 4-3. As shown in the figure, the Receiver/Control Unit was connected to a 110 volt 60 Hz supply present at the laboratory bench. This supply was uncharacterized. A 1320 watt heater element load was switched on and off of the power line by means of a power relay. This power relay was in turn switched by a 24 volt switching relay powered from a transistor switching circuit. The source of the switching signal was a single pulse generator. This setup facilitated variation of the switching frequency while maintaining a 50% duty cycle. The switching frequency was varied over a range covering 0.2 Hz to 18 Hz. False alarms were noted at a switching frequency of 5 Hz and above. Alarms due to real SIS actuations were not inhibited at switching frequencies below 5 Hz.

4.2.5 Activation Time Tests

This test was performed to determine the minimum SIS actuation time necessary to produce an alarm. The test configuration is shown in Figure 4-4. As shown in the figure, the Receiver/Control Unit was powered from an external 12 volt DC supply with no connection being made to an external 60 Hz supply. The SIS and Receiver/Control

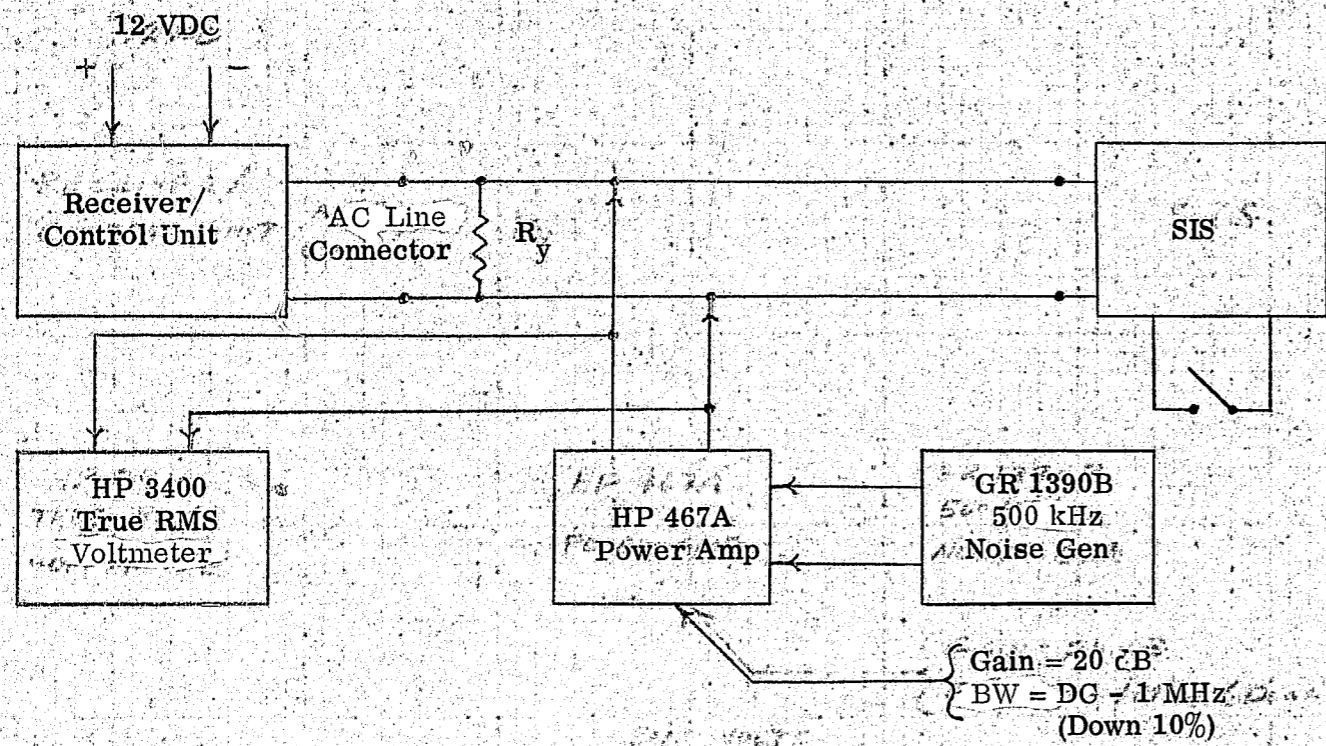

R_y , Ohms
8
75
50
27
10

RMS Volts for Alarm
0.25
0.25
0.26
0.27
0.22

Gain = -20 dB
 BW = DC - 1 MHz
 (Down 10%)

Figure 4-2. Active Noise Test Setup and Results

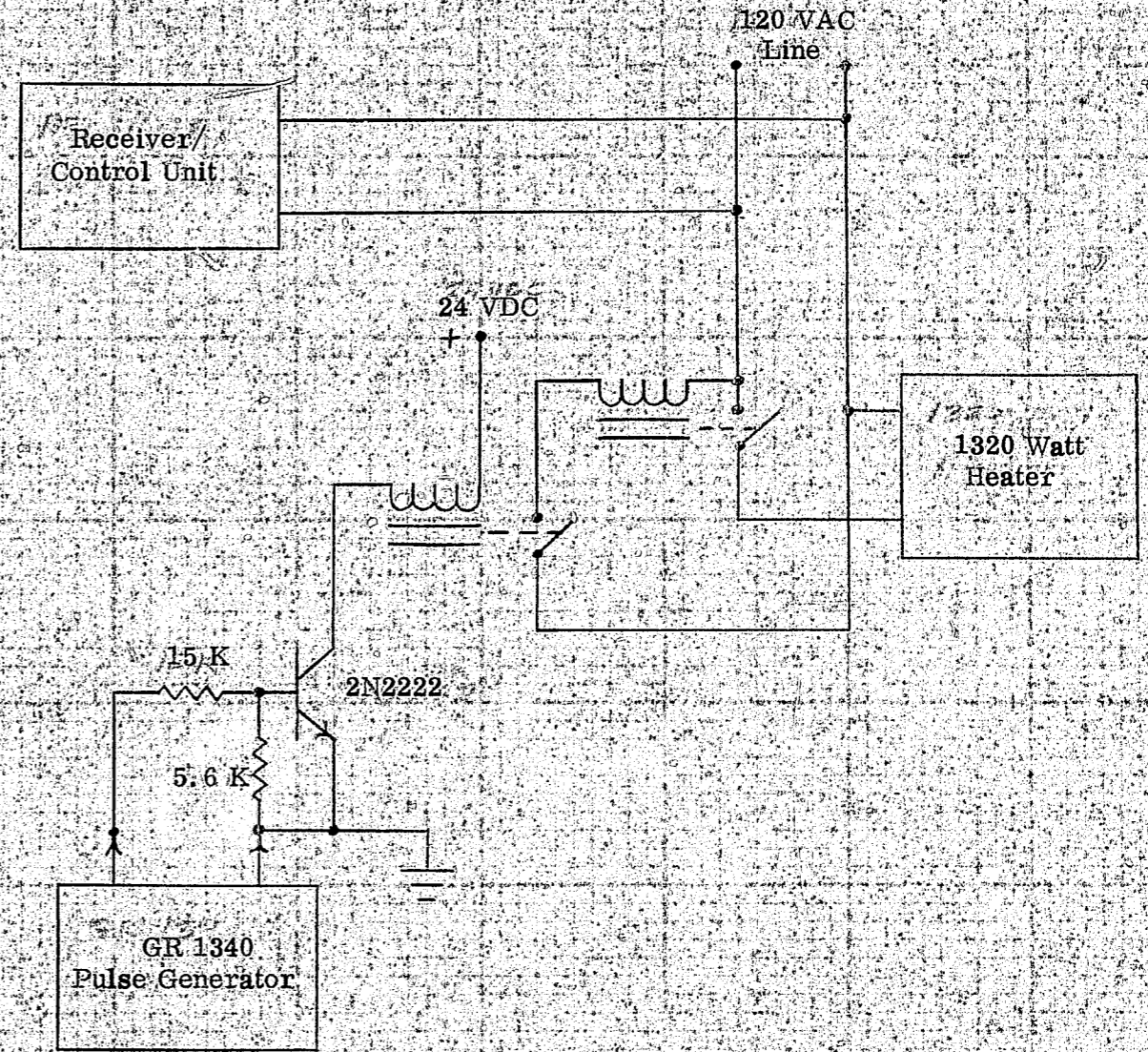
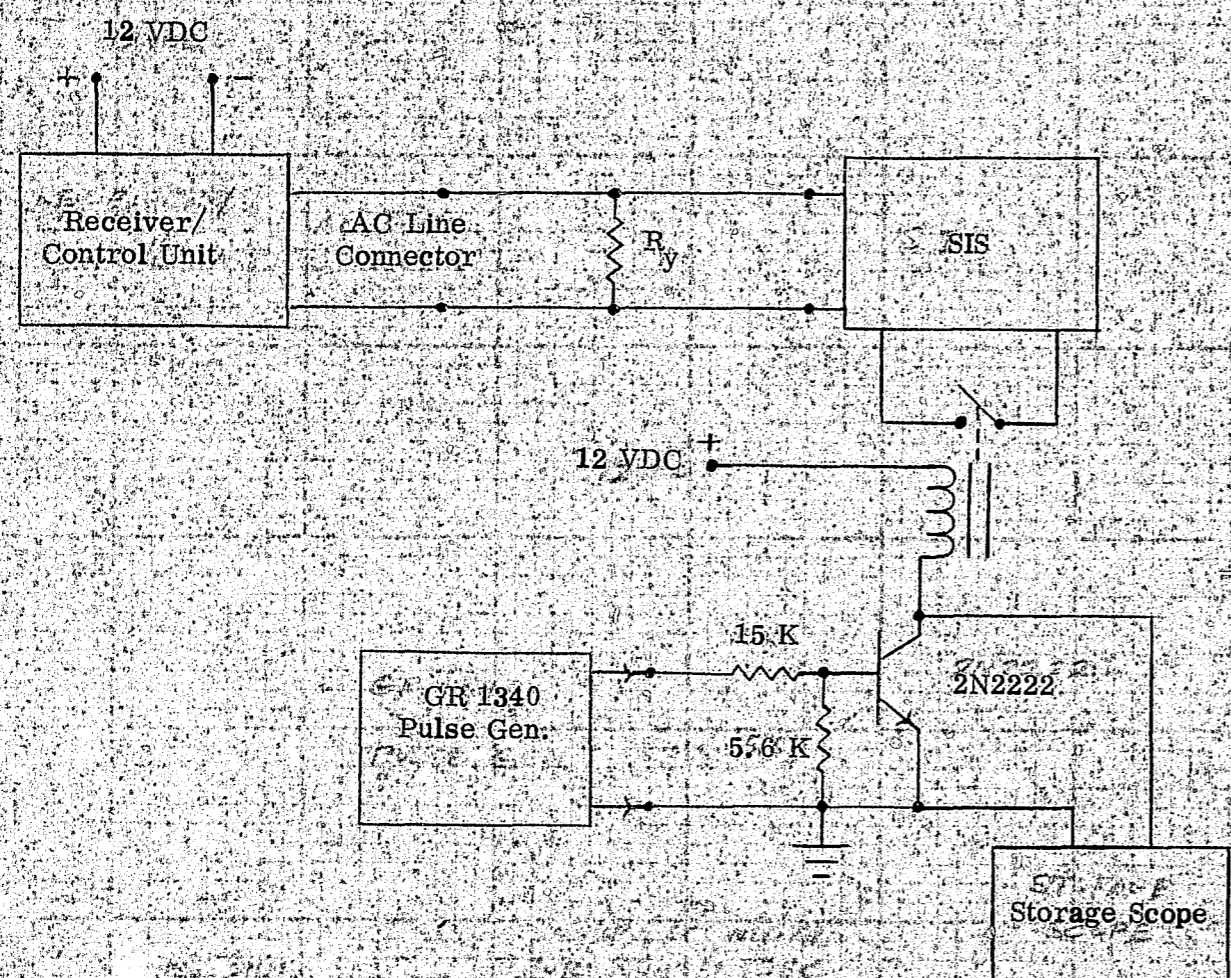

Figure 4-3. Switching Noise Test Setup



R_y , Ohms	Min. Pulse Width for Alarm, Sec
∞	0.7
75	0.8
50	0.8
27	0.8
10	0.8

Figure 4-4. Activation Time Test Setup and Results.

4.2.5 (Continued)

Unit were connected together using short leads and a shunt resistor R_y . Again, R_y values were chosen to be representative of the shunt impedance produced by a typical power system at the 110 kHz frequency. The SIS terminals were actuated using a fast acting mercury wetted relay. This relay was driven from a transistor source which was in turn driven from a single pulse generator. Closure times were measured using a storage oscilloscope. The results are also presented on Figure 4-4 and reveal a minimum closure time of about 0.8 seconds independent of the shunt resistance value.

4.2.6 Alarm Verification Test

This test and all of the following tests are operational tests and were performed at residential test sites. The purpose of this test was to confirm the operation of the various functions appearing on the Receiver/Control Unit. The test was performed at Location 2 with both the Receiver/Control Unit and the SIS connected to outlet 9-6. The SIS transmitter was actuated by means of a toggle switch. The unit was tested for proper operation of the visual alarm indicator, the aural alarm indicator, the aural alarm defeat switch, the alarm relay, the secure/access switch, and the reset switch. All functions operated satisfactorily.

4.2.7 Signal Transmission Test

This test, performed at the well characterized Location 2, was designed to test the signal transmission of the system between various circuits connected both to the same and to different sides of the power transformer. All loads were removed from the power system at Location 2. A capacitive bridging circuit was used to cross couple the two sides of the power transformer. This coupling circuit consisted of a $0.47 \mu F$ capacitor housed in a plug suitable for connection to the 220 volt household clothes dryer socket. The results of the signal transmission testing are presented in the following sections.

Circuit descriptions appear in Figure 4-5 through 4-9.

4.2.7.1

Receiver Control Unit	Circuit 9-6, Transformer Phase A
SIS	Circuit 9-3, Transformer Phase A
PLATS Alarm Verified	Yes

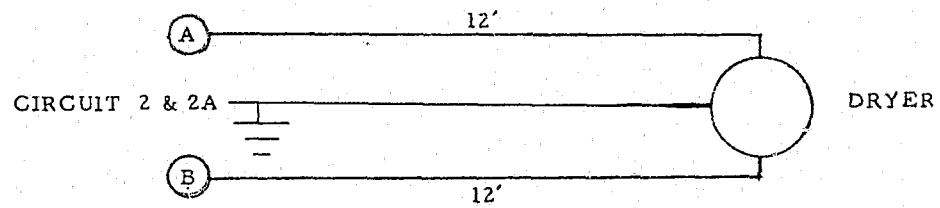
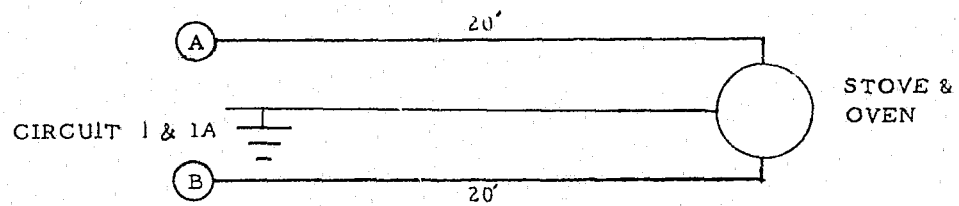
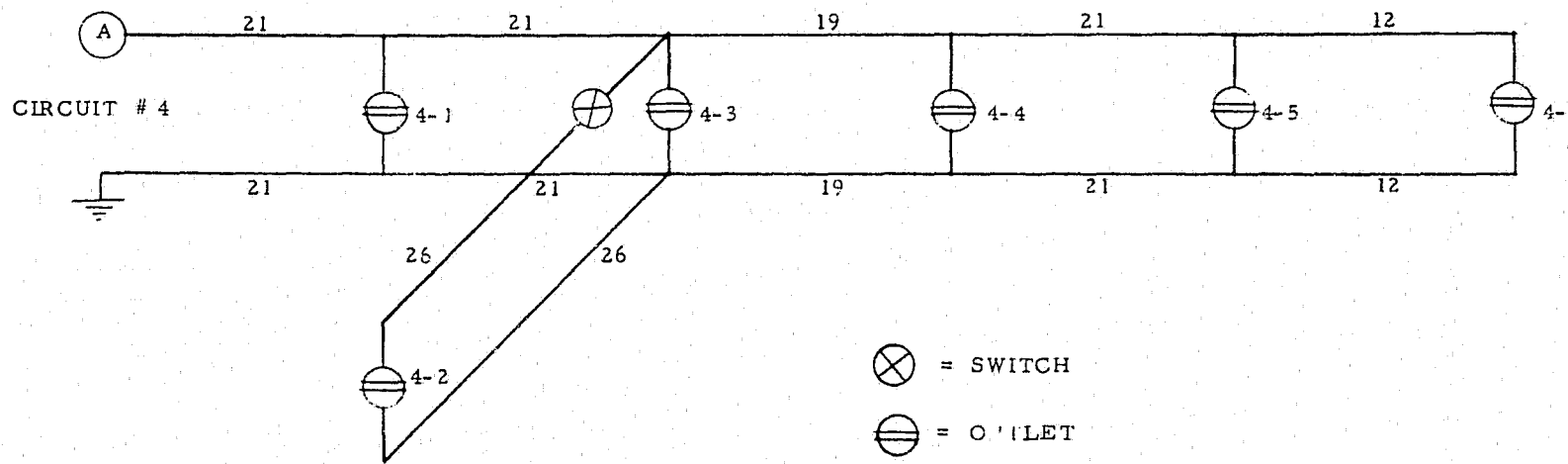
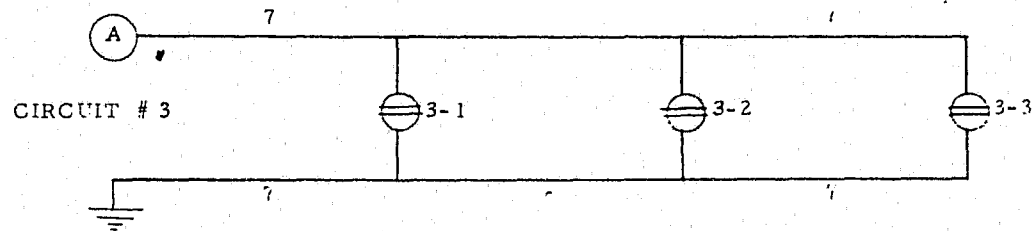

FIGURE 4-5: LOCATION 2--WIRING CONFIGURATION, CKTS 1 & 2



⊗ = SWITCH
 ⊖ = OUTLET

A third wire not shown (the safety ground) is common with the neutral conductor at the meter box, is carried through all outlet circuits, and appears at the ground connector of each outlet.

FIGURE 4-6: LOCATION 2--WIRING CONFIGURATION, CKTS 3 & 4

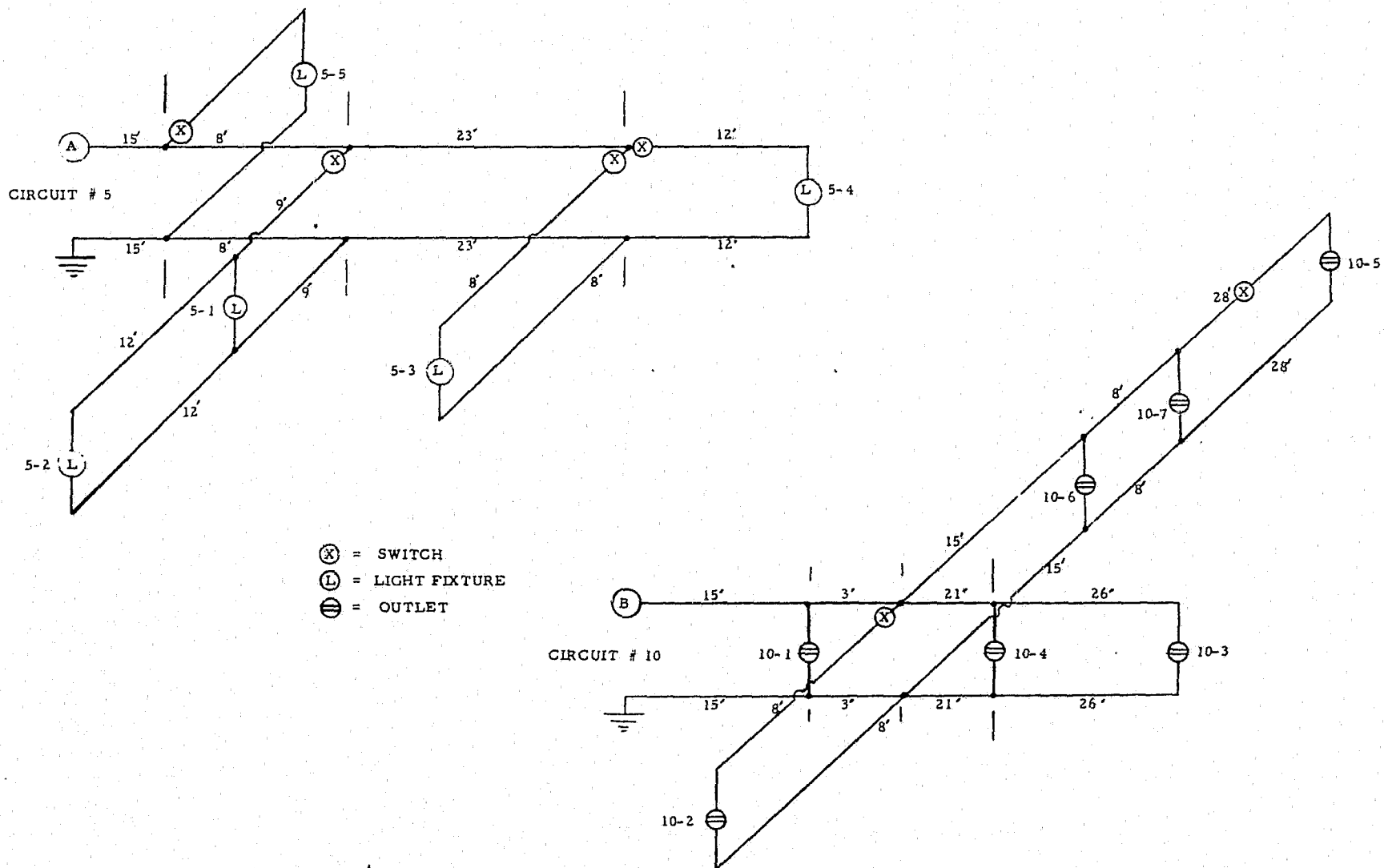

A third wire not shown (the safety ground) is common with the neutral conductor at the meter box, is carried through all outlet circuits, and appears at the ground connector of each outlet.

FIGURE 4-7: LOCATION 2-WIRING CONFIGURATION, CKTS 5 & 10

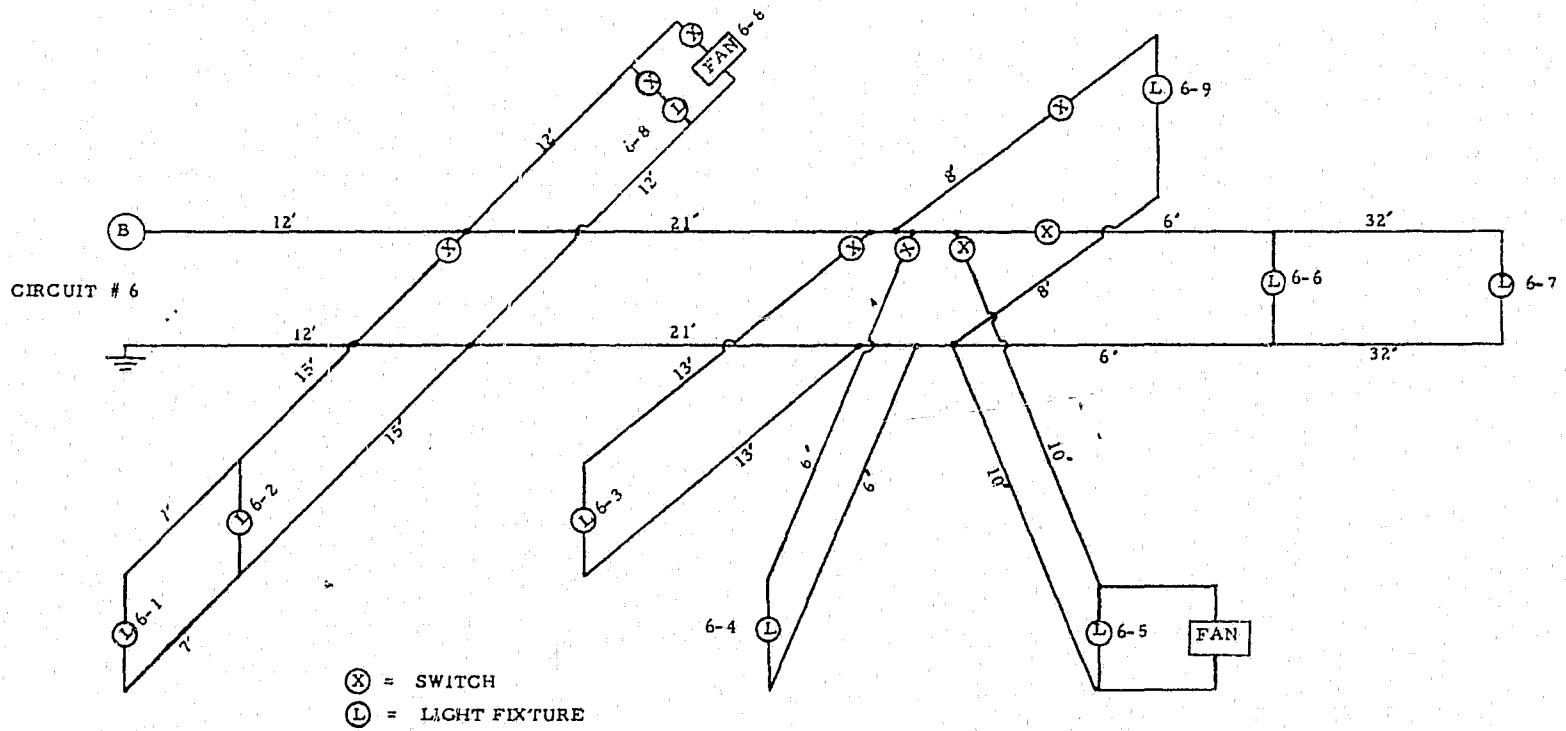

FIGURE 4-8: LOCATION AND WIRING CONFIGURATION, CKT 6

A third wire not shown (the safety ground) is common with the neutral conductor at the meter box, is carried through all outlet circuits, and appears at the ground connector of each outlet.

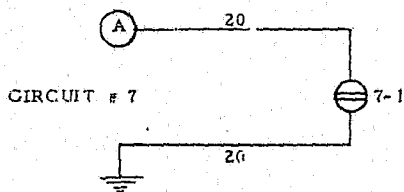
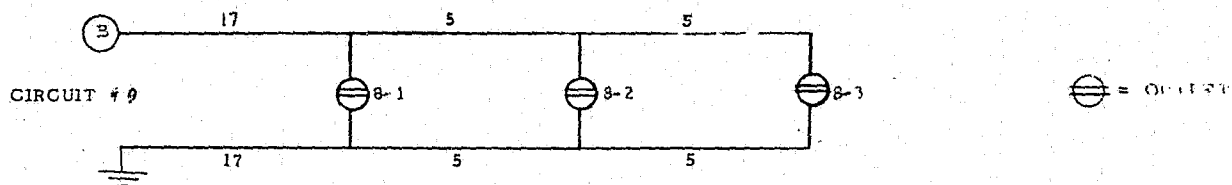
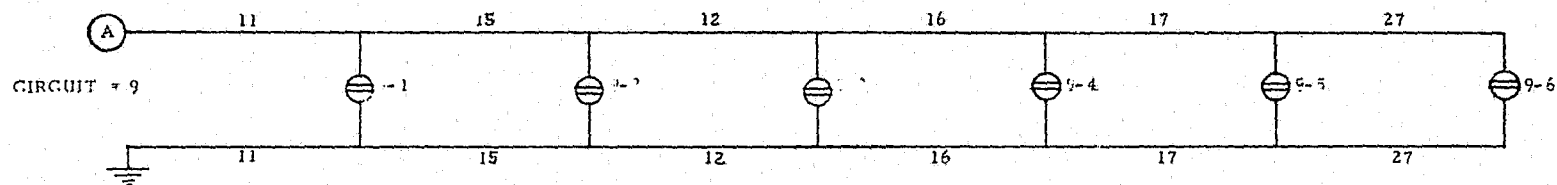

FIGURE 4-9: LOCATION 2--WIRING CONFIGURATION, CKTS 7, 8, & 9

4.2.7.2

Receiver Control Unit
SIS
PLATS Alarm Verified

Circuit 9-6, Transformer Phase A
Circuit 4-3, Transformer Phase A
Yes

4.2.7.3

Receiver Control Unit
SIS
PLATS Alarm Verified

Circuit 9-6, Transformer Phase A
Circuit 8-2, Transformer Phase B
Yes

4.2.8 Loading Tests

It was the purpose of the loading tests to determine the ability of the Power Line Alarm Transmission System to operate between various circuits under the conditions of a heavy load. This test was performed at Location 2 with all power line loads removed from the system. Two portable electric heaters of 1320 watts each were selected to represent worst case conditions and were used as loads throughout the test. The results of the test are presented in the following sections.

4.2.8.1

Load - 2640 watt heaters
Receiver Control Unit
SIS
PLATS Alarm Verified

Circuit 9-5, Transformer Phase A
Circuit 9-2, Transformer Phase A
Circuit 9-6, Transformer Phase A
Yes

Load - 2640 watt heaters
Receiver Control Unit
SIS
PLATS Alarm Verified

Circuit 9-5, Transformer Phase A
Circuit 9-2, Transformer Phase A
Circuit 3-2, Transformer Phase A
Yes

Load - 2640 watt heaters
Receiver Control Unit
SIS
PLATS Alarm Verified

Circuit 9-5, Transformer Phase A
Circuit 9-2, Transformer Phase A
Circuit 8-2, Transformer Phase B
Yes

4.2.8.2

Load - 2640 watt heaters
Receiver Control Unit
SIS
PLATS Alarm Verified

Circuit 9-5, Transformer Phase A
Circuit 3-2, Transformer Phase A
Circuit 9-2, Transformer Phase A
Yes

Load - 2640 watt heaters
Receiver Control Unit
SIS
PLATS Alarm Verified

Circuit 9-5, Transformer Phase A
Circuit 8-2, Transformer Phase B
Circuit 9-2, Transformer Phase A
Yes

4.2.8.3

Load Number 1 - 1320 watt heater
Load Number 2 - 1320 watt heater
Receiver Control Unit
SIS
PLATS Alarm Verified

Circuit 9-5, Transformer Phase A
Circuit 3-2, Transformer Phase A
Circuit 3-3, Transformer Phase A
Circuit 9-6, Transformer Phase A
No alarm with both loads on. Alarm verified with either load off.

Load Number 1 - 1320 watt heater
Load Number 2 - 1320 watt heater
Receiver Control Unit
SIS
PLATS Alarm Verified

Circuit 9-5, Transformer Phase A
Circuit 8-2, Transformer Phase B
Circuit 8-3, Transformer Phase B
Circuit 9-6, Transformer Phase A
No alarm with both loads on. Alarm verified with either load off.

4.2.9 Line Noise Rejection Tests

This test was performed at Location 2 with all loads removed from the power system and using a 3/8" electric drill motor as a line noise source. This universal brush type motor was connected at circuit 9-2, transformer phase A. The results of the test are presented in the following sections.

4.2.9.1

Receiver Control Unit
SIS
PLATS Alarm Verified
False Alarms

Circuit 9-5, Transformer Phase A
Circuit 9-6, Transformer Phase A
Yes
None

4.2.9.2

Receiver Control Unit	Circuit 9-5, Transformer Phase A
SIS	Circuit 3-2, Transformer Phase A
PLATS Alarm Verified	Yes
False Alarms	None

4.2.9.3

Receiver Control Unit	Circuit 9-5, Transformer Phase A
SIS	Circuit 8-2, Transformer Phase B
PLATS Alarm Verified	Yes
False Alarms	None

Also note that no false alarms were induced by starting transients at any time during the above tests.

4.2.10 EMI Tests

This test was performed to determine if interference effects exist between the Power Line Alarm Transmission System and commercial broadcast radio and television receivers. Because of the inaccessibility of such receivers at Location 2, this test was performed at Location 5. Location 5 has been previously described but has not been characterized in terms of the power system interconnections. The first test was performed using a Heath 25 inch color console television receiver. Both the television receiver and the Receiver/Control Unit were connected to the same circuit outlet. No interference was exhibited in either the audio or video of the television receiver. No false alarms were induced in the PLATS system. In a second test, an Admiral table model AM broadcast receiver was used. Both the AM receiver and the Receiver/Control Unit were connected to the same circuit outlet. No interference was exhibited in the audio output of the AM receiver. A continuous non-resettable false alarm was exhibited in the Receiver/Control Unit. It is noted here that the circuit design of the AM broadcast receiver utilizes a transformerless type power supply. In a third test a Scott LR-88 FM broadcast receiver was used. Both the FM receiver and the Receiver/Control Unit were connected to the same circuit outlet. No interference was exhibited in the audio output of the FM receiver. No false alarms were induced in the PLATS system.

4.2.11 False Alarm Tests

Tests were performed to indicate the susceptibility of the Power Line Alarm Transmission System to household false alarm sources. The first test was a load switching test using a 1320 watt heater as a circuit load. This test was performed at Location 2 with both the load and the Receiver/Control Unit connected to circuit 9-5. The load

4.2.11 (Continued)

was manually switched on and off at a rapid rate. False alarms were exhibited during this test. The load was switched off and on approximately three to five times per second in order to produce the false alarm. Note that the results of this test are in agreement with the results of the laboratory load switching test of section 4.2.4.

A second test was conducted using a 3/8" universal electric drill motor as a false alarm source. Both the drill motor and the Receiver/Control Unit were connected to circuit 9-5 of Location 2. The motor was rapidly switched on and off. No false alarms were exhibited. This test was repeated with both a General Electric garbage disposal unit and the Receiver/Control Unit connected to circuit 7-1 at Location 2. Again, no false alarms were obtained.

A third test was intended to determine the susceptibility of the unit to false alarms induced by the normal household operation of various appliances. This test was performed at Location 5 and ran a total of 30 hours. The Receiver/Control Unit was connected to a circuit outlet and allowed to run continuously during normal household operation. The test was run in two 15 hour blocks. During this time period two resettable false alarms occurred. These alarms were approximately five minutes apart and did not correlate with the start-up of any appliances at the test site. In addition, none of the heavy heating load appliances were in operation during the false alarms which occurred.

4.2.12 Multiple Sensor Tests

This test was used to verify the operation of the Power Line Alarm Transmission System when set up in a typical security configuration utilizing a switch mat, a magnetic door switch, and a photoelectric beam interrupter. The test was performed at Location 2. The Receiver/Control Unit was connected to circuit 9-5 on transformer phase A. The switch mat was connected to a SIS at circuit 4-3 on transformer phase A. A magnetic door switch was connected to a SIS at circuit 3-3 on transformer phase A. A latching photoelectric beam interrupter was connected to a SIS at circuit 8-2 on transformer phase B. Alarms were verified upon the operation of all of these detection devices.

5.0 OPERATING PROCEDURES AND LIMITATIONS

It should be the objective of any system test plan to give evidence of both the areas of excellence and any weaknesses which exist in the system being tested. That this has been done is demonstrated by the results of the tests presented in the previous sections. These tests reveal that the Power Line Alarm Transmission System in its present form does represent a feasible concept. The test results also demonstrate, however, that certain weaknesses exist which must be corrected in the hardware development phase of the program in order to make the system a viable alternative for the residential security alarm application.

The results of the test described in Section 4 of this report demonstrate that the Power Line Alarm Transmission System has good reliability in terms of detection of a SIS activation. The system provided extremely good coverage over a complex power wiring system which would be typical of many modern residential configurations. Tests performed during the engineering evaluation of the system and prior to the initiation of the actual test plan revealed that the use of the simple capacitive coupler applied to a 220 volt outlet in order to connect the two sides of the power transformer provided complete coverage of the residential power system at Location 2. SIS activations could be detected by the Receiver/Control Unit from any outlet in the residence under any load condition presented by the appliances in the residence. This test was performed at Location 2 and the loads used included all of the heavy heating load appliances, i.e., the oven and heater elements. It included motor sources such as air conditioners, garbage disposals, and refrigeration units, and no false alarms were initiated by any of these devices. The system also demonstrated a high noise immunity as evidenced by its failure to false alarm when subjected to the high noise output of such devices as universal brush type motors.

The primary weakness of the present Power Line Alarm Transmission System lies in the area of false alarm susceptibility. Tests show the system to be relatively unaffected by the broad spectrum noise originating in such devices as brush type motors and SCR lamp dimmer circuits. Not a single false alarm was obtained from sources of this nature at any time during testing. In addition, the system appears immune to false alarms caused by isolated starting transients from motors and heavy resistive loads. The system is susceptible to false alarms from at least two sources, however. One of these sources, and perhaps the one most commonly to be encountered in a residential environment, includes certain types of broadcast receivers which use a transformerless

5.0 (Continued)

power supply. Such devices typically obtain their DC power from voltage doubler and rectification networks. These networks include combinations of diodes and capacitors and were revealed by our tests to cause an impedance modulation of the power lines at the frequency of operation of the Power Line Alarm Transmission System. Enough of this modulation energy lies in the PLATS signal band to result in a definite false alarm which is usually non-resettable. Tests at Location 5 using a small AM broadcast receiver yielded false alarms whenever there was relatively little power line circuit separation between the broadcast receiver and the PLATS Receiver/Control Unit. Increasing the separation distance between these two units resulted in only occasional false alarms. The use of a portable television set with a transformerless power supply, however, resulted in false alarms at Location 5 regardless of circuit separation between the PLATS and the broadcast receiver.

False alarms were also induced in the PLATS Receiver/Control Unit by the rapid switching of a heavy heating element load. This was confirmed in both the laboratory tests and the operational tests at Location 2. It must be pointed out that the starting transients due to single switching of such loads at no time produced a false alarm during the tests. Only rapid on and off switching for over a second was shown to produce alarms. As described in a previous section of this report, the PLATS Receiver/Control Unit uses an up/down counter as a digital integrator. While an isolated load switching transient may produce enough line impedance change to trigger the threshold circuit, this only moves the counter to a count of 1. Thresholds must be triggered on successive sweeps for the counter to continue counting upwards to the system alarm threshold. If no threshold trigger occurs on the successive sweep, the counter counts back down to 0. Thus, a load must be switched on and off at a rate high enough to produce a transient trigger on more than half of the frequency sweeps in order for the counter to eventually reach the system alarm threshold. Such a condition is possible but unlikely in the normal operation of residential appliances.

An alarm failure was experienced during the system load tests of Section 4.2.8.3. In this test the system failed to alarm when the SIS was actuated under

5.0 (Continued)

an extreme load condition. This test was chosen so as to present a worst-case load condition to the system at Location 2. The system was set-up with the Receiver/Control Unit at the end of a branch circuit with a heavy heating load near the same outlet on this circuit. The SIS was placed at the end of a second branch circuit with another heavy heating load only a short circuit distance from the SIS. Under these conditions, the SIS activation failed to produce an alarm when both heaters were on. The removal of either load yielded good alarm operation. In addition, the replacement of both loads together near the center of the circuit path also produced reliable alarm conditions. This test demonstrates a possible failure mode of the system in its present form. However, the test was an extreme case and used a configuration which is not highly probable in the normal residential use of the system. This is particularly true in view of the fact that heavy heating element loads are often localized on special circuits. Those loads which are normally used during non-occupancy, such as timer controlled ovens, presented no false alarms nor alarm failures when used with the PLATS system at Location 2.

It must also be pointed out that a potential failure mode for the system is inherent in the long integrating interval required for an alarm. The tests revealed a minimum SIS actuation requirement of about 8/10ths of one second. Intrusion detection devices which produce a SIS actuation shorter than this interval will not result in an alarm.

A number of implications are drawn from the results of the tests performed on the PLATS system. The feasibility of the PLATS concept is amply demonstrated. The system provides good coverage of a typical residential power wiring configuration when used with a simple capacitive coupler to provide a signal path between the two sides of the power transformer. This coverage is flexible and avoids the need for hardwiring between the detectors and the receiver/control unit. In addition, the passive SIS concept removes the requirement for a back-up power supply in the remote alarm switches. The system may be used with many types of intrusion detectors. The single detector requirement is that the detector be capable of producing a switch closure of about one second minimum duration. Detectors such

5.0 (Continued)

as photoelectric beam-breakers and ultrasonic volume detectors require a latching function to produce reliable SIS alarms. Such latching functions are commonly part of the detector design. In those cases where this is not true, simple modifications of existing circuits often produce the required result. The switch closure time provided by a magnetic door switch is deemed to be sufficient to produce reliable SIS alarms. Switch mats, however, present the greatest problem in terms of actuation time. The passive switch mat is not normally amenable to a latching design. It is therefore necessary that the intruder remain on the mat for the minimum actuation time of about one second. Thus, the application of switch mats to a security system utilizing the unmodified PLATS design dictates the use of large mats and their strategic emplacement in such locations that the actuation time will be maximized.

The use of heavy heating loads with the PLATS system in its present design has the potential for decreasing the alarm detection range. This should be borne in mind when placing the SIS transmitters, and an effort should be made to provide the maximum circuit separation between heavy heating loads and the PLATS system components. This condition would not normally present a problem when the residence is unoccupied and such loads are not in use.

It is correctly implied from the test results that the operation of those electronic appliances which use a transformerless power supply, i. e., a diode and capacitor type supply, is incompatible with the operation of the PLATS system in its present form. This precludes use of the PLATS system (in its present unmodified form) in the relatively small percentage of cases in which such appliances would be in use while the residence is unoccupied and under the surveillance of the alarm system. Note, however, that two unexplained false alarms were obtained in the 30 hour test described in Section 4.2.11. No definite evidence exists as to the source of these alarms. However, it is quite possible that these alarms originated from the operation of devices having transformerless power supplies on other neighborhood circuits connected to the same power distribution transformer.

6.0 CONCLUSIONS AND RECOMMENDATIONS

It is concluded on the basis of the tests performed to date that the concept of a Power Line Alarm Transmission System using the passive Shunt Impedance Switch mode of sensing is both feasible and attractive for use in residential security system applications. The concept demonstration breadboard system delivered under this contract exhibits a high sensitivity which provided excellent coverage on typical residential power system configurations. Further, the system has a high immunity to false alarms from a wide variety of noise sources and varying impedance situations which occur on residential power systems. The results of system testing also reveal several areas in which additional engineering development is required. This is neither unusual nor unexpected in the concept development stage of any hardware program. The results obtained from the concept feasibility model are encouraging and indicate that the Power Line Alarm Transmission System should be elevated from a concept development to a hardware development status. Under this hardware development program further engineering development would be applied to the reduction of the system susceptibility to certain false alarm sources, such as transformerless power supplies and repetitive load switching, and to the increase of system alarm reliability under extreme circuit loading conditions.

Although the PLATS system concept was chosen partly on the basis of its potential for inexpensive implementation, thus producing a cost-effective residential security alarm system, the currently developed feasibility model was designed to demonstrate feasibility of the concept and was not designed specifically for low-cost high-volume production. The transition of the PLATS system from its present status as a proven concept to an inexpensive high-reliability residential alarm system will require both the engineering of a hardware development phase and full scale production engineering with a goal of maximizing the cost-effectiveness of the system concept. GTE Sylvania recommends that the Power Line Alarm Transmission System program be advanced from the concept development stage to the hardware development stage. We recommend a four-phase PLATS development program. The first phase of this program would be a hardware development phase directed specifically toward the engineering refinement of the system with regard to false alarm susceptibility and alarm activation reliability. Simultaneous with the hardware development phase, a computer modeling phase would be performed which would provide the tools whereby extensive power system characterization could be performed on any arbitrary power line configuration or scenario. This computer modeling was recommended as a result of the power line characterization

6.0 (Continued)

performed under this contract and presented in the Phase I report on Power System Characterization. It is maintained that the generation of such a computer model would be a valuable output of the Power Line Alarm Transmission System effort over and above the development of the cost-effective residential alarm system itself. Contingent upon the satisfactory accomplishment of the hardware development phase, phase three would accomplish a complete production engineering of the Power Line Alarm Transmission System suitable for inexpensive, high volume production and application to residential security problems. A fourth program phase would accomplish extensive field testing of the low cost PLATS system in order to provide a data base for the evaluation of system applicability under the geographical and constructional variations which exist in residential power wiring systems. Details of the proposed program continuation are set forth in the Statement of Work which follows. Inherent in this work statement is the capability of restructuring the program by combining phases I and II and phases III and IV to arrive at a two-phase effort.

6.1 Recommendations for Methods of Improvement

There are two main weaknesses in the PLATS feasibility model. They are as follows:

- (1) False alarm susceptibility to various transient and continuous line impedance variations caused by transformerless rectifier-capacitor power supplies and rapidly switched loads (5 to 120 ON-OFF cycles per second).
- (2) Alarm sensitivity reduction due to heavy loading of the power lines and, in some instances, due to long power line runs between the SIS and the Receiver/Control Unit.

There are several changes that can be made in the basic control unit design parameters that would probably eliminate the above problems. They are as follows:

- (1) Reduce operating frequency.
- (2) Reduce sweep width.

6.1 (Continued)

- (3) Increase carrier amplitude.
- (4) Decrease post-detection bandwidth and steepen filter skirts.
- (5) Optimize sweep rate.
- (6) Optimize processing techniques.
- (7) Lower Receiver/Control Unit source impedance.

Lowering of the operating frequency down to the range of 40 to 60 kHz is feasible if the carrier amplitude is also raised and sweep width decreased. The problems arising when frequency is lowered are caused by a decrease in the apparent utility system shunt impedance and the low shunt impedances of some loads combined with a rise in the power line ambient noise level.

Raising the carrier amplitude and decreasing the input filter bandwidth would compensate for the noise increase while the lower impedance of the SIS at resonance can compensate for the drop in utility and load shunt impedances. It should be remembered that keeping the Q of the SIS series resonant circuit constant while dropping the resonant frequency results in a desirable proportional drop of impedance at resonance ($R = \omega L/Q$, where R = equivalent series resistance of the circuit).

The sweep width can be reduced if the frequency is lowered because the tolerances that place a lower limit on the sweep width are a constant percentage of the center frequency and the resonant dip distortion effects caused by the power lines and loads are proportionately reduced at lower frequencies.

The post-detection bandwidth of the detector circuitry has a very significant effect on the SNR (signal-to-noise ratio) of the signal prior to final processing. It is probably the only analog signal conditioning parameter that can remove the undesirable 60 Hz and 120 Hz impedance modulation that is sometimes present on the power lines. Ideally, it should be made very narrow as to pass only the signal caused by the series-resonant dip, which is occurring at an approximately 2 Hz rate, but whose frequency content is considerably higher because the amplitude change due to the resonant dip occurs only during a portion of the sweep.

CONTINUED

1 OF 2

6.1 (Continued)

The post-detection filter can be made to have considerably greater skirt slopes by increasing the number of filter components using more complex active filter techniques.

The sweep rate and the signal processing techniques used after detection can have a great impact on range and false alarm susceptibility. The sweep rate was initially chosen to be approximately 17 Hz. This was set by the maximum sweep rate that could be used over the 104 to 116 kHz bandwidth to detect a resonant dip whose $Q = 160$. A fast sweep rate is desirable to minimize the effects of low frequency irregular load switching by providing a larger number of signal pulses per unit time for processing. Response time is also an important consideration because switch-mats and other switch-closure output devices may have relatively short closure durations (as short as 300 ms according to our test data). Therefore, in the presence of irregular, low frequency load switching noise and limited response time, faster sweep rates (and consequently increased information bandwidth) would increase the signal to noise ratio.

Unfortunately, we discovered that large power line impedance transitions occur at 60 Hz and 120 Hz rates. These impedance changes are also dependent on the carrier frequency position in the sweep range. This causes complex and unpredictable modulation patterns on top of the normal SIS resonant dip amplitude modulation. Since these undesirable modulation frequencies lie above the upper sweep rate frequency (~ 17 Hz) slowed sweep rates would make it easier to separate the noise modulation from the desired modulation by the use of filters.

To alleviate such problems the sweep rate of the control unit was placed at approximately 2 Hz. However, we feel that further optimization is possible when the interplay between various processing techniques, response time, and sweep rate is fully analyzed.

The signal processing employed in the Receiver/Control Unit uses a rather simple coincident threshold crossing counter. Much more sophisticated pattern recognition techniques could be employed to discern the simple, repeating signature caused by the SIS resonant dip. The use of these techniques will not necessarily result in a significantly more complex processor, but will result in a more

6.1 (Continued)

optimum design, able to function at greater ranges with significantly smaller false alarm rates.

The PLATS Receiver/Control Unit driving source impedance should be optimized. It was originally chosen as a compromise as discussed in Section 2.2.3. However, it could be further optimized when sufficient measurement and characterization of power lines has determined the typical expected values of power line impedance.

PLATS Program
PROPOSED STATEMENT OF WORK

Phase I - Hardware Development

1. Engineering Development - Increase false alarm immunity and alarm reliability
2. Fabrication of engineering development model
3. Laboratory and residential testing of engineering development model
4. Phase I Report - Results of engineering development effort

Phase II - Computer Simulation (Simultaneous with Phase I)

1. Additional analysis of power system characterization data
2. Generation of computer model and modeling techniques
4. Testing for model verification
5. Phase II Report - Results of computer simulation program

Phase III - Production Engineering

1. Engineering of overall system configuration
2. Value engineering for maximum reliability and minimum cost
3. Limited quantity fabrication of production model Power Line Alarm Transmission Systems
4. Laboratory and residential testing of production model
5. High volume production cost analysis
6. Phase III - Report - Results of production engineering, testing, and cost analysis

Phase IV - Field Testing

1. Test site analysis and selection
2. Performance/reliability testing
3. Analysis of system applicability
4. Phase IV Report - Results of test program

7.0 LOCATION/IDENTIFICATION SENSING

As part of the PLATS contractual effort, a requirement was made to briefly investigate location/identification sensing schemes which might be incorporated in a power line alarm system which uses an active carrier transmission technique. This information was considered useful primarily in the forthcoming Citizens' Alert System. The following paragraphs present the results of the location/identification sensing study.

7.1 PROBLEM STATEMENT

It is desired to define a near optimum system capable of transmitting a message indicating the distress, identification, and location of an individual located in close proximity to an electrical power line. The receiving station for this message is to be located near the same power line. Specifically, the system shall use the power line for the transmission medium and have sufficient capability to identify any U. S. citizen by number, such as Social Security Number, and place him at any one of up to 128 possible positions along the power line. A block diagram of the system is shown in Figure 7-1.

7.2 BASIC OPERATION

The basic operation of the system is described in the following paragraphs. An individual who is in distress activates his personal Distress Transmitter which sends a message containing his unique Identification Code (ID) number to the nearest Distress Receiver (it may be received by more than one receiver). The Distress Receiver receives the alarm message and activates the Power Line Transmitter which relays the coded distress message and adds its own unique location code to the individual's personal ID code. Thus, the message which is transmitted onto the power line contains both the identification and location of the individual in distress. This message is received and displayed at a central control location by the Alarm Display where appropriate action may be taken.

7.3 TECHNICAL DESCRIPTION

This discussion is not an attempt to design the specific system but rather a general technical description of the type of system which may be used to perform the required task using present day, cost-effective technology. We will, therefore, attempt to place bounds on the problem and make a reasonable first order estimate of the Power Line transmission portion of the system.

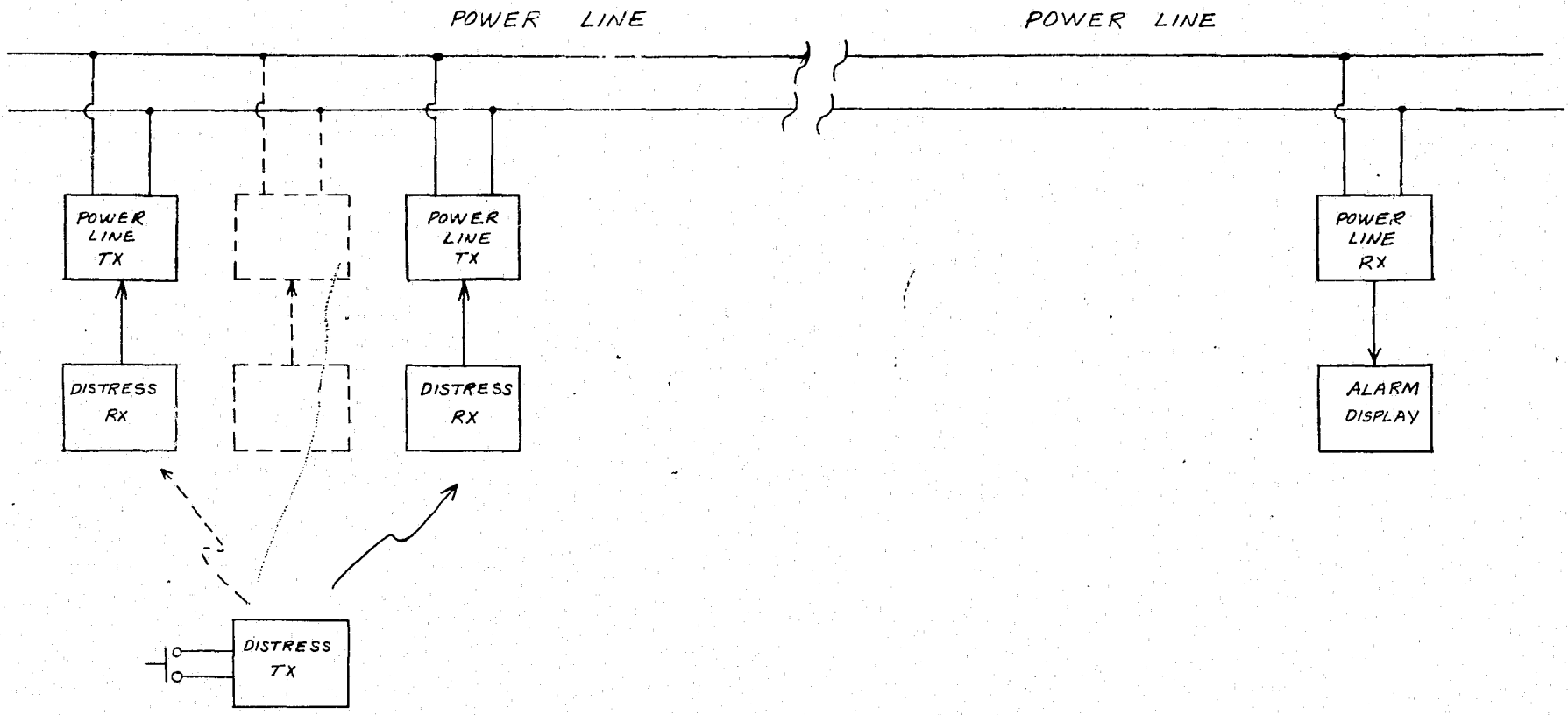

Figure 7-1. System Block Diagram

7.4 MESSAGE LENGTH

As it is desired to be able to identify most all adults in the USA by a unique ID code, a reasonable lower bound of 200 million and an upper bound of 1 billion ID numbers would be required. On the basis of a binary sequence the lower bound will be 28 bits and an upper bound of 30 bits will be required. To identify 128 locations along the power line an additional 7 binary bits will be required. Any additional message information, such as the nature of the distress, may be encoded by adding extra bits at either the distress or power line transmitter at a small percentage increase in message length. Of course, additional bits are required to provide for both bit synchronization and a frame marker. Usually, 5 to 7 bits will suffice in these burst type message formats. We may, therefore, conclude that a message length of $30+7+7 = 44$ binary bits will be required for such a general system.

7.5 POWER LINE TRANSMISSION

The general electric characteristics of power lines have been covered extensively in a previous report. As noted in these sections, the optimum frequency range for using an active system for data transmission is the 100 to 300 KHz range. On the basis of using tuned circuits with reasonable Q values, available RF transmission bandwidths of from 1 to 30 KHz may be considered, providing a maximum theoretical transmission bit rate of 2 to 60 K bits/second. For the sake of first order system design a bandwidth of 10 KHz will be considered with a corresponding 20 K bit maximum possible transmission rate. If we consider the use of modulation techniques which have symmetry about the carrier frequency such as ASK, FSK, or PSK the maximum bit rate will be 1/2 of the 20 KHz and if split phase codes are used in order to provide rapid bit synchronization another factor of 1/2 is introduced which reduces the maximum possible bit rate to 5 K bit in a 10 KHz band. Thus, the 44 bit message could be transmitted in approximately 9 msec. An overall message length of 10 msec will be assumed to allow for oscillator start-up time, etc.

7.6 MESSAGE STRUCTURE

The basic message format was outlined earlier and will consist of 44 bits which must be transmitted in a 10 KHz RF bandwidth in the 100 to 300 KHz range. The specific methods by which this may best be accomplished are contained in the following paragraphs.

7.6 (Continued)

In order to handle the basic problem of transmitting and displaying this amount of information, Pulse Code Modulation is the clear choice, as both the individual ID number and the location of the appropriate power line transmitter are converted immediately to digital format as the first step in the transmission process. Therefore, no further digital processing is required to provide either display or computer processing. Also, the digital information may be transmitted with as small an error rate as desired by proper code format selection. The code type and modulation remain to be selected.

The designer of a system for transmitting short bursts of pulse code modulation faces two particular problems. First, the receiver must handle a large dynamic range input signal with little or no time for an AGC loop to act on the signal. Second, bit and frame synchronization must be achieved in times which are short with respect to the message length if we are not to destroy the main advantage of such a system, i.e., the ability to time multiplex many messages onto a single transmission line. GTE Sylvania has spent significant time and effort in solving both the basic problems in the design of short burst communications systems for military use with unattended sensor alarm transmitters. The results obtained are directly applicable to the problem at hand.

7.7 MODULATION TYPE

Frequency modulation holds a clear advantage over the two basic alternatives, AM and PM, for the transmission of short burst data. Amplitude Modulation (AM) is unsuitable because of the requirements for Automatic Gain Control (AGC), which requires long setting times which are incompatible with burst systems, and the fact that a limiting system is immune to the high amplitude noise components which predominate on the power lines.

Phase Modulation (PM) has the same general noise immunity characteristics as FM, however, it suffers from degradation due to short term phase changes in the transmission path which are quite common on power transmission lines where various loads are continually being switched on and off the line. PM also requires coherent detection with its associated long lock-up time for the phase reference oscillator, unless differentially coherent modulation is used which is impractical at low bit rates. Our tests in the laboratory on short burst phase modulated signals at UHF have confirmed these conclusions.

Thus, GTE Sylvania proposes a PCM-FM system as having optimum characteristics for short transmission on a power line.

7.7 (Continued)

The remaining problem, that of rapid bit and frame synchronization are solved by the use of split phase codes. These code types have the advantage of providing bit sync information along with each bit in the form of a known transition occurring at the start of each bit time. Thus, bit synchronization can occur within 2 bits, as the required energy is immediately available at the beginning of the message and no pull-in is required. The penalty for this ability is a doubling of the required transmission bandwidth, which is of little consequence in this application. This bandwidth doubling was included in the initial calculations provided earlier.

Frame synchronization is readily obtained in a burst system as the initial squelch signal when the carrier is turned on provides the initial "start of message" signal. Following the squelch signal a short 5 to 7 bit frame sync sequence will suffice to synchronize the message. A code having good auto-correlation characteristics such as Barker Codes should be used. These short sequences may be used in conjunction with the squelch signal to provide excellent results with burst signals.

7.8 MUTUAL INTERFERENCE

The only known problem with the proposed system is mutual interference between simultaneous transmission of the time multiplexed signals. First, to insure receipt of a signal in a system which has no message receipt verification, redundant transmission will be used. The distress transmitter will be latched ON when activated and transmit each 3-5 seconds until reset when help arrives. Second, the problem of simultaneous transmission caused by 2 or more Power Line transmitters receiving the same distress message will be overcome by including a random delay of 10 to 100 msec in each Distress/Receiver/Power Line Transmitter combination. Thus, if the same distress message is received for relay by 2 or more DRx/PLTx units, it will be randomly time multiplexed onto the power line and not cause mutual interference.

7.9 CONCLUSIONS

A system has been described which will provide the desired communication link in a near optimum manner. A 44 bit distress message will be time multiplexed on to the power line system. The message length will be 10 msec and be transmitted at near a 5K bit rate in a 10 KHz bandwidth using frequency modulation with a split phase pulse code modulation format. This system will provide excellent performance in a high noise environment and use redundant transmission to insure message reception without duplex transmission.

END