

TECHNICAL MEMORANDUM No. 10

April, 1974

SIFTER: AN EXPERIMENTAL COMPUTERIZED FINGERPRINT
TECHNICAL SEARCH SYSTEM FOR
STATE IDENTIFICATION BUREAUS

PROJECT SEARCH

State Identification Bureau

Project Committee

16290 Dup.

PROJECT SEARCH

Technical Memorandum No. 10
April 1974

SIFTER: AN EXPERIMENTAL COMPUTERIZED
FINGERPRINT TECHNICAL SEARCH
SYSTEM FOR STATE IDENTIFICATION
BUREAUS

Prepared under Grant No. 73-SS-99-3301 from the Law
Enforcement Assistance Administration, Department of
Justice.

Points of view or opinions stated in this document are
those of Project SEARCH and do not necessarily represent
the official position or policies of the Department of
Justice.

Submitted by the
Project SEARCH State Identification Bureau
Committee
Gary D. McAlvey, Chairman
Gregory L. Campbell, Technical Coordinator

SEARCH Project Group

Chairman

O. J. Hawkins
California

Vice Chairman

John R. Plants
Michigan

Members

Robert Davis
Alabama

James P. Wellington
Alaska

Robert J. Edgren
Arizona

Charles C. McCarty
Arkansas

O. J. Hawkins
California

Jon R. Ilk
Colorado

Harold R. Sterrett
Connecticut

Fred Johns
Florida

Ed Sills
Georgia

Lester Earl Cingcade
Hawaii

John Bender
Idaho

Gary McAlvey
Illinois

James Kinder
Indiana

Marvin R. Selden, Jr.
Iowa

James T. McDonald
Kansas

Charles L. Owen
Kentucky

Eugene Freeman
Louisiana

Richard C. Jones
Maine

James R. Donovan
Maryland

Andrew Klein
Massachusetts

John R. Plants
Michigan

Robert E. Crew, Jr.
Minnesota

Noah L. Mitchell
Mississippi

Robert J. Bradley
Missouri

Laurence L. Lytle
Montana

John H. Ayers
Nebraska

Ron Stroup
Nevada

Paul Hartigan
New Hampshire

Ronald E. Ayres
New Jersey

David Kingsbury
New Mexico

Archibald R. Murray
New York

Howard Livingston
North Carolina

Richard S. Hilde
North Dakota

Alphonso C. Montgomery
Ohio

John Robertson
Oklahoma

Gerald C. Schmitz
Oregon

E. Drexel Godfrey, Jr.
Pennsylvania

Lady Alfonso de Cumpiano
San Juan (Puerto Rico)

John J. Kilduff
Rhode Island

Carl B. Stokes
South Carolina

Harry Martens
South Dakota

William Thompson
Tennessee

Jerry Clay
Texas

Michael R. Stewart
Utah

Edward M. Prescott
Vermont

Richard N. Harris
Virginia

Emory W. Reisinger II
Virgin Islands

James N. O'Connor
Washington

Herbert F. Miller, Jr.
Washington, D.C.

Oscar S. Neely
West Virginia

Dennis A. Katter
Wisconsin

Rodrick Janney
Wyoming

Larry Polansky
Pennsylvania

Hubert M. Clements
South Carolina

LEAA Appointees

Thomas J. Stovall, Jr.
Texas

Sanger B. Powers
Wisconsin

TABLE OF CONTENTS

| <u>Section</u> | <u>Page</u> |
|---------------------|--|
| 1 | EXECUTIVE SUMMARY 1-1 |
| | Introduction 1-1 |
| | Statement of the Problem 1-3 |
| | Technical Approach 1-3 |
| | System Test 1-4 |
| 2 | SIFTER SYSTEM DESIGN 2-1 |
| | Principle of Operation 2-1 |
| | The Optimal Scoring System 2-3 |
| | Score Calculation 2-4 |
| | Computer Program Design 2-10 |
| 3 | TEST PROCEDURES AND RESULTS 3-1 |
| | Data 3-1 |
| | Test Procedures 3-2 |
| | Test Results 3-3 |
| | Comparison with SEARCH Technical Report No. 8 3-6 |
| | Further Development and Implementation . . 3-9 |
| <u>Appendix</u> | |
| A | THEORETICAL BASIS FOR SIFTER A-1 |
| B | SIFTER PROGRAM SPECIFICATIONS AND COMPLETE TEST RESULTS B-1 |

Section 1
EXECUTIVE SUMMARY

INTRODUCTION

This document reports on an experimental fingerprint technical search system, SIFTER¹, developed and tested by the Project SEARCH Committee on State Identification Bureaus and the staff of that committee.

Project SEARCH is a cooperative effort of the criminal justice systems of the 50 states, banded together to improve the criminal justice system of the United States through the application of appropriate technology. The work reported in this document, as well as other efforts of Project SEARCH, was funded by a grant from the Law Enforcement Assistance Administration of the U.S. Department of Justice.

The members of the State Identification Bureau Project Committee are shown in Exhibit 1-1. Gary D. McAlvey served as chairman of the Project Committee.

Administrative services were provided by the California Crime Technological Research Foundation under the direction of Douglas E. Roudabush, Executive Director. David G. Yamada provided staff support.

Technical staff services for the project were provided by Public Systems Incorporated, under the direction of Paul K. Wormeli, SEARCH Project Coordinator. Gregory L. Campbell acted as principal investigator for the project. Lyn Taynai wrote and documented the software and Dr. Ernest Unwin and Steven Patent provided technical assistance and consultation.

¹System for the Identification of Fingerprints by Technical Search of Encoded Records.

Project SEARCH
State Identification Bureau
Project Committee

Chairman

Gary D. McAlvey
Department of Law Enforcement, Illinois

Members

Donald L. Baker
Department of Justice
California

Howard G. Bjorklund
Department of Justice
Wisconsin

Glenn W. Dafoe
Michigan State Police

Charles Davis
Florida Department of Law
Enforcement

George J. Fagan
Connecticut State Police

William Freele
Oregon State Police

John M. Jones
Federal Bureau of
Investigation
Washington, D.C.

Stan Kimball
Department of Public Safety
Arizona

LEAA
Representative

Ronald C. Allen
Washington, D.C.

Administrative
Staff

David G. Yamada
California Crime
Technological
Research Foundation
Sacramento, California

Technical
Staff

Donald W. Ostrander
Gregory L. Campbell
Public Systems inc.
Sunnyvale, California

Paul D. McCann
New York Division of Criminal
Justice Services

James L. Neighbours
Arkansas Department of Public
Safety

Vincent Peterson
New Jersey Division of State Police

Robert Ragland
Virginia Department of State Police

Ivard R. Rogers
Utah Department of Public Safety

Paul Schultz
Washington State Patrol

Carl B. Stokes
South Carolina Law Enforcement
Council

Joel Tisdale
Texas Department of Public Safety

STATEMENT OF THE PROBLEM

Previous to the work reported here, the State Identification Bureau Committee conducted research on the use of the NCIC classification in a computerized technical search system. This research is described in Project SEARCH Technical Report No. 8, "Design of a Model State Identification Bureau."

The NCIC classification system, because of its use in national criminal history files and its use of standard FBI and Henry code definitions, was hoped to be useful in a computerized search system. From experimental work, the Committee found that the system had sufficient selectivity for effective use; i.e., power to sort codes; but lacked sufficient reliability; i.e., ability to correctly select a matching record if one exists in a fingerprint file. These reliability and selectivity results were derived using a simple search procedure in which codes on each finger were required to match within a certain fixed tolerance. Such a technique was found to be simply too sensitive to differences in codes commonly made on different impressions of the same person's fingerprints.

To overcome these sensitivity problems and improve reliability and selectivity of the NCIC system, the research reported here was conducted. The committee believes that the SIFTER system presented here shows considerable promise in eventually being used as a computerized technical search system in state identification bureaus. It is recognized, however, that the system is experimental and that further development and refinement must be accomplished before it is implemented.

TECHNICAL APPROACH

The SIFTER fingerprint technical search system is designed to derive the maximum searching effectiveness from the information

contained in a fingerprint classification. SIFTER uses the NCIC classification system which requires manual encoding of fingerprint patterns by skilled technicians. However, the basic approach is general and can be adapted to any classification system including those involving automatic encoding.

SIFTER works by comparing each inquiry code with each file entry to derive a score which is proportional to the probability that the two classifications represent the same person. A threshold is set so that file entries with matching scores above the threshold are accepted as possible matches (candidates) and those below the threshold are rejected.

Probability tables for use in SIFTER are constructed from pairs of classifications taken at different times but known to be from the same person. Other tables are made from the observed distributions of pattern types found in a large fingerprint file. In using these data, the system adapts in an optimal way to the characteristics of the NCIC classification system.

SYSTEM TEST

Computer programs for the SIFTER system were written and tested using data provided by the members of the Identification Bureau Committee. The test data consisted of a library file of 10,000 NCIC code records provided by the State of Florida, a test set of 240 pairs of classifications taken by different technicians in twelve of the states represented on the committee, and a test set of 384 pairs of classifications supplied by the State of Florida. From each of the test sets, 100 cards were randomly selected for use as test inquiry codes. The remaining cards, 140 and 284 cards respectively, were used to build the required

probability tables, essentially to adjust the system parameters in preparation for the test.

The SIFTER test results are summarized in Exhibit 1-2, which indicates the reliability and selectivity of the system using NCIC classification, sex, and year of birth ± 5 as discriminators. The system has a reliability of .96, meaning that 96% of the potential matches in a file will be correctly identified as candidates. The system selectivity, i.e., the average proportion of the file that will be retrieved as candidates, was found to be 10.6×10^{-6} . In other words, for a file of one million individuals, an average of 10.6 candidates will be retrieved for each search of the file.

This performance compares quite favorably to that achieved by the technical search system as reported in SEARCH Technical Report No. 8. Using that system, with NCIC classification, sex, and year of birth ± 5 , the reliability was found to be only .865 while retrieving 10 candidates out of a file of one million records.

Exhibit 1-2: SIFTER Selectivity and Reliability
With NCIC Classification, Sex and Year of Birth \pm 5

| Data Element | Selectivity | Reliability |
|------------------------|-----------------------|-------------|
| Sex* | .746 | .999 |
| Year of Birth \pm 5* | .289 | .99 |
| NCIC Classification | 49×10^{-6} | .97 |
| Total | 10.6×10^{-6} | .96 |

*These data were obtained from Project SEARCH Technical Report No. 8.

Section 2

SIFTER SYSTEM DESIGN

The SIFTER¹ fingerprint technical search system is designed to derive the maximum searching effectiveness from the information contained in a fingerprint classification. SIFTER uses the NCIC classification system which requires manual encoding of fingerprint patterns by skilled technicians. (A complete listing of NCIC notation is presented in Exhibit 2-1.) However, the basic approach can be adapted to any classification system including those involving automatic encoding.

In this section, the operation of SIFTER is explained in non-technical terms, primarily through examples. The mathematical derivations, assumptions, and approximations involved in SIFTER are described in detail in Appendix A. The material in the appendix is not required to understand the system but may be of interest to the more mathematically oriented reader.

A brief description of the computer programs written for SIFTER is also contained in this section. Appendix B presents detailed computer program documentation as well as complete listings of test data and test results.

PRINCIPLE OF OPERATION

As with any fingerprint searching system, SIFTER requires a library file of classifications of previous offenders and classifications of inquiry cards to be searched against the file. SIFTER works by comparing each inquiry code with each file entry to derive a score which is proportional to the probability that

¹System for the Identification of Fingerprints by Technical Search of Encoded Records.

| Finger | Number | Finger | Number |
|---|--------|-------------|--------|
| Right Thumb | 1 | Left Thumb | 6 |
| Right Index | 2 | Left Index | 7 |
| Right Middle | 3 | Left Middle | 8 |
| Right Ring | 4 | Left Ring | 9 |
| Right Little | 5 | Left Little | 10 |
| Plain Arch: AA Tented Arch: TT Ulnar Loop: 01-49 (Ridge Count) Radial Loop: 51-99 (Ridge Count + 50) Plain Whorl: inner PI meeting PM outer PO Central Pocket Loop: inner CI meeting CM outer CO Double Loop: inner DI meeting DM outer DO Accidental: inner XI meeting XM outer XO Amputation: XX Scarred: SR | | | |

Exhibit 2-1
NCIC Fingerprint Classification Notation

the two classifications represent the same person (matching probability score). A threshold is set so that file entries with matching scores above the threshold are accepted as possible matches (candidates) and those below the threshold are rejected.

SIFTER is similar to other searching systems in which a "closeness" score is calculated, the key difference being the significance of the score value. The SIFTER score provides an absolute determination of whether or not the file entry should be retained as a potential match. In operation, some inquiry prints will match several candidates while some will match none. The system thus provides a positive determination of a non-match. Scores associated with one inquiry argument can also be compared with those of all other inquiries since each score represents the same quantity, i.e., the probability of a match.

THE OPTIMAL SCORING SYSTEM

A reasonable objective of a technical search system is to maximize reliability (probability that a match will be found in the file if one exists) given a limit on the average number of candidates allowed per search. In other words, reliability is maximized under the constraint of fixed resources (i.e., the number of technicians available for candidate verification). Alternatively, an acceptable reliability may be established and the objective would be to minimize the average number of candidates and thereby minimize the number of technicians required for verification.

Under either of the above objectives, the selection of matching probability as a score and the setting of a score threshold value can be shown to be the optimal searching method for any classification system (See Appendix A).

In practice, developing a workable system based on such a score requires a number of approximations which may not be optimal and probably could be improved with further development.

SCORE CALCULATION

The matching probability score for SIFTER is calculated from data on differences in classification codes of multiple impressions of the same person's fingerprints, and from the distributions of classifications found in fingerprint files.¹

Discussion

To understand the calculation of the matching probability score, it is helpful to consider an intuitive rationale for its derivation.

One would expect that two fingerprint classifications that were identical or very similar would result from fingerprints of the same person. One might expect to find commonly occurring differences such as a small difference in ridge count on one or two fingers. However, one would not expect a rare difference such as a whorl mistaken for a plain arch. Consequently, if two classifications are compared and found to be the same or have only a few commonly occurring differences, it could be expected that these classifications might represent the same person. An uncommon error or a great number of common errors would tend to indicate that the codes were from different persons.

¹Experience with fingerprint classifications (Section 3-2 of SEARCH Technical Report No. 8) indicates that differences occur between the classifications of the same set of fingerprints by two technicians. For example, differences of one or two in ridge count on ulnar and radial loops are quite common. Some differences in pattern type such as plain arch versus tented arch and tented arch versus loop of low ridge count are also common. Usually, but not always, these differences can be eliminated by allowing referencing, i.e., allowing more than one classification of a questionable fingerprint pattern.

In addition to similarity of classifications, another factor contributes to the determination that two codes match. If the classifications are common so that many non-matching classifications are similar, then one would have less confidence that the pair matched than if they were more rarely occurring classifications. For example, in a file on one million NCIC classifications, there are approximately 1,600 entries with plain arches on all ten fingers. When comparing an inquiry card that contains all plain arches with one of these file entries, there is little chance of a match even though the classifications are identical. However, if the classification were quite rare, such as all whorls on one hand and all arches on the other, and a file entry were found to have the identical or close classification, then a match is highly likely.

The SIFTER matching score accounts for both of the above factors in a mathematically precise manner. Scores are calculated giving the proper emphasis on the types of differences produced by different technicians and different impressions of the same fingerprints. The "rareness" of each classification is also calculated using the distribution of fingerprint types found in a file.

Numerical Example

In order to further clarify and illustrate the score calculation, a simplified numerical example is presented.

For the purpose of illustration, assume that all fingerprint patterns are plain arches, tented arches, or ulnar loops with ridge counts of five or less. The possible codes, using NCIC notation are thus AA, TT, 01, 02, 03, 04, and 05. Also assume that a library file of classifications and several pairs of classifications known to be from the same person are available.

The first step toward score calculation is the construction of a classification pair matrix as shown in Exhibit 2-2.

The first part of the exhibit shows four pairs of classifications taken at different times but of the same person. For each pair, the top code is considered to be an inquiry, the bottom code to be a file entry. Part B of the exhibit shows the classification pair matrix as constructed using the four classification pairs. The matrix is simply a tally of code pairs found in the data. For example, there are ten AA-AA pairs; there are 2 AA-TT pairs where AA is the inquiry and TT is the file entry; there is one 02-TT pair where 02 is the inquiry and TT is the file entry.

The matching pair matrix is converted to probabilities, used in score calculation, by normalization as shown in Exhibit 2-2C. Each table entry is divided by the row total as indicated. The resulting values are the probabilities of obtaining a corresponding file code, given the specified inquiry code. These are conditional probabilities, and therefore the matrix rows add to one. In practice, the blank spaces in the normalized matching pair matrix would be filled by a small number, such as one over file size to prevent the calculation of zero scores.

The next basic step in preparation to calculate scores is to sort and count code entries in the library file. Assume that a file of 10,000 of these special codes is sorted as shown in Exhibit 2-3. The exhibit lists each unique sequence of codes and the number of those entries found in the file. For example, there are twelve file entries with a code value of "TT AA 04 05 05 TT AA AA 03 TT".

The last column in the exhibit shows the portion of the file represented by each code and is simply the count divided by 10,000. This last column is used in the score calculation and is a measure of the "rareness" of each file entry.

File Code

| | | | | | | | | |
|----|----|----|----|----|----|----|----|-------|
| | AA | TT | 01 | 02 | 03 | 04 | 05 | Total |
| AA | 10 | 2 | | | | | | 12 |
| TT | 1 | 6 | 1 | | | | | 8 |
| 01 | | 2 | | 1 | | | | 3 |
| 02 | | 1 | 1 | 3 | | | | 5 |
| 03 | | | | 1 | 3 | 1 | | 5 |
| 04 | | | | 1 | 1 | 1 | | 3 |
| 05 | | | | 1 | 1 | | 2 | 4 |
| | | | | | | | | 40 |

Inquiry Code

B. Tally of matching code pairs.

File Code

| | | | | | | | | |
|----|-----|-----|-----|-----|-----|-----|-----|-------|
| | AA | TT | 01 | 02 | 03 | 04 | 05 | Total |
| AA | .83 | .17 | | | | | | 1.0 |
| TT | .12 | .75 | .12 | | | | | 1.0 |
| 01 | | .67 | | .33 | | | | 1.0 |
| 02 | | .20 | .20 | .60 | | | | 1.0 |
| 03 | | | | .20 | .60 | .20 | | 1.0 |
| 04 | | | | .33 | .33 | .33 | | 1.0 |
| 05 | | | | .25 | .25 | | .50 | 1.0 |

Inquiry Code

C. Normalized classification pair matrix.

| | | | | | | | | | | | |
|---------------|----|----|----|----|----|----|----|----|----|----|----|
| Finger Number | 1 | 2 | 3 | 4 | 5 | 6 | 7 | 8 | 9 | 10 | |
| | AA | AA | AA | AA | 01 | 03 | TT | TT | 02 | 05 | 04 |
| | AA | AA | TT | 02 | 02 | TT | TT | TT | TT | 05 | 03 |
| | 05 | 01 | 03 | 03 | 02 | 05 | 02 | 04 | 03 | 04 | |
| | 05 | TT | 03 | 04 | 02 | 03 | 01 | 04 | 03 | 02 | |
| | TT | TT | 02 | 03 | 05 | TT | TT | TT | TT | 02 | 01 |
| | TT | 01 | 02 | 03 | 02 | TT | TT | TT | TT | 02 | TT |
| | AA | TT | AA | AA | AA | AA | TT | AA | AA | AA | AA |
| | AA | AA | AA | AA | AA | AA | AA | AA | AA | AA | AA |

A. Pairs of classification known to be from the same person.

| Classifications | | | | | | | | | | Number in File | Proportion of File |
|-----------------|----|----|----|----|----|----|----|----|----|-------------------|-----------------------|
| AA | AA | AA | AA | AA | AA | AA | AA | AA | AA | 232 | .0232 |
| AA | AA | AA | AA | AA | AA | AA | AA | AA | TT | 97 | .0097 |
| AA | AA | AA | AA | AA | AA | AA | AA | TT | AA | 125 | .0125 |
| AA | AA | AA | AA | AA | AA | AA | AA | TT | TT | 46 | .0046 |
| . | . | . | . | . | . | . | . | . | . | . | . |
| AA | AA | TT | TT | 02 | 03 | 03 | TT | TT | TT | 2 | .0002 |
| . | . | . | . | . | . | . | . | . | . | . | . |
| TT | AA | 04 | 05 | 05 | TT | AA | AA | 03 | TT | 12 | .0012 |
| . | . | . | . | . | . | . | . | . | . | . | . |
| 03 | 01 | 02 | 02 | 03 | 05 | 02 | 03 | 03 | 02 | 1 | .0001 |
| . | . | . | . | . | . | . | . | . | . | . | . |
| 05 | 05 | 05 | 05 | 05 | 05 | 05 | 05 | 05 | 04 | 2 | .0002 |
| 05 | 05 | 05 | 05 | 05 | 05 | 05 | 05 | 05 | 05 | 43 | .0043 |
| TOTAL | | | | | | | | | | 10,000 | 1.0 |

Exhibit 2-3. A file of 10,000 example codes sorted in ascending order. The sorting sequence is AA, TT, 01, 02, 03, 04, 05. The number of identical file entries in the file is indicated. (The numbers are fictitious. Many of the possible combinations of codes are not contained in a file of only 10,000 codes.)

To illustrate score calculation, two example inquiry codes are selected to be searched against the file:

1. AA AA AA AA AA AA AA AA AA AA
2. AA AA TT 01 03 01 05 TT TT TT

Each inquiry code is compared with each file entry to derive a score.

To compare inquiry #1 with the first file entry, each pair of codes corresponding to the same finger is used to look up a probability in the normalized code pair matrix. In this case, each comparison is AA versus AA or a value of .83 in the table. The ten resulting numbers are multiplied; i.e.,

$$.83 \times .83 \times .83 \times .83 \times .83 \times .83 \times .83 \times .83 \times .83 \times .83 = .155$$

and this number is divided by the proportion value corresponding to the file code, in this case .0232. The result for the score:

$$.155 / .0232 = 6.7$$

For another example, consider inquiry #2 compared to the fifth file entry shown in Exhibit 2-3. The probability values found in the matrix are:

$$.83 \times .83 \times .75 \times .67 \times .33 \times .60 \times .60 \times .75 \times .75 \times .75 = .0173$$

The score is then $.0173 / .0002 = 87$, where .0002 is the file proportion value. Notice that this score is higher than that for inquiry #1 because the classification is more uncommon. The score is higher even though the codes do not match exactly. (There is a 01-TT error in finger 4 and a 01-03 error in finger 6.) All other comparisons between inquiries and file entries can be calculated in a similar manner. Most comparisons result in extremely small scores indicating that they are not matches.

The score value itself, using this technique, is the relative increase or decrease in the probability that the selected inquiry and file entry match over the matching probability that

two randomly selected codes match. For example, a score of 87 means that inquiry #2 matches its corresponding file entry with a probability 87 times greater than the probability of matching a randomly selected entry.

COMPUTER PROGRAM DESIGN

The SIFTER system as written consists of three computer programs designed to calculate scores and conduct searches of inquiry NCIC codes against a file. The programs were all written for batch processing to minimize computer costs during the test runs. For operational use, an on-line version of the programs could be written. The functioning of each of these programs is described below. A much more detailed description is found in Appendix B.

SIFTER-NUMER Program

The first program, called SIFTER-NUMER, uses matching pairs of classifications to generate classification error probability tables. These are called numerator tables because the table values are used to calculate the numerator of a formula for matching probability. These tables are then passed to the search program. The raw numerator tables are smoothed and normalized (described in Appendix B) in the search program. In an operational system, these table manipulation functions would be incorporated into SIFTER-NUMER.

SIFTER-DENOM Program

This program calculates denominator tables for use in score calculation using the library file as data. Again, a normalization procedure is conducted which in an operational system would be incorporated into SIFTER-DENOM. The tables generated are passed to the next program.

SIFTER-SEARCH Program

SIFTER-SEARCH calculates scores for combinations of inquiry fingerprint cards, designated A, and file cards, designated B. It operates in two modes as shown in the simplified flowchart given in Exhibit 2-4.

In Mode 1, test inquiry codes are searched against a library file of 10,000 records to see how many candidates are found to exceed certain specified score threshold values. There are no true matches to the inquiry codes in the file. Therefore, all candidates found are non-matching; i.e., the score may be high, but the prints are not from the same person. This mode is used to measure the selectivity of the system as a function of threshold value.

As shown in the left branch of the flowchart corresponding to Mode 1, the threshold values and all of the inquiry codes are read into computer core. The program then reads file entries (from tape) one at a time and calculates scores for each of the inquiry codes before reading the next file entry. The denominator value is calculated once for each file entry immediately after it is read. Numerators are calculated for each inquiry A and the file entry B. Scores are calculated by the simple formula:

$$\text{SCORE} = \text{NUMERATOR} / \text{DENOMINATOR}$$

Each score value is then compared with the thresholds and tallies are made for each score that exceeds a threshold. When the end of the library file is reached, the inquiry codes and their corresponding tallies are printed. Some example outputs showing actual test runs are contained in Appendix B.

Mode 2 is used to calculate scores for pairs of NCIC codes that are known to be from the same person. These scores are then compared with the threshold values used in Mode 1 to determine the system's reliability (its probability of selecting a true match if one exists in the file) as a function of threshold value.

In mode 2, a pair of fingerprint cards is read. A is denoted the inquiry print and B the file print. NUMER, DENOM, and SCORE are simply calculated and printed as shown in the flowchart.

The test procedures and results for the SIFTER programs are presented in the next section.

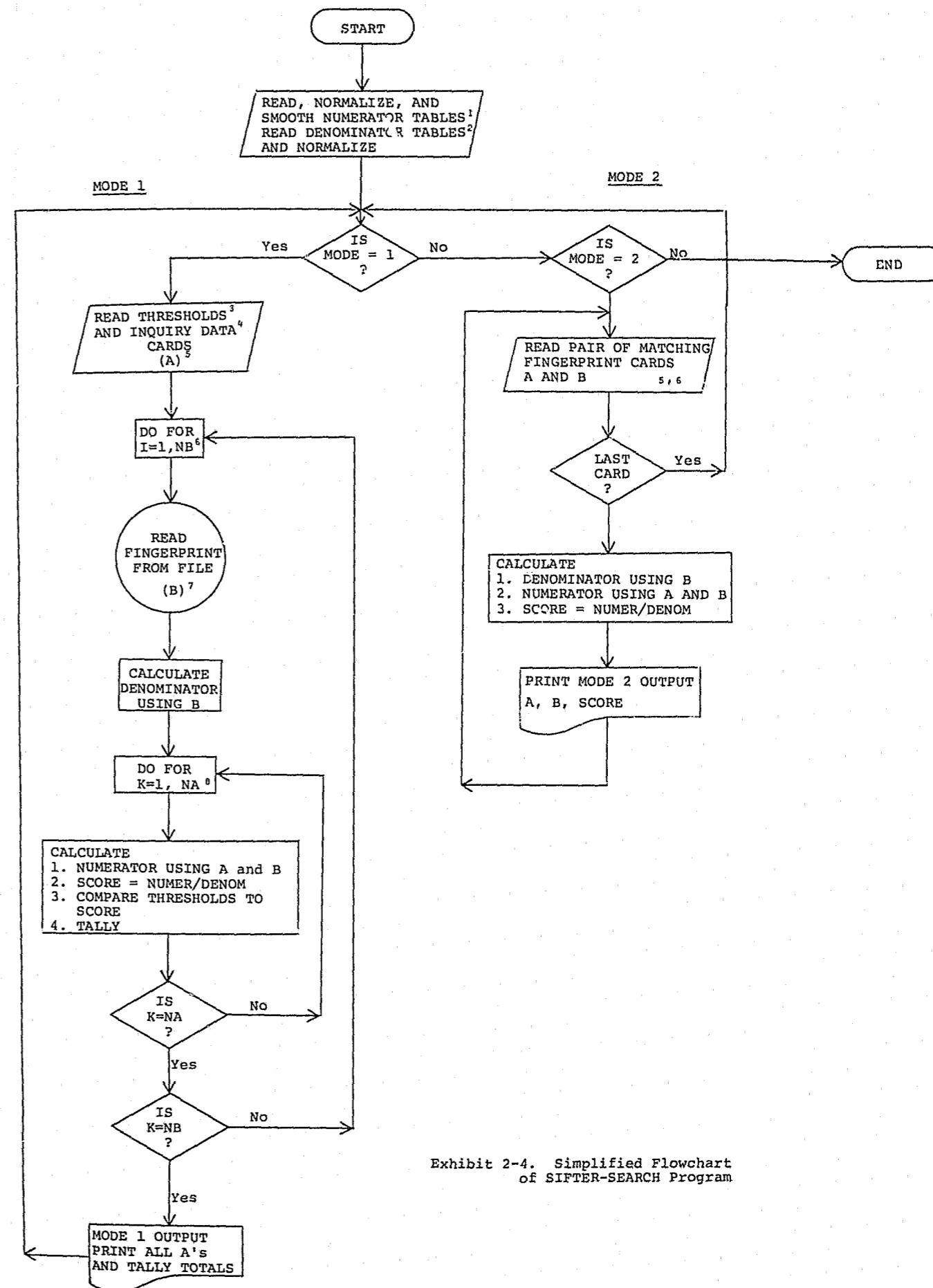

Exhibit 2-4. Simplified Flowchart of SIFTER-SEARCH Program

Section 3

TEST PROCEDURES AND RESULTS

The SIFTER computer programs, described in the previous section, and in more detail in Appendix B, were written in Fortran IV language and tested on an IBM 370-155 computer. This section describes the data and procedures used in the test and presents the test results. The chapter is concluded with a discussion of further development and implementation of SIFTER.

DATA

Test data were obtained from states represented on the Project SEARCH State Identification Bureau Committee. Three groups of data were used:

- A file of 270,000 NCIC records was available from the State of Florida for use in SEARCH Technical Report No. 8, "The Design of a Model State Identification Bureau."
- A set of 240 pairs of NCIC classifications (produced by two technicians classifying the same cards) were prepared by identification bureaus represented on the committee for use in Technical Report No. 8.
- The State of Florida also prepared a set of 384 classification pairs by having technicians classify cards identified on name search and then recording the new code together with the previously derived code as it appeared in the file.

For the test, 10,000 of the Florida NCIC records were randomly selected from the complete file of 270,000 for use as a library data base. Of the 240 card set, 100 were selected as test inquiry cards (referred to as inquiry set #1) while the remaining 140 cards were used to generate error probability tables used by SIFTER. Similarly, the 384 Florida classification pairs were divided into a test set of 100 (inquiry set #2) and a table generating set of 284 classification pairs. The

table generating sets are equivalent to "tuning sets" which establish system parameters and, therefore, should be separate from the test cards to insure unbiased results.

TEST PROCEDURES

Tests of the SIFTER programs were conducted to measure the system's selectivity (the average proportion of a file returned as candidates to an inquiry) and reliability (the probability of correctly selecting the matching candidate if a match is present in the file).

To perform the test, the program SIFTER-NUMER was used to generate two sets of numerator tables from the 140 card and the 284 card tuning sets. SIFTER-DENOM was run to generate denominator tables from the library file of 10,000 codes. These tables were then used by SIFTER-SEARCH which searched the inquiry code data sets against the file.

The search program actually operated in two modes. In Mode 1, the inquiry codes were searched against the file to find the number of candidates exceeding given threshold values. In Mode 2, the inquiry codes were compared with the codes known to be from the same person. The scores of these matching pairs were then compared with the file search scores to find the number of true matches and the average number of non-matching candidates to be anticipated for each setting of the threshold.

In the search test, Henry Primary was used as an initial discriminator. This corresponds to segmenting the file by Henry Primary and searching only in the appropriate pocket. To reduce possible misses due to errors in the primary, references involving whorl/non-whorl decisions were allowed. In addition, scars and amputations automatically caused referencing of the primary.

TEST RESULTS

The test results of SIFTER are shown in Exhibit 3-1, which displays the system's reliability and selectivity as a function of threshold value. Results for inquiry sets #1 and #2 are shown separately. In the exhibits, reliability is expressed as the proportion of the inquiries that matched their code pairs with scores above the thresholds shown. Selectivity is expressed as the number of non-matching candidates retrieved from the 10,000 card file, averaged over the 100 inquiries. These figures can be converted to selectivity by multiplying by 10^{-4} .

The last column in the exhibit shows an estimate of non-matching candidates obtained with referencing of the Henry Primary, which sometimes requires searching in more than one Henry pocket. The test results on reliability include errors in Henry Primary. (There were two such errors in inquiry set #2.)

The threshold scores in the exhibit represent the relative increase in the matching probability of the inquiry and file entry over that of two randomly chosen classifications. For example, a score of 10^3 , or 1,000, means that the probability that the inquiry and file entry match is 1,000 times greater than if they were chosen at random.

To calculate the average number of candidates which would be returned for an inquiry, the expected number of matching candidates must be added to the average number of non-matching candidates as shown in the exhibit. For example, refer to the data on inquiry set #1, which shows a reliability of .97 with an average of .49 non-matching candidates returned from a file of 10,000. If an inquiry is known to match a file entry, then the

| INQUIRY SET #1 | | | Average Non-Matching Candidates ¹ | |
|-------------------------|------|-------------|--|------------------------|
| Threshold ² | Hits | Reliability | Test Results | With Henry Referencing |
| 1 x 10 ³ | 85 | .85 | .13 | .14 |
| 3.1 x 10 ² | 90 | .90 | .18 | .20 |
| 1 x 10 ² | 93 | .93 | .30 | .33 |
| 3.1 x 10 ¹ | 97 | .97 | .44 | .49 |
| 1 x 10 ¹ | 99 | .99 | .89 | .98 |
| total inquiry cards 100 | | | | |

| INQUIRY SET #2 | | | Average Non-Matching Candidates ¹ | |
|-------------------------|------|-------------|--|------------------------|
| Threshold | Hits | Reliability | Test Results | With Henry Referencing |
| 1 x 10 ³ | 76 | .76 | .55 | .75 |
| 3.1 x 10 ² | 78 | .78 | .84 | 1.14 |
| 1 x 10 ² | 80 | .80 | 1.20 | 1.63 |
| 3.1 x 10 ¹ | 84 | .84 | 1.98 | 2.69 |
| 1 x 10 ¹ | 89 | .89 | 3.04 | 4.13 |
| 3.1 | 95 | .95 | 4.58 | 6.23 |
| total inquiry cards 100 | | | | |

¹Retrieved from file of ten thousand records.

²The threshold values are equally spaced logarithmically.

Exhibit 3-1. Test Results of SIFTER Program

one true match will be returned along with the non-matching candidates for an average of 1.49 candidates. In general, the expected number of candidates is the technical search hit rate (about .05 for typical state bureaus) plus the average non-matching candidates, or $.05 + .49 = .54$ for the above example. The average number of non-matching candidates is directly proportional to the file size; therefore, it can be projected to files larger than 10,000. If the file were 100,000, the average number of candidates would be $.05 + 4.9 = 4.95$. With larger files, additional data elements, such as sex and year of birth, can be added to the NCIC code to reduce the number of candidates.

Two trends can be noted from Exhibit 3-1. First, as the threshold levels are lowered, both the number of true matches and the number of non-matching candidates increase. Second, the results from inquiry set #2 are considerably worse than those from set #1. In order to achieve the same reliability, approximately 20 times the number of non-matching candidates must be accepted for set #2 compared to set #1.

Recall that set #1 was produced by different technicians classifying identical cards, while set #2 was produced from different impressions of criminal prints taken at widely different times. Test set #2 may, therefore, more accurately represent the expected results of an operational system. However, the file from which test set #2 was obtained was not originally meant to be used for fingerprint searching, but was simply a required data element for the NCIC Computerized Criminal History System. Therefore, the quality control may have been less strict than required by this type of system.

COMPARISON WITH SEARCH TECHNICAL REPORT NO. 8

At this point, it is interesting to compare the results of SIFTER with those attainable with the direct matching technique designed in Technical Report No. 8. That technique involves two steps:

- The pattern type and tracing of the file record must be exactly the same as that of the entry record (or of references in the entry record), and ridge counts of the file record must be within three of the corresponding ridge counts on the entry record. Any file record not meeting all of these criteria simultaneously is rejected from further consideration.
- File records surviving this first test are given a final test on the basis of ridge count. The "error" in ridge count for each appropriate finger of the file card and input card is calculated and these errors are summed to produce a total error. Three is subtracted from the total error to produce an adjusted total error. This figure is divided by the number of ridge-countable fingers to produce an average adjusted error. If the average adjusted error exceeds 1, the file record is rejected from further consideration.

The results of the direct matching technique as applied to inquiry sets #1 and #2 are shown in Exhibit 3-2, which tabulates reliability and selectivity as a function of the amount of referencing allowed. For data set #1, references on both inquiry and file cards were available. The highest reliability, 83%, is achieved using both sets of references.

Using inquiry set #1 as a basis, SIFTER produces a reliability of 97% with about the same number of non-matching candidates that result from an 83% reliability using the direct match technique.

To judge the results more easily, the test results are shown graphically in Exhibit 3-3. Again, the superiority of SIFTER is demonstrated for test set #1. The results of test set #2

INQUIRY SET #1

| | Hits | Reliability | Average Non-Matching Candidates* |
|----------------------------|------|-------------|----------------------------------|
| No Referencing | 57 | .57 | .087 |
| Referencing Inquiry | 76 | .76 | .20 |
| Reference Inquiry and File | 83 | .83 | .46 |
| total inquiry cards | 100 | | |

INQUIRY SET #2

| | Hits | Reliability | Average Non-Matching Candidates* |
|---------------------|------|-------------|----------------------------------|
| No Referencing | 49 | .49 | .087 |
| Reference Inquiry | 67 | .67 | .20 |
| total inquiry cards | 100 | | |

*Retrieved from a file of ten thousand records

Exhibit 3-2. Results Using Direct Matching Technique with References (the system described in SEARCH Technical Report No. 8)

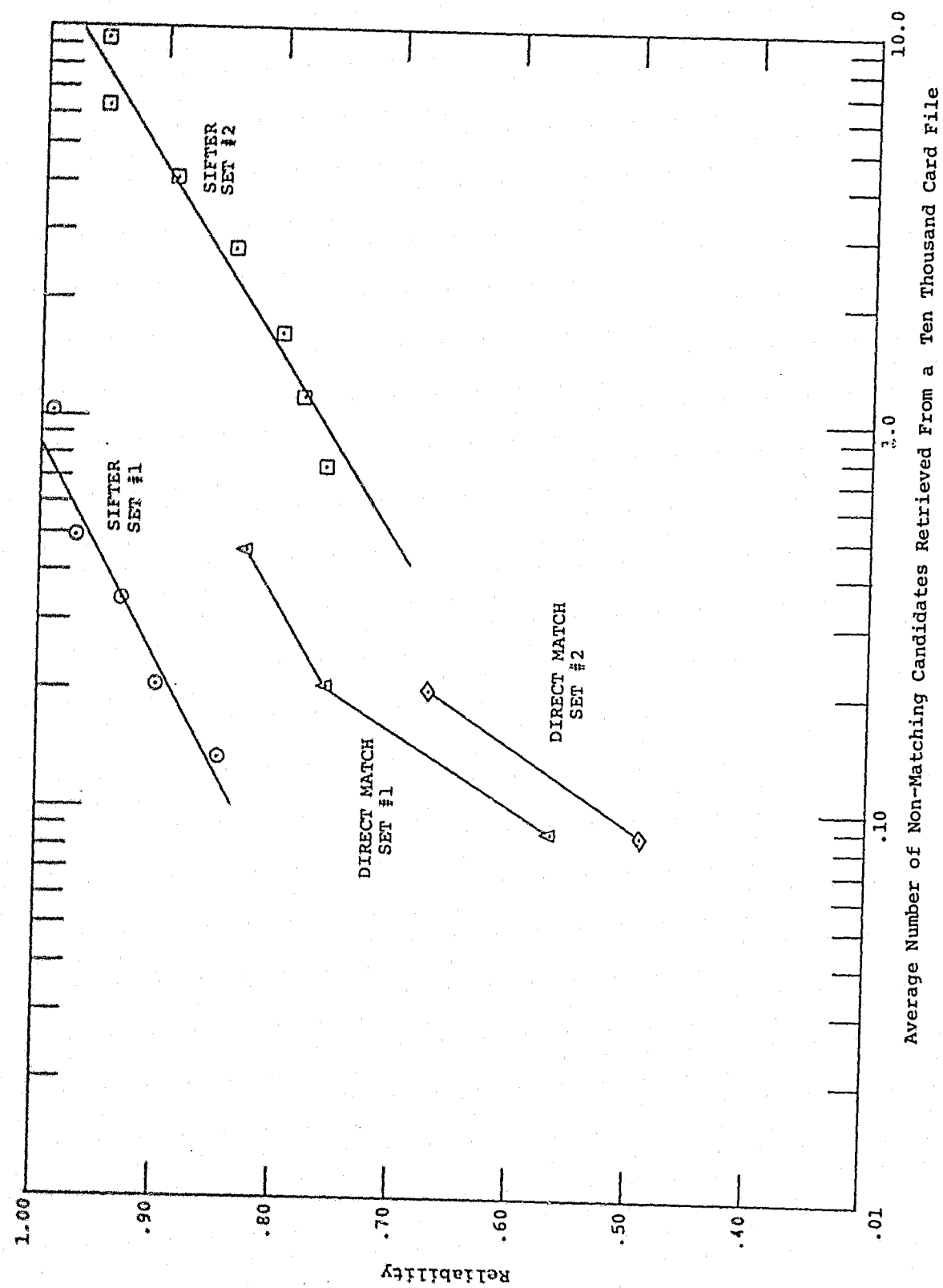

Exhibit 3-3. Graphical Display of SIFTER Test Results

are more difficult to interpret since the highest reliability resulting from the direct match technique is only 67%. SIFTER at least allows much higher reliabilities to be attained.

In states with large fingerprint files, it may be necessary to add some data elements to the technical search system to increase its selectivity. Exhibit 3-4 shows the effect of adding sex and year of birth ± 5 as additional discriminators.¹ With this system, a technical search reliability of .96 can be achieved by manually verifying about 10.6 candidates out of a file of one million records.

This performance compares quite favorably to that achieved by the technical search system as reported in SEARCH Technical Report No. 8. Using that system, with NCIC classification, sex, and year of birth ± 5 , the reliability was found to be only .865 while allowing 10 candidates out of a file of one million.

FURTHER DEVELOPMENT AND IMPLEMENTATION

The purpose of this report has been to describe an experimental computerized fingerprint technical search system and to present some results of tests, using data prepared by state identification bureaus. The test results as summarized in Exhibit 3-4 are quite encouraging and strongly suggest that states that are implementing the NCIC computerized criminal history system, which requires the NCIC fingerprint classifications as a data element, consider using these classifications for automated technical search. Also because of the superior performance of the SIFTER approach over that of the simple direct matching search technique, it would be reasonable to implement some version of the SIFTER system.

¹Reliability and selectivity data for these elements were obtained from Project SEARCH Technical Report No. 8.

Exhibit 3-4: SIFTER Selectivity and Reliability
With NCIC Classification, Sex, and Year of Birth \pm 5

| Data Element | Selectivity | Reliability |
|------------------------|-----------------------|-------------|
| Sex* | .746 | .999 |
| Year of Birth \pm 5* | .289 | .99 |
| NCIC Classification | 49×10^{-6} | .97 |
| Total | 10.6×10^{-6} | .96 |

*These data were obtained from Project SEARCH
Technical Report No. 8.

Before implementation, however, a number of additional tasks should be accomplished. Any state interested in implementation should conduct further testing of the system with their own data to see if the system meets their requirements. Since the number of candidates retrieved on a search is proportional to the file size, states with large files (over one million) may find the system to be inadequate. Since SIFTER already maximizes the effectiveness of the classification system, the only way to significantly improve performance is to carry the fingerprint classification to more detail than that contained in NCIC. Deciding what further classifications to add should be a fairly major undertaking. Care should be exercised to choose the characteristics that provide the greatest additional selectivity while maintaining high reliability. If the classification system is changed, probability tables used by SIFTER must be modified and expanded to accommodate the changes.

Whether or not changes are made in the coding system, the next required task is to design an operational version of SIFTER. The design should be tailored to the computing equipment and procedures presently used in the implementing state identification bureau. The interface with name search systems and computerized criminal histories should be considered. Also some provision must be made for retrieving candidate fingerprint cards either by refiling them by an identifying number or by entering the file cards on an image retrieval system such as microfilm or videofile.

The design itself should provide for rapid and economical search of inquiry cards. Either a batch or on-line system could be designed, the on-line system being somewhat more costly but providing the speed consistent with rapid response by the bureau. The design must also specify the required files, computer programs, and procedures for operation and file maintenance.

Upon completion of the design, the implementation phase can start. The system software should be written, whatever required equipment should be purchased, and file conversion should begin. The system should then be thoroughly tested and operated in parallel with the existing system until it is satisfactorily proven. When file conversion is complete, the new system would replace the old.

APPENDIX A

THEORETICAL BASIS FOR SIFTER

This appendix provides a complete mathematical justification of the fingerprint search technique described in this report. It is hoped that the general nature of the technique will be demonstrated so that a future user could adapt the methodology to coding systems other than NCIC. In fact, the technique can be applied to any search system in which a coding system is used to identify entries in a file; hence, the technique is not even restricted to fingerprints. Many of the same concepts presented here are also discussed in papers on name search systems¹.

The following discussion uses elementary concepts of probability theory, particularly conditional probability. While an attempt is made to include all required concepts and definitions, some knowledge of probability is required by the reader.

DEFINITIONS

The following key words and mathematical symbols are defined for use later in the appendix:

Population

The group of persons whose fingerprints may be taken and submitted to a fingerprint filing and searching agency, e.g., a state identification bureau. For a state bureau, the population would be those citizens of the state and visitors who might be arrested

¹See "Name Search Techniques" Project SEARCH Special Report No. 1, December 1970, and Newcombe, Howard B., "Record Linking: Design of Efficient Systems for Linking Records into Individual and Family Histories" American Journal of Human Genetics, Vol. 19, No. 3, Part I (May), 1967.

for a fingerprintable offense or who might apply for a job or permit which requires fingerprint submission.

Fingerprint Classification

An alphanumeric code representing the patterns of fingerprints as they appear on fingerprint cards submitted to the identification bureau. The NCIC fingerprint codes are shown in Exhibit 2-1, in Section 2 of this report.

Fingerprint Code File

A collection of fingerprint classifications, each of a different person, previously submitted to the bureau.

Inquiry Codes

Classifications of fingerprint cards to be searched against the file. In practice, inquiries which are identified by name would not be searched against the fingerprint code file.

Event

A term used in probability to designate the occurrence of something of interest. Usually a letter is used to represent an event. For example, event A may be the random selection of a record from the fingerprint file which happens to have a code value of "17 TT 11 13 12 PI 56 08 CM 11".

P(A)

The probability that event A will occur.

P(AB) or P(A·B)

The probability that both event A and event B will occur.

P(A|B)

The probability that event A will occur given that event B is known to have occurred. This is a conditional probability; i.e., the probability that event A will occur is conditioned by the occurrence of event B. Mathematically, this conditional probability is defined as

$$P(A|B) = \frac{P(AB)}{P(B)}$$

where P(B) is not equal to zero.

Bayes' Theorem

A simple probability theorem used to derive the equation for the score value later in this section. Using the above notation, Bayes' Theorem can be written as

$$P(A|B) = \frac{P(B|A) \cdot P(A)}{P(B)}$$

MATCHING PROBABILITY CALCULATION

Using the above definitions and Bayes' Theorem, the probability that two given fingerprint classifications come from the same person can be calculated.

Two assumptions are made in this calculation. First, entries in the file are assumed to be independent, which would be true if each entry were randomly selected from the entire population (allowing for replacement in the population of the entry selected each time). However, duplicate file entries (i.e., for the same person) are not allowed, so a small amount of dependence is really present. Time did not permit study of the effect of this dependence on the system.

The second assumption is that inquiries are chosen independently of file entries. This assumption does not require each person in the population to be equally likely to be fingerprinted, only that the selection of one person is independent of the selection of all previous inquiries which have, in effect, become the file.

To derive the matching probability, three statistical events are considered. Let event I_{C1} be the submission of an inquiry card whose classification has the particular value $C1$, where $C1$ is one of the possible NCIC codes for a set of 10 fingers. Let event F_{C2} be the selection of a file entry which has another classification, $C2$, which may or may not be the same as $C1$. Let M be the event that the inquiry and the file entry represent the same person.

The desired matching probability is $P(M|I_{C1} \cdot F_{C2})$ or the probability of event M given events I_{C1} and F_{C2} . In other words, $P(M|I_{C1} \cdot F_{C2})$ is the probability that the inquiry and the file entry match (are from the same person) given that the inquiry code is $C1$ and the file code is $C2$.

From Bayes' Theorem, the matching probability can be calculated as

$$P(M|I_{C1} \cdot F_{C2}) = \frac{P(I_{C1} \cdot F_{C2}|M) \cdot P(M)}{P(I_{C1} \cdot F_{C2})} \quad (1)$$

where $P(I_{C1} \cdot F_{C2}|M)$ is the probability that the inquiry and file codes have values $C1$ and $C2$ respectively, given that they are from the same person's fingerprints; where $P(M)$ is the probability that the inquiry and file entry match without knowing the classifications; and where $P(I_{C1} \cdot F_{C2})$ is simply the probability that

an arbitrary inquiry and file entry have codes $C1$ and $C2$. $P(M)$ is called the a priori probability of a match. It is simply the probability that any two randomly chosen inquiry codes match.

The formula for matching probability can be simplified by making use of the independence assumptions. Since the inquiry and file entry are independent, the denominator of equation (1) can be written

$$P(I_{C1} \cdot F_{C2}) = P(I_{C1}) \cdot P(F_{C2}) \quad (2)$$

Using the definition of conditional probability, the numerator of equation (1) can be rewritten as

$$P(I_{C1} \cdot F_{C2}|M) \cdot P(M) = P(F_{C2}|I_{C1} \cdot M) \cdot P(I_{C1} \cdot M) \quad (3)$$

Also since the event, M , is not dependent on the inquiry code alone, $P(I_{C1} \cdot M)$ can be rewritten

$$P(I_{C1} \cdot M) = P(I_{C1}) \cdot P(M) \quad (4)$$

Using equations (2), (3), and (4), equation (1) can be simplified to

$$P(M|I_{C1} \cdot F_{C2}) = \frac{P(F_{C2}|I_{C1} \cdot M) \cdot P(M)}{P(F_{C2})} \quad (5)$$

which is the form used in SIFTER.

The term $P(F_{C2}|I_{C1} \cdot M)$ corresponds to the numerator tables as discussed in Section 2 and Appendix B. The expression is interpreted

as the probability that a file entry code has a value C2 given that the inquiry code is known to match and has a value C1. The term $P(F_{C2})$ is simply the probability distribution of the population of fingerprint codes and is the denominator discussed in Section 2 and Appendix B. The term $P(M)$ was defined previously.

OPTIMALITY

The use of matching probability as a score value can be shown to be optimal using the following line of reasoning:

Assume that an identification bureau has a file of N_F fingerprint records and an input volume of N_I inquiries during a time period (day, week, etc.). A total of $M=N_I \times N_F$ comparisons of inquiries versus file entries can therefore be made. Assume that the probability that each of these comparisons is a match has been calculated. Let these probabilities be numbered P_1 through P_M in the order of decreasing value; i.e., $P_j \leq P_i$ where $j>i$. If a certain number, say K , of these candidate comparisons are manually verified by fingerprint pattern comparison, then the expected number of hits over these K comparisons is simply

$$E_K(H) = \sum_{i=1}^K P_i \quad (5)$$

where the K candidates with highest matching probabilities are chosen as candidates. If the objective of the fingerprint search system is to maximize the expected number of hits for a given number of manual verifications, then the procedure of using matching probability as a score and selecting candidates with the highest scores is optimal. This can be proved by contradiction.

Assume that an alternative searching system exists that gives a higher expected number of hits than the above system. With the alternate system, K candidates are selected, some of which

may be different than those chosen previously. However, for each substitution, P_j for P_i , where $j>K$ and $i \leq K$, the hit probability is changed by $P_j - P_i$, which is either negative or zero since $P_i \geq P_j$ for $i < j$. Therefore, the expected number of hits cannot be raised by the alternate system and thus the superior system does not exist. This constitutes the proof.

It should be remembered that the above argument is based on the availability of the exact matching probability. In a practical system, with limited data and limited computer capability, approximations in calculating the probabilities must be made. These approximations are not necessarily optimal and probably could be improved.

NUMERATOR AND DENOMINATOR CALCULATIONS AND APPROXIMATIONS

Although fingerprint terminology was used in the previous parts of this section, none of the arguments depend on the specific nature of the classification code. However, in order to use the probability formula, equation 5, the numerator and denominator on the right-hand side of that equation must be calculated from data specific to the particular application, namely NCIC fingerprint codes.

Numerator Calculation

The NCIC classification system contains 116 distinct codes which may be used to classify each finger. With 10 fingers there are 116^{10} , or approximately 10^{20} , distinct codes for a set of 10 prints. Ideally, the SIFTER numerator, (the term $P(F_{C2} | I_{C1}^M)$) should be calculated using a probability matrix relating all possible file codes. Such a matrix would be 10^{20} by 10^{20} elements and contain 10^{40} probabilities. A matrix this size is far beyond the storage capabilities of the largest digital computers and is obviously impractical.

To reduce the matrix to a reasonable size, some assumptions are required. First, the differences in classifications are assumed to be independent of finger number (i.e., the same kinds of errors are made on each of the 10 fingers) and second, the errors on each finger of a set of 10 are assumed to be mutually independent (e.g., knowing that an AA-TT error was made on finger 2 does not tell anything about potential errors on other fingers). With these assumptions, the probability matrix can be reduced to the possible classifications on one finger, or a matrix of 116 X 116 elements. This matrix is still somewhat large for economical computer use, therefore large sections of the matrix which contain low probabilities were eliminated in the actual design of SIFTER as described in Appendix B.

The finger independence assumption is quite reasonable when dealing with differences in codes. It is reasonable to expect that differences are random occurrences and therefore codes will be independent of the finger being coded. However, if different technicians use distinctly different rules for classifying, then some definite dependence will be introduced. In the research for this report, time did not allow for statistical testing of this independence assumption.

The other term in the numerator, $P(M)$, is the probability that any two classifications taken from the population will match. This calculation is extremely difficult since it depends on a detailed understanding of the population. However, since the term is a constant for all inquiry versus file comparisons, it can be dropped without affecting the usefulness of the score values. Therefore, the term was not used in SIFTER. The score value in SIFTER thus represents the increase or decrease in matching probability over that of random selection. For example, a score of 100 means that the probability that the inquiry and file entry match is 100 times greater than if they were chosen at random.

Denominator Calculation

The calculation of the denominator, the term $P(F_{C2})$, is at the same time simpler and more complicated than the calculation of the numerator. It is simpler because only a one-dimensional list of 116^{10} probabilities is required. On the other hand, complications arise because codes of different fingers of the same set are definitely not independent. The number 116^{10} is still too large for computer storage. In addition, even with a large data base of 10,000 to one million records, the calculation of all those probabilities would be impossible since there are far more numbers to calculate than there are available data values.

No doubt, there are many ways to solve the above problem. The method used in SIFTER involves two steps which separate the calculation of pattern type distributions from that of ridge count distributions.

The distribution of pattern types and tracings was found by sorting the 10,000 record file, ignoring ridge counts; i.e., considering ulnar loops as a single category, and radial loops as another. The number of classifications with distinct sequences of pattern types and tracings were then counted. As a result of the sort and count, 582 out of 10,000 records were found to have all ulnar loops, 158 had radial loops in both index fingers and ulnar loops on all other fingers, 11 had plain arches in all 10 fingers, and 51 had a plain whorl with outer tracing on the right thumb and ulnar loops on the other fingers. Many of the more unusual combinations of patterns occurred in much smaller groups. In fact, 5,744 out of the 10,000 codes were unique; i.e., the group size was one.

The probability that a particular sequence of patterns would be found in the population was estimated to be the group count, as determined above, divided by the file size, 10,000. For example, the probability of selecting the sequence of all ulnar loops was estimated to be $582/10,000 = .0582$. This is a statistically valid method of producing an unbiased estimate of the proportion present in the parent population. The one problem with it is that the estimate is probably not very accurate for patterns in small groups, such as groups of one.

The second step in the denominator calculation involves some assumptions. The denominator tables in SIFTER take into account the interdependence of ridge counts on ulnar and radial loops. However, ridge counts must be assumed to be independent of non-loop patterns on other fingers in order to allow multiplication of the two separately calculated probabilities. The other assumption involves the nature of ridge count dependence and can best be explained through an example.

Consider a classification with all ulnar loops. After examining many such classifications, some trends can be found. For example, if one or two fingers have high ridge counts, then all the fingers are likely to have high ridge counts; similarly, if some are low, all tend to be low. Another general pattern is that counts on thumbs tend to be higher than the average for a set and index fingers tend to have counts lower than average.

To preserve these dependencies, the sequence of ridge counts must be considered as a whole. Let N_i be the ridge count on finger i , where i goes from 1 to 10. Then the desired probability distribution is $P(N_1 N_2 N_3 N_4 \dots N_{10})$ or the probability that the sequence $N_1 N_2 N_3 \dots N_{10}$ occurs in the population.

Using conditional probabilities, this can be expressed without any assumption as

$$P(N_1 N_2 \dots N_{10}) = P(N_1) \cdot P(N_2 | N_1) \cdot P(N_3 | N_1 N_2) \cdot \dots \cdot P(N_{10} | N_1 N_2 \dots N_9) \quad (6)$$

In other words, the distribution of ridge counts on each finger after the first is dependent on the ridge count on the previous fingers. This form, while exact, would require an extremely large number of probability tables.

In SIFTER, a first order approximation of equation (6) is used. The conditional probabilities in the right-hand side of the equation, which depend on the exact values of previous fingers, are approximated by probabilities dependent on the average count of the previous fingers. Mathematically, the conditional probabilities are approximated as

$$P(N_i | N_1 N_2 \dots N_{i-1}) = P(N_i | \left(\frac{1}{i-1} \sum_{j=1}^{i-1} N_j \right)) \quad i = 2, 3, \dots, 10 \quad (7)$$

Each conditional probability is reduced to a function of one variable, making probability tables easy to construct. The specific tables used in SIFTER are described in Appendix B.

SUMMARY

The purpose of this appendix has been to describe the mathematical basis for the SIFTER fingerprint technical search system. First, some terms and notations were defined. The calculation of matching probability was explained in general terms not specific to fingerprints. Then the use of matching probability as a candidate selection score was shown to be optimal. Finally, the assumptions and approximations required to adapt the system to NCIC fingerprint codes were explained.

APPENDIX B

SIFTER PROGRAM SPECIFICATIONS AND COMPLETE TEST RESULTS

GENERAL

In developing SIFTER, three main computer programs and several small utility programs were written in Fortran IV language. They were tested and run on an IBM 370 Model 155 using HASP operating system. The main programs are described in detail in this appendix. Several computer output listings are presented, including the test data, and test results. For the sake of continuity in the text, all exhibits are located at the end of the appendix.

Fingerprint Data

The data sets used have already been described and will be referred to as data set #1 and #2. (See Exhibits B-1 and B-2 for complete listings.) Originally, the fingerprint classifications were in the alphanumeric NCIC code. To simplify programming, the codes were converted to all numbers as shown in Exhibit B-3.

Each data set consisted of pairs of fingerprint codes A and B where A was defined as an inquiry print and B the library file print. In this appendix, A and B will refer to the entire fingerprint code (all 10 fingers), and A(I) and B(I) will refer to codes on one finger, i.e., finger I. Most of the processing is done for one finger at a time.

In addition to the pairs of matching fingerprint codes, a library file of 10,000 codes was available for use in test runs.

Programs

The three main SIFTER programs are SIFTER-NUMER, SIFTER-DENOM, and SIFTER-SEARCH. The first two were designed to construct probability tables for use in the search program. All three programs are important and are described in the following sections.

Timing

One hundred randomly chosen inquiry classifications were searched in a batch against a library file of 10,000 codes. The computer time used was 1 minute, 35 seconds for data set #1, and 1 minute, 45 seconds for data set #2. Most of this time was not used to search the file, but rather to set up the tables and read the library file (which was only done once, no matter how many arguments were searched). Search for only one argument against the file took 45 seconds. Thus, increasing the number of arguments searched against the library file did not add appreciably to the running time of the program.

Search time per argument is estimated at .5 second. This was estimated by noting that running time for one argument was 45 seconds while running time for 100 arguments was 95 seconds. The difference is 50 seconds for 99 cases. These 50 seconds also include the time taken for printing the output, implying that actual search time per argument is even less than .5 second. Search time is proportional to file size, therefore a single search of a one-million card file with the present system would require 50 seconds.

In an operational system, many optimizing procedures would be used, including tighter computer code and microprogramming techniques. These changes should cut the search time

considerably. In converting to an on-line instead of a batch system, random access files allowing rapid record retrieval would be used. It is difficult to estimate how the search time would be affected, however.

SIFTER-NUMER

Description

SIFTER-NUMER sets up the raw numerator tables used in SIFTER-SEARCH to calculate the SCORE value. The program logic is shown in the flowchart for SIFTER-NUMER (Exhibit B-4). As shown in the flowchart, an A and B pair is used as data where A is the inquiry print and B the file print. The given alphanumeric codes are changed to numeric codes (see Exhibit B-3), and the resulting codes tallied, one finger at a time, depending on the value of A(I) and B(I) for the finger being considered. The program prints out the raw tables, labeled N1 - N5, and also punches the same tables on cards to be used as input for SIFTER-SEARCH.

Raw Tables

Five mutually exclusive tables, namely N1, N2, N3, N4, and N5 were created. They are tallies of the number of times an A(I) and B(I) combination actually occurs in the data set. These tables are labeled with N, indicating they are numerator tables. Tables N1 and N2 were used when both A(I) and B(I) are loops, and tables N3, N4, and N5 were used when at least one finger is not a loop. An additional table, N6, was simply a tally of each code found in the data set.

Each numerator table is described below, with the use of Exhibit B-5, an example listing of numerator tables.

Table N1

Entries in Table N1 were for A(I)s and B(I)s that were both loops (ridge counts under 100), with ridge counts that differed by five or less. This table was used for 68% of data in data set #1.

In the table, the left-hand column (see Exhibit B-5, Table N1) indicates the ridge count for print A(I). The next eleven columns are tallies of the data according to the value of A(I) minus B(I). The right-hand column is the total of the tallies in the row. The last row is the total of the columns.

For example, given the pair of codes A(I)=4 and B(I)=4 for the same finger, tally was made in the fourth row of the table under the column headed 0 (because A(I)-B(I) = 0). Twenty-nine such tallies are shown in Exhibit B-5. Given A(I)=4 and B(I)=7, a tally would again be made in row 4, but this time under heading -3 because A(I)-B(I) = -3. Seven such tallies are shown in the exhibit.

Table N2

Entries in Table N2 were for A(I)s and B(I)s that were both loops with codes that differed by more than five ridge counts. This table was used in .21% of the data in data set #1, indicating that this difference occurred quite rarely.

Examining Exhibit B-5, Table N2, the left-hand column indicates the absolute value of A(I) minus B(I) which may be a single number or a group of values. The right-hand column indicates the total tallies made in the row. The last row is again a column total.

For example, if A(I) = 25, B(I) = 18, a tally was made in the right column corresponding to $|A(I)-B(I)| = 7$. One such tally is shown in the exhibit. If A(I) = 25 and B(I) = 8, then a tally would be made in the category 14-46. The number of such tallies in the exhibit is zero.

Table N3

Entries in Table N3 were made when either A(I) or B(I) was a loop and the other was an arch. This table was used to .7% of the data in data set #1. The left-hand column as shown in the exhibit indicates the ridge count for the loop data (either A(I) or B(I)). The column headed 101 was for plain arches and the one headed 102 was for tented arches. Column four is a row total, and the last row is a column total.

As an example tally, if A(I) = 5, B(I) = TT a tally would be made in row five, under column 102. One such tally is shown in Exhibit B-5. A tally for total would also be made. If A(I) = TT and B(I) = 5, the same tally would be made. As it turned out, all entries were for tented arches, rather than for plain arches. Apparently, plain arches and loops are never confused. A tented arch vs. loop error is quite common, however.

Table N4

Entries in Table N4 were made when A(I)s and B(I)s were both non-loops (whorls and arches). This table was used for 23.5% of data set #1.

The left-hand column indicates the numeric codes and their alphanumeric equivalents as do the column headings.

Tallies were made according to the value of A(I) (rows) and B(I) (columns). The right-hand column and the last row are row and column totals respectively.

For example, if A(I) = AA, B(I) = TT a tally would be made in the first row (labeled 101-AA) under the column headed (TT-102). Six such tallies are shown in Exhibit B-5.

In this table, off-diagonal elements indicated differences in codings on the same person's prints. Output indicated that plain and tented arches were easily confused. Also, whorl types were sometimes different while the tracings were not (or vice-versa). For example, a PM might be confused with a PO or PI (same whorl type) or a PI confused with a CI or PI (same tracing type).

Table N5

Entries in Table N5 were made when either A(I) or B(I) was a whorl, scar, or amputation, and the other was a loop. This table was used for .1% of the data in data set #1 and 1.3% in data set #2. This difference in percentages is accounted for by "SR" classifications which occurred more often in data set #2 because codings in that set were made at different times.

Tallies were made as in Exhibit B-5, Table N-5. In the left-hand column, groups of ridge counts are indicated for loop data A(I) or B(I). The next 14 columns are tallies of the data according to the value given at the top of the column. The right-hand column and the last row are row and column totals.

For example, if A(I) = 10, B(I) = SR, a tally in the row labeled 1-10, and column 104 would be made. Nine such tallies are shown in the exhibit. The same tally would be made for A(I) = SR, B(I) = 10. In either case, a column tally and a row tally were also made.

It is interesting to note that the percentage of usage for each of the tables is very close for the two data sets, indicating that the same types of differences were made in coding both sets of data. However, larger differences were found in coding in data set #2, particularly in ridge counts.

Table N6

Entries in Table N6 were made every time an entry in another table was tallied. The table indicates how many of each classification number are found on A prints (column headed A), B prints (column headed B), and in the total data (column headed Total).

Looking at Exhibit B-6, the first column is a listing of numbers 1-116 where 1-100 indicate the codes chosen to represent loop data and 101-116 indicate codes chosen to represent alphabetic codes for arches, scars, amputations, and whorls. The second column, headed A, indicates the number of tallies that were made for the corresponding inquiry codes in the left-hand column. The column headed B is for file codes. Thus, a distribution of counts for all the data is made.

Using the example used for Table N1, namely A(I) = 4, B(I) = 7, a tally would be recorded in row 4 under column A and in row 7 under column B. There are 67 and 80 such tallies in Exhibit B-5, respectively. At the same time, total tallies are made in

the total column for A and B. There are 2,480 such tallies in Exhibit B-5, corresponding to the 284 fingerprint cards of data set #2.

Normalized Tables

The normalization of the raw tables is really done in SIFTER-SEARCH. However, it will be described here, since this is its logical place in the system.

The raw tables created by SIFTER-NUMER are normalized in order to convert the tallies to probabilities of choosing a B(I) value given an A(I) value. Normalization was done by dividing the number of tallies made in the table by the number of possible tallies in a given category.

The actual normalization factors used are shown in Exhibit B-6 where N6(X) indicates values in Table N6 just described. Only tallies in column A are used in the calculations.

The normalization constants indicated in Exhibit B-6 (other than 2) show how many ridge counts were tallied together as a group. The factor 2 comes from splitting tables N3 and N5 into two sub-tables each (N3AB, N3BA, N5AB, and N5BA -- see Exhibit B-7). The splitting was required in order to distinguish between the inquiry and file codes and determine the correct conditional probability. The tallies in the split tables were divided by 2 to avoid counting each tally twice.

To normalize the tables, each table entry is divided by the normalization factor and the result reinserted in the table. For example, to normalize the entry used as the example for Table N1, A = 4, B = 4, the final entry tallied in Table N1

(29 in Exhibit B-5) would be divided by its corresponding normalization factor, namely the entry in row 4, column A of Table N6 (67 in the exhibit). The normalized value would be $29/67 = .433$.

Smoothed Tables

After normalization, NUMER tables were smoothed. This was done to reduce the chance of a "0" being found in the tables when, in fact, the classification pair being looked up was relatively common, but just did not happen to be in the data set that established the tables. For example, the pair A(I) = 17 and B(I) = 18 may not have occurred in the data set used to build the tables. However, it is a likely combination.

Only NUMERATOR tables were smoothed (N1 - N5). A variation of "exponential smoothing" was used on the data, column by column. Steps were generally:

- (1) An initial starting value was chosen (SMOOTH(I,J)) (either the first value found in the normalized table, or if this value was very small, a certain larger value was inserted as a starting value.
- (2) A damping factor D (or weight factor) was chosen. A value of .2 was used because it seemed to give good results.)
- (3) The new table value (SMOOTH (I+1,J)) was calculated by multiplying the damping factor times the original table value (D*TABLE (I+1,J)) and then adding 1-D times the last smoothed value in the table (SMOOTH (I,J)).

Thus, the equation used was:

$$\text{SMOOTH (I+1,J)} = D * (\text{TABLE (I+1,J)}) + (1-D) * (\text{SMOOTH (I,J)})$$

where D = damping factor (.2 for all tables except N3;
.8 for Table N3)

SMOOTH (I+1,J) = new value for table; (I+1) is row
position, J is column position).
Initially this is SMOOTH (1,J) =
starting value.

The damping factor (between 0 and 1) is chosen in this method according to how the data should be weighted. A small factor (less than .5) puts more weight on the last table value smoothed, than on the next table value. A larger factor (over .5) has just the opposite effect.

Tables N1 and N3 were smoothed in two sections; i.e., radial loops and ulnar loops were treated separately. Thus, in Table N1, rows 1-50 were smoothed. Then, row 51 was used as another starting value and the process repeated.

After smoothing, if a zero still remained in a table, it was replaced by a small value, in this case, 1/(library file size) or .0001 was used. This was to prevent any error in coding from being catastrophic and causing a zero probability to be calculated.

After the entire smoothing operation, the tables were renormalized so that the probabilities would add to one. An example of smoothed and renormalized tables is shown in Exhibit B-7. The damping factor used in these calculations is .2 for all tables except N3 where .8 was used.

SIFTER-DENOMINATOR

The tables of DENOMINATOR values to be used in the calculation of SCORE were constructed by considering only prints in the library file (B).

Preliminary Process

Before constructing the tables, the library file was converted to all numeric codes (shown in Exhibit B-3) and sorted into ascending order. Eighteen categories (rather than the 116 in Exhibit B-3) were used for grouping. All ulnar loops were treated as one category, as were all radial loops. The sixteen non-loop categories were left unchanged. The codes were then sorted numerically and the number of identical code types, using the simplified classification system, were counted. These "counts" were stored as an additional entry in the library file (see Exhibit B-8, page 1 for the flowchart).

Table Construction

The flowchart in Exhibit B-8 shows how the DENOM tables were constructed. Each print in the file was treated finger by finger. The statistical dependence of the fingers was taken into account in the design of the tables.

Four mutually exclusive tables, D1 - D4 were constructed, where the D denotes DENOMINATOR. D3 and D4 were each divided into four sections, namely D3 Section 1, 2, 3, and 4, and D4 Section 5, 6, 7, and 8. Tallies were made only for loop data.

SIFTER-DENOM prints out the raw tables, D1 through D4 and also punches the same tables on cards to be used as input to SIFTER-SEARCH.

Raw Tables D1 and D2

Tables D1 and D2 were used for tallying the first time a loop was encountered in a print. D1 was used for ulnar loops and D2 for radial loops. In the library file used, 61.5% of the entries were ulnar loops and 4% were radial loops. The other 34.5% were non-loops.

Exhibit B-9 shows an example of the tallies made. The left-hand column lists the ridge count of loops in the library file print. The next ten columns are tallies of the number of times a given ridge count was found in the library file for the finger indicated at the top of the column. The right-hand column and the last row of each table are row and column totals.

For example, if the ridge count on finger 4 was 10, a tally would be made in row 10 (indicating the ridge count) in the column headed 4 (indicating the finger number). There are 234 such tallies indicated in Exhibit B-9.

Raw Tables D3 and D4

When more than one loop of the same type (ulnar or radial) was encountered in the same set of fingerprints, tallies were made in Tables D3 and D4. Table D3 was used for tallying if the finger was an ulnar loop and D4 was used if the finger was a radial loop.

The basic idea was to find the distribution of ridge counts on each finger and not destroy the statistical dependence among fingers.

By analyzing fingerprint codes, it can be observed that if one finger has a high ridge count, the rest probably also have high ridge counts. In addition, a thumb usually has a higher ridge count than an index finger, while the other three fingers typically have nearly equal ridge counts, somewhere between the counts on thumbs and index fingers.

To preserve dependence, Tables D3 and D4 were constructed using complete sets of codes (10 fingers per set) in the order 1 through 10. The distribution of finger I (I = 2,3,...10) was tabulated about the average ridge count of fingers 1 through (I-1), radial and ulnar loops being considered separately. Ideally, a large number of tables, perhaps 50, i.e., one for each possible average ridge count, should be constructed. Instead, the number of tables was reduced to four each for radial and ulnar loops. Each sub-table corresponds to a small range in the average ridge count as indicated in Exhibit B-9.

Notice in the exhibit the concentration of counts near the average of the previous counts (row "0"). This confirms the notion of dependence among fingers. Also notice in Table D3, section 2, the tendency of the index fingers (#2 and #7) to have counts below the average, and the tendency of the other fingers, particularly the left thumb (#6), to have counts higher than the average.

In the library file used, the following percentages of the data fell into the eight tables:

| <u>Table</u> | <u>Percentage</u> |
|---------------|------------------------------------|
| D3, Section 1 | 15.7% |
| D3, Section 2 | 23.7% |
| D3, Section 3 | 10.6% |
| D3, Section 4 | 1.6% |
| | <u>51.6%</u> Total for counts 1-49 |

| <u>Table</u> | <u>Percentage</u> |
|---------------|------------------------------------|
| D4, Section 5 | .33% |
| D4, Section 6 | .20% |
| D4, Section 7 | .21% |
| D4, Section 8 | .18% |
| | <u>.92%</u> Total for counts 51-99 |

The other 47.4% were non-loop codes and sets that had only one ulnar or radial loop in the set of 10 prints.

Example of Tally

An example of the tally procedure for a print record is as follows:

| | | | | |
|-----------|----|----|----|-----------|
| finger #1 | 2 | 3 | 4 |etc. |
| count 10 | 15 | 53 | 07 |etc. |

(1) The count of 10 is saved and a tally made in Table D1, row 10, column 1. This indicates finger 1 has a count of 10.

(2) A tally is made in Table D3 in the column headed 2 (indicating finger 2). The row of Table D3 to be used is determined by finding Average minus Present. Average, the average of fingers that are ulnar loops that have already been considered, is 10. Present, the ridge count of the finger presently being considered, is 15. The section of Table D3 to be used is Section 1 because $\text{Average} = 10$. The row of the Table D3, Section 1 used is $\text{Average-Present} = 10 - 15 = -5$.

(3) The count of 53 is saved and a tally made in Table D2, row 3, column 3. This indicates finger 3 has a count of 53.

(4) As in step (2) a tally is made in Table D3, in the column headed 4 (indicating finger 4). The section of D3 used is Section 2 because $\text{Average} = \frac{10 + 15}{2} = 13$. The tally is recorded in row $(\text{Average-Present}) = 13 - 07 = +6$.

Normalized Tables

DENOMINATOR tables were normalized to convert the tallies to the probability of choosing a given B(I) value. This is similar to that done in the NUMERATOR tables. Normalization was done separately for each table (considering D3 and D4 each as four separate tables). Again, this normalization process was done in SIFTER-SEARCH, but this is its logical place in the system.

All DENOM tables are normalized in the same way. A table entry for a given finger is normalized by dividing the entry by the column total for that found in the last row of the table. For example, using Exhibit B-9, Table N1, the normalized table entry for the row 10, column 4 would be $234/5171 = .0453$, since 234 is the raw table entry and 5171 is the column total.

After normalization, entries are replaced in the tables, and normalized DENOMINATOR tables are the result. These tables are not smoothed like the NUMERATOR tables. Smoothing is not required since a zero entry will never be looked up. An example of normalized DENOMINATOR tables is shown in Exhibit B-10.

SIFTER-SEARCH

Description

SIFTER-SEARCH searches the library file and calculates SCORE using smoothed and normalized NUMERATOR and DENOMINATOR tables in a table look-up manner. The normalization and smoothing was done in this program, but in the operational system it would be done beforehand.

The program operates in two modes. MODE 1 calculates SCORE for an inquiry card A and file card B contained in the 10,000 card library. A given inquiry card is compared to the entire library file and a tally of the number of scores that exceed given threshold values is made, indicating the number of possible matches for each inquiry code. SIFTER-SEARCH can be run for any number of inquiry cards and any size library file.

MODE 2 calculates SCORE for selected pairs of inquiry and file cards. It was used to calculate scores for known matching pairs of codes, whereas MODE 1 was used to calculate scores for non-matching codes. The two modes were made separate only for convenience. The same results would have been obtained if the known matching codes had been added to the 10,000 card library and only one search were made. Both modes used the same numerator and denominator tables and calculated scores identically.

In MODE 1, in order to minimize the computer time used in reading the library file, the program is written to read the library file only once, no matter how many inquiry cards were searched. This was done by first reading and storing all the inquiry cards, and then reading the library file one print at a time. The library file print B is then compared against all the inquiry prints A, before another print is read. The actual method used to do this is shown in the flowchart in Exhibit B-11, SIFTER-SEARCH.

To further save computer time, an initial screening based on Henry Primary was included in MODE 1. In practice, the file would be segmented by Henry Primary; referencing of the Primary would be necessary.

Numerator Calculation

SIFTER-SEARCH performs table look-ups into Tables N1-N5 using the inquiry print for A(I) and the library file print for B(I). This look-up is done one finger at a time and the probabilities for the ten finger pairs are multiplied together. The final result after ten multiplications is called NUMER.

Denominator Calculation

SIFTER-SEARCH performs table look-ups into Tables D1-D4 using only file print B(I). This look-up is done one finger at a time and the results for each of the ten fingers are multiplied together. The final result is then multiplied by the count stored in the library file and divided by the total number of prints in the file (10,000). DENOM is the result after the multiplications and division are performed.

Input--MODE 1 and MODE 2

The following is a listing of the input and the order it is used in SIFTER-SEARCH. The use of the input may be followed in the flow chart in Exhibit B-11.

1. Damping factors for smoothing
2. NUMERATOR tables for the data set used, created without the 100 pairs of prints being used as test prints.
3. DENOM tables for the library file
4. Mode number (1 or 2)
5. Library file data, number of prints in file, number of search arguments (MODE 1 only)
6. Threshold values (MODE 1 only)
7. Data - 100 pairs of prints chosen randomly from data set being run.

The NUMERATOR tables used are tallied using the data sets without the test data so that the system parameters (the tables) are independent of the test. This guarantees unbiased results.

Output - MODE 1

The complete SIFTER-SEARCH output for both data sets is shown in Exhibits B-12 and B-13. The output consists of a listing of the search arguments used and the corresponding number of tallies made for scores that were greater than the threshold values given at the top of the page.

The left-hand column is a listing of the number of the argument being searched (1-100). This number is used only for identification purposes. The next ten columns indicate the alphanumeric coding of the inquiry card being searched against the library file. (Note that the codings on the library file are not listed in the output, but are available upon request.) The final ten columns are tallies of how many scores were calculated to be greater than the threshold value given at the top of the column. The last row is a column total indicating the total number of scores calculated for all inquiry prints that were greater than the threshold values. For example, in Exhibit B-12, the first and second codes had no potential matches. The third code had seven matches with scores above $.3 \times 10^{-1}$, three greater than 3×10^1 and only one above $.1 \times 10^4$.

Output - MODE 2

MODE 2 output for both data sets is shown in Exhibit B-14 and B-15. The output lists data number, inquiry print A, file print B, NUMER, DENOM, and SCORE. Two lines of output are generated for each SCORE calculation. Note the variation in scores from a high of about 10^{12} to a low of 10^{-7} . The scores

are fairly consistently high, however. In the exhibit, the left-hand column is a listing of the data pair being used (1-100). They are numbered the same as in MODE 1. The next 10 columns indicate the alphanumeric coding of the inquiry print A, and the file print B. The value of NUMER (see NUMER calculations) is printed on the first output line. The value of DENOM (see DENOM calculations) is printed on the second line along with SCORE, which is equal to NUMER/DENOM.

CONCLUSION

SIFTER is an efficient, computerized method of searching a library file for a given inquiry fingerprint. The method can be used to produce any number of "potential matches," depending on the setting of the threshold of value. The probability that a match for a given inquiry print will be found, if it exists, in the library file is high and the cost of running the program is comparatively low (especially if multiple inquiry prints are searched at one time).

FINGERPRINT DATA LISTING
DATA SET NUMBER 1

| 1 | N C I C C U J I S | | | | | | | | | | R E F E R E N C E S | | | | | | | | | | | |
|-----|-------------------|----|----|----|----|----|----|----|----|----|---------------------|----|----|----|----|----|----|----|----|----|---|--|
| | 2 | 3 | 4 | 5 | 6 | 7 | 8 | 9 | 10 | F | R | F | R | F | R | F | R | F | R | F | R | |
| 1. | 20 | PI | 17 | 00 | 17 | 11 | PO | PM | 14 | 14 | 04 | 20 | 08 | PI | | | | | | | | |
| | 20 | PI | 17 | 00 | 18 | 19 | PI | PM | 14 | 14 | 04 | 20 | 08 | PI | | | | | | | | |
| 2. | PI | AA | 11 | 02 | 06 | PO | AA | 11 | 11 | 06 | 03 | 01 | 07 | 11 | | | | | | | | |
| | PI | AA | 11 | 02 | 07 | PO | AA | 11 | 11 | 05 | 03 | 01 | 07 | 11 | | | | | | | | |
| 3. | 10 | AA | 11 | 11 | 08 | 03 | AA | 01 | 11 | 05 | 04 | 04 | | | | | | | | | | |
| | 10 | AA | 11 | 05 | 07 | 03 | AA | 01 | 11 | 05 | 04 | 11 | | | | | | | | | | |
| 4. | PM | PI | 00 | PM | PM | 23 | 15 | 01 | XX | PI | 01 | 00 | 02 | PM | | | | | | | | |
| | PM | PI | 00 | PM | PM | 24 | 15 | 01 | XX | PI | 01 | 00 | 02 | PM | | | | | | | | |
| 5. | 18 | 01 | 11 | 03 | 07 | 17 | 11 | 11 | 10 | 14 | 02 | 11 | 03 | AA | | | | | | | | |
| | 18 | 01 | 11 | 03 | 07 | 17 | 11 | 11 | 10 | 14 | 02 | 11 | 03 | AA | | | | | | | | |
| 6. | 19 | 06 | 16 | 19 | 16 | 01 | 54 | 10 | 15 | 15 | 06 | PI | | | | | | | | | | |
| | 20 | 06 | 17 | 18 | 17 | 01 | 54 | 09 | 10 | 14 | 06 | PI | | | | | | | | | | |
| 7. | PM | X1 | PM | PO | 15 | 01 | PI | 14 | 16 | 12 | 03 | CM | | | | | | | | | | |
| | PM | X1 | CM | PO | 15 | 01 | PI | 14 | 17 | 12 | 03 | PM | | | | | | | | | | |
| 8. | 19 | 13 | 09 | 00 | 16 | 15 | 10 | 17 | PI | 01 | 10 | PI | | | | | | | | | | |
| | 15 | 14 | 09 | 00 | 18 | 15 | 09 | 15 | PI | PI | 10 | CI | | | | | | | | | | |
| 9. | 23 | PI | 15 | PM | 18 | 16 | PM | 19 | PI | 01 | 02 | 01 | 07 | PM | | | | | | | | |
| | 20 | PI | 13 | PM | 20 | 18 | PM | 19 | PI | 01 | 02 | 01 | 07 | PM | | | | | | | | |
| 10. | PI | 07 | 07 | PM | 17 | 01 | 00 | 11 | 22 | 17 | 04 | PU | | | | | | | | | | |
| | PO | 07 | 05 | PM | 17 | 01 | 07 | 12 | 22 | 18 | | | | | | | | | | | | |
| 11. | 26 | 15 | 09 | 08 | 04 | 11 | 08 | 08 | 13 | 03 | | | | | | | | | | | | |
| | 27 | 15 | 09 | 09 | 11 | 11 | 11 | 07 | 14 | 00 | | | | | | | | | | | | |
| 12. | PO | 14 | 15 | 00 | 14 | PO | 14 | CI | 16 | 03 | 00 | 06 | PO | | | | | | | | | |
| | PO | 14 | 15 | 00 | 15 | PI | PO | 14 | CI | 14 | 03 | 00 | | | | | | | | | | |
| 13. | 23 | PI | 12 | 00 | 12 | 12 | 01 | 09 | PM | 13 | 04 | PO | | | | | | | | | | |
| | 23 | PI | 12 | PM | 10 | 14 | 03 | 09 | PM | 13 | 02 | PM | | | | | | | | | | |
| 14. | 20 | 15 | 15 | 12 | 11 | 20 | 00 | 13 | 14 | 10 | 07 | PO | | | | | | | | | | |
| | 20 | 13 | 15 | 12 | 13 | 21 | PO | 13 | 13 | 12 | 07 | 00 | | | | | | | | | | |
| 15. | 05 | 11 | 11 | 15 | 02 | AA | 52 | 11 | 16 | 12 | 02 | 51 | 03 | 02 | 05 | 11 | 07 | 11 | 08 | 03 | | |
| | 05 | 11 | 11 | 15 | 03 | AA | 55 | 04 | 14 | 13 | 03 | 01 | | | | | | | | | | |
| 16. | 24 | 01 | 10 | 17 | 17 | 15 | 00 | PM | 17 | 17 | | | | | | | | | | | | |
| | 24 | 01 | 09 | 17 | 17 | 10 | 00 | PM | 16 | 16 | 08 | PU | | | | | | | | | | |

B-20

| 1 | N C T C C U D E S | | | | | | | | | | R E F E R E N C E S | | | | | | | | | | | |
|-----|-------------------|----|----|----|----|----|----|----|----|----|---------------------|----|----|----|---|---|---|---|---|---|---|--|
| | 2 | 3 | 4 | 5 | 6 | 7 | 8 | 9 | 10 | F | R | F | R | F | R | F | R | F | R | F | R | |
| 19. | PO | PI | 06 | 05 | 00 | PI | 08 | 02 | 03 | 05 | 02 | PM | 09 | 11 | | | | | | | | |
| | PO | PM | 07 | 07 | 00 | PI | 08 | 05 | 03 | 05 | 09 | 11 | | | | | | | | | | |
| 20. | 16 | 11 | 07 | PI | 07 | 14 | 07 | 07 | 09 | 04 | 05 | 11 | | | | | | | | | | |
| | 15 | 10 | 07 | PI | 07 | 15 | 07 | 07 | 09 | 04 | 04 | PM | | | | | | | | | | |
| 21. | 18 | 10 | 12 | 14 | 13 | 15 | 00 | 10 | 14 | 09 | | | | | | | | | | | | |
| | 18 | 10 | 13 | 12 | 12 | 15 | 59 | 10 | 14 | 10 | | | | | | | | | | | | |
| 22. | PO | PI | PO | PI | 15 | 19 | 01 | 17 | PI | 15 | | | | | | | | | | | | |
| | PO | PI | PO | PI | 14 | 19 | 01 | 16 | PI | 14 | | | | | | | | | | | | |
| 23. | 00 | 15 | 13 | 00 | 16 | 01 | 13 | 17 | PI | 16 | | | | | | | | | | | | |
| | PO | 15 | 13 | 00 | 16 | 01 | 13 | 16 | PI | 16 | | | | | | | | | | | | |
| 24. | 02 | 04 | 04 | 05 | 05 | AA | 11 | 07 | 07 | 11 | 08 | SR | 10 | 03 | | | | | | | | |
| | 02 | 04 | 04 | 05 | 04 | AA | 11 | 07 | 07 | 11 | 07 | 01 | 08 | SR | | | | | | | | |
| 25. | 17 | 17 | 14 | 17 | 12 | 01 | 12 | 00 | 15 | 11 | | | | | | | | | | | | |
| | 18 | 17 | 14 | 18 | 13 | 01 | 13 | 00 | 15 | 10 | | | | | | | | | | | | |
| 26. | 06 | 07 | 10 | 02 | 04 | 11 | 06 | 07 | 07 | 05 | 07 | 11 | | | | | | | | | | |
| | 07 | 03 | 11 | 05 | 05 | 07 | 05 | 09 | 09 | 05 | 06 | 13 | | | | | | | | | | |
| 27. | 10 | 04 | 11 | 05 | 01 | 07 | 04 | 02 | 04 | AA | | | | | | | | | | | | |
| | 10 | 04 | 11 | 05 | 01 | 06 | 05 | 02 | 04 | AA | | | | | | | | | | | | |
| 28. | 11 | 04 | 06 | 13 | 09 | 11 | 04 | 00 | 06 | 10 | | | | | | | | | | | | |
| | 11 | 04 | 05 | 13 | 09 | 11 | 04 | 00 | 07 | 11 | | | | | | | | | | | | |
| 29. | 10 | 00 | 13 | 14 | 14 | 13 | 10 | 13 | PI | 15 | 08 | 10 | | | | | | | | | | |
| | 17 | 06 | 12 | 15 | 14 | 14 | 09 | 13 | CI | 12 | | | | | | | | | | | | |
| 30. | PL | 11 | 05 | 11 | 03 | PI | 10 | 07 | CI | 05 | | | | | | | | | | | | |
| | PO | 12 | 05 | 11 | 11 | PI | 10 | 06 | CI | 06 | | | | | | | | | | | | |
| 31. | 20 | 12 | 17 | 17 | 16 | 16 | PO | 11 | 17 | 17 | | | | | | | | | | | | |
| | 21 | 13 | 12 | 18 | 17 | 16 | PO | 11 | 21 | 18 | | | | | | | | | | | | |
| 32. | 19 | PI | PM | PM | 10 | 15 | PI | PM | PI | 08 | 07 | PM | | | | | | | | | | |
| | 20 | PI | PM | PM | 10 | 16 | PM | PM | PM | 09 | 07 | PI | 09 | PI | | | | | | | | |
| 33. | 21 | 17 | 14 | 14 | 10 | 20 | PO | 13 | 12 | 10 | | | | | | | | | | | | |
| | 21 | 15 | 14 | 14 | 08 | 22 | PO | 13 | 11 | 10 | 07 | 00 | | | | | | | | | | |
| 34. | PO | PI | 14 | PO | 17 | PI | PO | 13 | 14 | 14 | 04 | 00 | | | | | | | | | | |
| | PO | PI | 14 | PO | 15 | PI | PO | 13 | 14 | 14 | 04 | PO | | | | | | | | | | |
| 35. | 15 | PI | 10 | PM | 00 | 14 | 00 | 14 | 16 | CI | 04 | PO | | | | | | | | | | |
| | 14 | PI | 10 | PM | 00 | 17 | 00 | 15 | 16 | CI | 05 | PO | | | | | | | | | | |
| 36. | PO | 10 | 07 | 00 | 14 | PI | 24 | 04 | 09 | CI | | | | | | | | | | | | |
| | PO | 11 | 08 | 00 | 13 | PI | 26 | 04 | 11 | CI | | | | | | | | | | | | |

B-21

Exhibit B-1 (Continued)

FINGERPRINT DATA LISTING
DATA SET NUMBER 1

| | N C I C C O D E S | | | | | | | | | | R E F E R E N C E S | | | | | | | | | |
|-----|-------------------|----|----|----|----|----|----|----|----|----|---------------------|---|----|----|----|----|----|----|---|---|
| | 1 | 2 | 3 | 4 | 5 | 6 | 7 | 8 | 9 | 10 | F | R | F | R | F | R | F | R | F | R |
| 37. | 17 | 19 | 10 | PM | PU | 12 | 11 | 11 | 18 | CI | | | | | | | | | | |
| | 15 | 16 | 09 | PM | PU | 11 | 11 | 09 | 18 | CI | | | 04 | PU | 10 | DI | | | | |
| 38. | PM | 62 | 11 | 13 | 10 | 13 | 07 | 11 | 12 | 07 | | | | | | | | | | |
| | PM | 21 | 10 | 11 | 07 | 13 | 07 | 10 | 10 | 00 | | | | | | | | | | |
| 39. | 14 | TT | C1 | C4 | 06 | 15 | 53 | TT | 05 | C5 | | | 03 | TT | 07 | TT | | | | |
| | 15 | TT | C1 | C4 | 06 | 15 | TT | TT | C4 | C4 | | | 03 | TT | 07 | 52 | | | | |
| 40. | CO | PM | PU | CI | CO | 20 | 18 | PI | CI | 14 | | | 02 | PI | | | | | | |
| | CC | PM | PU | CI | CO | 20 | 18 | PI | CI | 14 | | | | | | | | | | |
| 41. | 20 | TT | 13 | 04 | 07 | 17 | 58 | 15 | 14 | 09 | | | | | | | | | | |
| | 20 | TT | 13 | 04 | 06 | 17 | 58 | 13 | 13 | 09 | | | | | | | | | | |
| 42. | 19 | 52 | C5 | C2 | 12 | 11 | 50 | C5 | 17 | 14 | | | | | | | | | | |
| | 18 | 53 | C6 | F0 | 12 | C9 | 58 | C5 | 16 | 13 | | | | | | | | | | |
| 43. | PU | PI | PU | PU | 19 | PI | PI | 15 | CI | 15 | | | | | | | | | | |
| | PO | PI | PU | PU | 16 | PI | PI | 15 | CI | 14 | | | | | | | | | | |
| 44. | 15 | 13 | 09 | 14 | 10 | PI | 10 | 14 | 12 | 09 | | | | | | | | | | |
| | 14 | 14 | 10 | 15 | 10 | PI | 09 | 14 | 12 | 09 | | | | | | | | | | |
| 45. | PM | PI | 12 | 10 | 10 | PI | PI | 15 | PI | 14 | | | | | | | | | | |
| | PM | PI | 13 | 18 | 18 | PI | PI | 14 | PI | 14 | | | 04 | CO | | | | | | |
| 46. | PO | C3 | 14 | 10 | 21 | 06 | TT | 17 | 21 | 20 | | | 01 | PM | | | | | | |
| | PO | 61 | 14 | 22 | 21 | 06 | TT | 16 | 20 | 19 | | | 01 | PM | 07 | TT | 51 | | | |
| 47. | 10 | 62 | 15 | 17 | 13 | 04 | PU | CI | 17 | 13 | | | 08 | PI | | | | | | |
| | 11 | 62 | 13 | 16 | 13 | C5 | PU | PI | 16 | 12 | | | | | | | | | | |
| 48. | 18 | PU | 10 | CO | PU | PU | 08 | X1 | PI | | | | | | | | | | | |
| | 17 | PU | 08 | CO | PU | PU | 09 | X1 | PI | | | | 09 | XM | | | | | | |
| 49. | PO | PI | 10 | PU | 16 | DI | PU | PI | PI | 15 | | | 01 | IO | | | | | | |
| | 00 | PI | PU | PU | 15 | DI | PU | PI | PI | 17 | | | 01 | PU | | | | | | |
| 50. | 18 | C5 | C4 | C2 | 07 | 11 | C3 | 04 | TT | 02 | | | 04 | TT | 09 | 01 | | | | |
| | 15 | C5 | C4 | C2 | C2 | 11 | C3 | C3 | TT | CI | | | 04 | TT | 09 | CI | | | | |
| 51. | CO | DM | 10 | PU | PU | CO | 14 | PI | PM | | | | 04 | PM | 06 | PM | 07 | PU | | |
| | CO | DM | 10 | PM | PU | PM | CO | 14 | PI | PM | | | 02 | PM | 04 | PU | 06 | PU | | |
| 52. | PU | PM | 15 | PM | CO | PI | PI | 16 | PI | 10 | | | 04 | PU | 10 | CI | | | | |
| | PU | PM | 13 | PM | CO | PI | PI | 16 | PI | 10 | | | 04 | PU | 05 | PU | 10 | CI | | |
| 53. | PO | DI | PI | PM | PU | DI | PU | PO | PI | 23 | | | 03 | CI | 04 | PI | | | | |
| | PO | DI | PI | PM | PU | DI | PU | PO | PI | 23 | | | 02 | PU | | | | | | |

B-22

Exhibit B-1 (Continued)

FINGERPRINT DATA LISTING
DATA SET NUMBER 1

| | N C I C C O D E S | | | | | | | | | | R E F E R E N C E S | | | | | | | | | |
|-----|-------------------|----|----|----|----|----|----|----|----|----|---------------------|---|----|----|----|----|----|----|----|----|
| | 1 | 2 | 3 | 4 | 5 | 6 | 7 | 8 | 9 | 10 | F | R | F | R | F | R | F | R | F | R |
| 55. | CO | CI | TT | CO | C5 | 21 | 13 | 03 | CI | 08 | | | 09 | 12 | | | | | | |
| | CO | CI | TT | CO | C4 | 21 | 13 | C4 | CI | 09 | | | 09 | 13 | | | | | | |
| 56. | 10 | 13 | 10 | 12 | 12 | 07 | 11 | 04 | 06 | 09 | | | | | | | | | | |
| | 10 | 13 | 09 | 12 | C9 | 06 | 10 | 06 | C7 | 09 | | | | | | | | | | |
| 57. | 16 | 11 | 11 | C6 | TT | 07 | 06 | 10 | 07 | 08 | | | 05 | CM | C5 | 02 | | | | |
| | 15 | 11 | 11 | C5 | CM | 07 | 07 | 10 | 07 | 09 | | | 05 | C3 | 05 | TT | | | | |
| 58. | PO | 07 | 15 | PU | 18 | PM | 00 | DI | PI | DI | | | 01 | DO | | | | | | |
| | PU | 08 | 15 | PU | 18 | PM | 00 | DI | PI | DI | | | | | | | | | | |
| 59. | 18 | 09 | PI | CO | 14 | 10 | 14 | 00 | 21 | 12 | | | | | | | | | | |
| | 17 | 08 | PI | CO | 14 | 15 | 13 | 00 | 21 | 14 | | | | | | | | | | |
| 60. | AA | AA | AA | AA | AA | AA | AA | AA | AA | TT | | | 04 | TT | 10 | 02 | | | | |
| | AA | AA | AA | TT | AA | AA | AA | AA | AA | TT | | | 01 | TT | 04 | AA | 05 | TT | 10 | 02 |
| 61. | 17 | SR | C5 | 12 | 10 | 15 | TT | C2 | 14 | 09 | | | 07 | RR | 08 | TT | | | | |
| | 17 | TT | C5 | 11 | 10 | 14 | TT | C1 | 14 | 09 | | | 02 | SR | 07 | 52 | | | | |
| 62. | DM | 55 | TT | PM | PU | 08 | 52 | C2 | C4 | 16 | | | | | | | | | | |
| | DM | 56 | TT | PM | PU | C7 | 53 | C2 | C4 | 17 | | | 02 | XM | | | | | | |
| 63. | 23 | 17 | 19 | 18 | 20 | 14 | 12 | 21 | 19 | 17 | | | | | | | | | | |
| | 21 | 16 | 19 | 17 | 20 | 10 | 14 | 19 | 19 | 16 | | | | | | | | | | |
| 64. | PU | XM | 13 | PO | 12 | PM | 54 | 11 | 19 | 16 | | | 02 | XO | | | | | | |
| | PO | XU | 12 | PO | 12 | PM | 54 | 11 | 18 | 14 | | | 02 | XM | | | | | | |
| 65. | PO | C9 | TT | C6 | 11 | PU | AA | AA | TT | 03 | | | 07 | TT | | | | | | |
| | PO | C9 | TT | C6 | 12 | PU | AA | AA | TT | 02 | | | 03 | C3 | 07 | TT | | | | |
| 66. | PM | PI | 11 | CO | 14 | PI | PI | 10 | 17 | 14 | | | 04 | PU | | | | | | |
| | PM | PI | 12 | CO | 13 | PI | PI | 11 | 16 | 13 | | | | | | | | | | |
| 67. | DO | 02 | 11 | C3 | 10 | 22 | C2 | C2 | C3 | 16 | | | 02 | TT | 08 | TT | | | | |
| | DU | TT | 11 | C4 | 10 | 21 | C2 | C2 | C3 | 15 | | | 02 | U1 | 06 | TT | | | | |
| 68. | 21 | 15 | 12 | CO | PM | 16 | PO | 13 | CI | 15 | | | 10 | CI | | | | | | |
| | 20 | 16 | 12 | CO | PM | 16 | PU | 13 | CI | 14 | | | 05 | PI | | | | | | |
| 69. | 18 | TT | C1 | C6 | 10 | 14 | C6 | 12 | 03 | 26 | | | 02 | 01 | 09 | TT | | | | |
| | 18 | TT | C9 | C5 | 14 | C6 | 12 | C5 | 21 | | | | | | | | | | | |
| 70. | PO | PM | 16 | PI | 16 | 27 | PI | 20 | CI | 17 | | | 04 | PM | | | | | | |
| | PO | PM | 16 | PI | 16 | 22 | PI | 18 | CI | 17 | | | | | | | | | | |
| 71. | 13 | 61 | 10 | 10 | 10 | 16 | 12 | 14 | 11 | 09 | | | | | | | | | | |
| | 12 | 61 | 11 | 10 | 08 | 14 | 11 | 13 | 15 | 09 | | | 02 | DI | | | | | | |
| 72. | PO | SR | C5 | 20 | 16 | PI | PO | 07 | 18 | 13 | | | | | | | | | | |
| | PU | SR | C4 | 19 | 14 | PI | PU | 07 | 18 | 12 | | | | | | | | | | |

B-23

| | ACIC CODES | | | | | | | | | | REFERENCES | | | | | | | | | | | | | | | | | |
|-----|------------|----|----|----|----|----|----|----|----|----|------------|---|---|---|---|---|---|---|---|---|---|---|---|---|---|---|--|--|
| | 1 | 2 | 3 | 4 | 5 | 6 | 7 | 8 | 9 | 10 | F | R | F | R | F | R | F | R | F | R | F | R | F | R | F | R | | |
| 72. | 15 | 15 | 19 | 15 | 15 | 15 | 15 | 15 | 15 | 15 | | | | | | | | | | | | | | | | | | |
| | 14 | 11 | 14 | 12 | 12 | 12 | 12 | 12 | 12 | 12 | | | | | | | | | | | | | | | | | | |
| 74. | 02 | AA | 10 | 02 | 14 | AA | AA | AA | 16 | 09 | | | | | | | | | | | | | | | | | | |
| | 04 | AA | 10 | 11 | 14 | AA | 12 | AA | 17 | 00 | | | | | | | | | | | | | | | | | | |
| 75. | 18 | 14 | 14 | 10 | 11 | 15 | 15 | 14 | 11 | 09 | | | | | | | | | | | | | | | | | | |
| | 18 | 14 | 14 | 10 | 12 | 15 | 15 | 17 | 11 | 12 | | | | | | | | | | | | | | | | | | |
| 76. | 14 | 15 | 11 | 15 | 14 | 11 | 11 | 11 | 14 | 14 | | | | | | | | | | | | | | | | | | |
| | 14 | 15 | 11 | 14 | 15 | 11 | 11 | 11 | 15 | 15 | | | | | | | | | | | | | | | | | | |
| 77. | PM | 16 | 18 | 11 | 14 | 14 | 14 | 14 | 14 | 18 | | | | | | | | | | | | | | | | | | |
| | PM | 16 | 18 | 11 | 17 | 15 | 14 | 15 | 10 | 16 | | | | | | | | | | | | | | | | | | |
| 78. | 02 | AA | AA | 07 | 05 | AA | AA | AA | 14 | 04 | | | | | | | | | | | | | | | | | | |
| | 05 | AA | AA | 17 | 05 | AA | AA | AA | 04 | 04 | | | | | | | | | | | | | | | | | | |
| 79. | 58 | AA | AA | AA | 04 | AA | AA | AA | AA | AA | | | | | | | | | | | | | | | | | | |
| | 58 | AA | AA | AA | 04 | AA | AA | AA | AA | AA | | | | | | | | | | | | | | | | | | |
| 80. | 14 | 11 | 01 | 00 | 19 | 01 | 11 | 12 | SK | 20 | | | | | | | | | | | | | | | | | | |
| | 14 | 12 | 01 | 00 | 19 | 01 | 11 | 12 | SK | 20 | | | | | | | | | | | | | | | | | | |
| 81. | 16 | AA | 11 | AA | 07 | 01 | AA | AA | 02 | 06 | | | | | | | | | | | | | | | | | | |
| | 16 | AA | 11 | AA | 07 | 01 | 11 | AA | 01 | 06 | | | | | | | | | | | | | | | | | | |
| 82. | 19 | 03 | 07 | 05 | 07 | 20 | 51 | 51 | 04 | 06 | | | | | | | | | | | | | | | | | | |
| | 18 | 03 | 06 | 05 | 08 | 17 | 51 | 11 | 03 | 06 | | | | | | | | | | | | | | | | | | |
| 83. | 20 | 12 | 19 | 01 | 15 | 15 | 01 | 20 | 11 | 15 | | | | | | | | | | | | | | | | | | |
| | 20 | 12 | 19 | 01 | 15 | 15 | 01 | 21 | 11 | 14 | | | | | | | | | | | | | | | | | | |
| 84. | 11 | 05 | 02 | 14 | 11 | 17 | 06 | 14 | 17 | 16 | | | | | | | | | | | | | | | | | | |
| | 11 | 05 | 01 | 14 | 17 | 17 | 06 | 14 | 19 | 16 | | | | | | | | | | | | | | | | | | |
| 85. | 20 | 11 | 16 | 21 | 10 | 12 | 00 | 16 | 20 | 22 | | | | | | | | | | | | | | | | | | |
| | 21 | 11 | 15 | 23 | 10 | 13 | 00 | 16 | 21 | 22 | | | | | | | | | | | | | | | | | | |
| 86. | 10 | 01 | 11 | 00 | 13 | 01 | 16 | 18 | 14 | 16 | | | | | | | | | | | | | | | | | | |
| | 10 | 01 | 11 | 00 | 14 | 01 | 17 | 17 | 14 | 16 | | | | | | | | | | | | | | | | | | |
| 87. | 22 | 57 | 05 | 06 | 07 | 01 | 04 | 05 | 06 | 05 | | | | | | | | | | | | | | | | | | |
| | 22 | 55 | 03 | 06 | 06 | 01 | 03 | 04 | 06 | 05 | | | | | | | | | | | | | | | | | | |
| 88. | 10 | 11 | 10 | 10 | 07 | 01 | 12 | 13 | 11 | 14 | | | | | | | | | | | | | | | | | | |
| | 10 | 11 | 10 | 10 | 07 | 11 | 14 | 13 | 11 | 15 | | | | | | | | | | | | | | | | | | |
| 89. | 21 | 15 | 01 | 17 | 14 | 01 | 10 | 11 | 14 | 15 | | | | | | | | | | | | | | | | | | |
| | 23 | 15 | 11 | 14 | 01 | 10 | 12 | 16 | 14 | | | | | | | | | | | | | | | | | | | |

B-24

| | ACIC CODES | | | | | | | | | | REFERENCES | | | | | | | | | | | | | | | | | |
|------|------------|----|----|----|----|----|----|----|----|----|------------|---|---|---|---|---|---|---|---|---|---|---|---|---|---|---|--|--|
| | 1 | 2 | 3 | 4 | 5 | 6 | 7 | 8 | 9 | 10 | F | R | F | R | F | R | F | R | F | R | F | R | F | R | F | R | | |
| 91. | 10 | 11 | 10 | 11 | 19 | 01 | 11 | 11 | 11 | 11 | | | | | | | | | | | | | | | | | | |
| | 00 | 11 | 10 | 11 | 18 | 01 | 11 | 11 | 11 | 11 | | | | | | | | | | | | | | | | | | |
| 92. | 16 | 11 | 03 | 06 | 05 | 12 | 11 | 11 | 06 | 11 | | | | | | | | | | | | | | | | | | |
| | 17 | 11 | 02 | 05 | 06 | 12 | 11 | 11 | 02 | 11 | | | | | | | | | | | | | | | | | | |
| 93. | 10 | 01 | 11 | 10 | 18 | 01 | 11 | 10 | 21 | 16 | | | | | | | | | | | | | | | | | | |
| | 10 | 01 | 11 | 10 | 19 | 01 | 11 | 10 | 21 | 16 | | | | | | | | | | | | | | | | | | |
| 94. | 17 | 17 | 15 | 20 | 12 | 15 | 14 | 15 | 21 | 10 | | | | | | | | | | | | | | | | | | |
| | 17 | 17 | 15 | 19 | 15 | 15 | 14 | 15 | 21 | 10 | | | | | | | | | | | | | | | | | | |
| 95. | 10 | 11 | 11 | 10 | 12 | 11 | 10 | 10 | 11 | 15 | | | | | | | | | | | | | | | | | | |
| | 10 | 11 | 11 | 10 | 13 | 11 | 10 | 10 | 11 | 14 | | | | | | | | | | | | | | | | | | |
| 96. | 10 | 05 | 12 | 14 | 18 | 01 | 01 | 07 | 13 | 14 | | | | | | | | | | | | | | | | | | |
| | 00 | 05 | 12 | 14 | 18 | 01 | 01 | 07 | 14 | 18 | | | | | | | | | | | | | | | | | | |
| 97. | 19 | 13 | 01 | 04 | 15 | 11 | 53 | 13 | 06 | 06 | | | | | | | | | | | | | | | | | | |
| | 19 | 14 | 02 | 04 | 14 | 12 | 53 | 13 | 06 | 07 | | | | | | | | | | | | | | | | | | |
| 98. | 20 | 10 | 19 | 11 | 11 | 11 | 13 | 08 | 11 | 11 | | | | | | | | | | | | | | | | | | |
| | 20 | 10 | 19 | 11 | 11 | 11 | 13 | 11 | 11 | 11 | | | | | | | | | | | | | | | | | | |
| 99. | 22 | 01 | 08 | 08 | 22 | 16 | 14 | 04 | 07 | 13 | | | | | | | | | | | | | | | | | | |
| | 21 | 01 | 08 | 08 | 21 | 15 | 14 | 05 | 07 | 17 | | | | | | | | | | | | | | | | | | |
| 100. | 17 | 11 | 12 | 15 | 12 | 19 | 56 | 14 | 14 | 09 | | | | | | | | | | | | | | | | | | |
| | 17 | 11 | 12 | 15 | 13 | 19 | 56 | 12 | 12 | 10 | | | | | | | | | | | | | | | | | | |

B-25

| I | N C I C C O D E S | | | | | | | | | | R E F E R E N C E S | | | | | | | | | | | |
|-----|-------------------|----|----|----|----|----|----|----|----|----|---------------------|----|----|----|---|---|---|---|---|---|---|---|
| | 1 | 2 | 3 | 4 | 5 | 6 | 7 | 8 | 9 | 10 | F | R | F | R | F | R | F | R | F | R | F | R |
| 1. | 17 | ic | 14 | 17 | 07 | 10 | 08 | 13 | 15 | 11 | | | | | | | | | | | | |
| | 18 | 11 | 13 | 16 | 04 | 09 | 07 | 15 | 16 | 11 | | | | | | | | | | | | |
| 2. | 21 | 12 | 14 | 15 | 17 | 11 | 14 | 11 | 15 | 12 | | | | | | | | | | | | |
| | 21 | 11 | 15 | 16 | 15 | 16 | 12 | 09 | 14 | 12 | | | | | | | | | | | | |
| 3. | PU | 04 | 10 | 14 | 07 | PM | CM | 07 | 14 | 03 | | | | | | | | | | | | |
| | PG | 04 | 10 | 15 | 08 | PM | CM | 08 | 14 | 03 | 06 | PI | | | | | | | | | | |
| 4. | FU | C1 | 21 | PI | 20 | XX | PM | 17 | CI | 15 | | | | | | | | | | | | |
| | FC | PI | 14 | PI | SR | SK | PM | 16 | PI | 16 | 02 | C1 | 09 | C1 | | | | | | | | |
| 5. | PO | PM | 10 | PO | 00 | PI | PM | PI | PI | 16 | | | | | | | | | | | | |
| | PU | PM | 11 | PO | 00 | PI | PI | PI | PI | 15 | | | | | | | | | | | | |
| 6. | PO | PI | 00 | FU | 13 | PI | PU | PM | CI | 14 | | | | | | | | | | | | |
| | GU | PI | 00 | PU | 13 | DI | PU | PM | CI | 13 | 06 | PI | | | | | | | | | | |
| 7. | 19 | PM | 16 | FU | PG | 12 | PI | PI | PI | 15 | | | | | | | | | | | | |
| | 18 | PM | 16 | PU | PG | 12 | PI | PU | PI | 17 | | | | | | | | | | | | |
| 8. | 21 | G2 | 13 | 00 | 05 | 12 | 55 | 10 | 18 | 12 | | | | | | | | | | | | |
| | 25 | C2 | 15 | 00 | 05 | 12 | 55 | 12 | 15 | 12 | | | | | | | | | | | | |
| 9. | 22 | 16 | 14 | 23 | 16 | DI | 05 | 05 | 05 | 16 | | | | | | | | | | | | |
| | 21 | 14 | 15 | 22 | 16 | DI | 04 | 05 | 07 | 19 | | | | | | | | | | | | |
| 10. | PU | 58 | 01 | 00 | 14 | C1 | PO | 02 | 04 | 14 | | | | | | | | | | | | |
| | PU | 58 | 11 | 00 | 14 | C1 | PU | 11 | 04 | 13 | 03 | 01 | | | | | | | | | | |
| 11. | 10 | 09 | 14 | 18 | 15 | 07 | 10 | 14 | 13 | 13 | | | | | | | | | | | | |
| | 10 | 10 | 12 | 19 | 13 | 07 | 12 | 14 | 16 | 12 | | | | | | | | | | | | |
| 12. | 00 | 15 | 03 | 10 | 06 | DI | 11 | 12 | 13 | 16 | | | | | | | | | | | | |
| | 00 | 12 | 03 | 11 | 06 | DI | 11 | 12 | 12 | 13 | | | | | | | | | | | | |
| 13. | PM | 00 | 14 | 00 | 12 | PM | PM | CI | PI | CI | | | | | | | | | | | | |
| | PM | 00 | 12 | 00 | 12 | PI | PM | 15 | PI | CI | 08 | CI | | | | | | | | | | |
| 14. | 13 | PU | 12 | 10 | 14 | PM | PU | 06 | 10 | 11 | | | | | | | | | | | | |
| | 14 | PM | 12 | 11 | 14 | PM | PU | 05 | 09 | 11 | | | | | | | | | | | | |
| 15. | DM | AA | AA | 11 | 09 | 65 | AA | 01 | 11 | 08 | | | | | | | | | | | | |
| | DM | AA | AA | 11 | 10 | 64 | AA | 01 | 11 | 08 | | | | | | | | | | | | |
| 16. | PI | 17 | 12 | 21 | 17 | 13 | 09 | 16 | 21 | 15 | | | | | | | | | | | | |
| | PI | 14 | 14 | 20 | 19 | 12 | 09 | 17 | 21 | 15 | | | | | | | | | | | | |
| 17. | XX | XX | XX | XX | XX | 18 | 11 | G3 | 08 | 16 | | | | | | | | | | | | |
| | XX | XX | XX | XX | XX | 17 | 11 | G3 | 08 | 15 | | | | | | | | | | | | |

B-26

| I | N C I C C O D E S | | | | | | | | | | R E F E R E N C E S | | | | | | | | | | | |
|-----|-------------------|----|----|----|----|----|----|----|----|----|---------------------|----|----|----|----|----|----|----|---|---|---|---|
| | 1 | 2 | 3 | 4 | 5 | 6 | 7 | 8 | 9 | 10 | F | R | F | R | F | R | F | R | F | R | F | R |
| 19. | 13 | 09 | 04 | PM | 11 | 12 | 05 | 06 | PI | 02 | | | | | | | | | | | | |
| | 15 | 10 | 04 | PU | 11 | 15 | 06 | 07 | PI | 02 | 04 | PM | | | | | | | | | | |
| 20. | PI | 07 | CI | 14 | 17 | PI | 00 | 11 | 14 | 14 | | | | | | | | | | | | |
| | PI | 05 | CI | 17 | 16 | PI | 00 | 11 | 14 | 14 | | | | | | | | | | | | |
| 21. | PI | PM | 00 | PU | SR | PM | PM | SR | 16 | 14 | | | | | | | | | | | | |
| | PI | PM | 00 | PU | SR | PM | PM | SR | 17 | 15 | 02 | PI | 04 | PU | 06 | CI | 08 | 11 | | | | |
| 22. | 00 | 09 | 00 | PO | 14 | DI | 00 | PM | PI | 16 | | | | | | | | | | | | |
| | 00 | 09 | 00 | PO | 13 | DI | 00 | PI | 01 | 15 | 04 | CO | 06 | PI | 07 | X0 | 08 | PM | | | | |
| 23. | 15 | 02 | 12 | 15 | 06 | 14 | 51 | 04 | 12 | 05 | | | | | | | | | | | | |
| | 16 | 03 | 14 | 15 | 05 | 13 | 53 | 06 | 13 | 04 | 03 | SR | | | | | | | | | | |
| 24. | 13 | SR | 13 | 13 | 13 | 13 | 13 | SK | 13 | 13 | | | | | | | | | | | | |
| | 13 | SE | 13 | 14 | 13 | 13 | 13 | SR | 12 | 12 | 02 | SR | 08 | 17 | | | | | | | | |
| 25. | SK | 06 | 02 | 14 | 11 | 04 | 05 | 11 | 16 | 11 | | | | | | | | | | | | |
| | CO | 07 | 04 | 14 | 11 | 06 | 04 | 11 | 57 | 11 | CI | XU | | | | | | | | | | |
| 26. | 21 | 11 | 14 | 23 | 07 | 10 | 06 | 11 | 14 | 12 | | | | | | | | | | | | |
| | 22 | 11 | 14 | 23 | 05 | 15 | 06 | 10 | 14 | 09 | | | | | | | | | | | | |
| 27. | 15 | AA | CI | 06 | 01 | G2 | AA | 01 | 08 | 05 | | | | | | | | | | | | |
| | 15 | AA | 11 | 08 | 01 | G2 | AA | 01 | 08 | 05 | 05 | CI | | | | | | | | | | |
| 28. | 16 | PI | PI | SR | 14 | 19 | PG | 13 | CI | 12 | | | | | | | | | | | | |
| | 19 | PI | PI | SR | 15 | 16 | PG | 13 | PI | 13 | 04 | 16 | 06 | DI | | | | | | | | |
| 29. | 25 | PI | 16 | 23 | 20 | 24 | PO | PI | 22 | 18 | | | | | | | | | | | | |
| | 25 | PI | 18 | 21 | 20 | 22 | PC | PI | 21 | 19 | 09 | 22 | 09 | 23 | | | | | | | | |
| 30. | 14 | 00 | 08 | 13 | 09 | 14 | 06 | 12 | 15 | 11 | | | | | | | | | | | | |
| | 15 | 00 | 08 | 15 | 10 | 15 | 06 | 14 | 16 | 11 | | | | | | | | | | | | |
| 31. | 14 | 55 | 11 | 03 | 09 | 12 | 52 | 03 | 05 | SK | | | | | | | | | | | | |
| | 14 | 55 | 11 | 02 | 10 | 11 | 52 | 03 | 04 | 08 | 10 | SK | | | | | | | | | | |
| 32. | 05 | 05 | AA | 09 | 05 | 04 | 60 | AA | 12 | 05 | | | | | | | | | | | | |
| | 07 | 05 | AA | 09 | 06 | 05 | 62 | AA | 15 | 06 | | | | | | | | | | | | |
| 33. | 04 | 02 | 04 | 05 | 09 | 05 | 11 | SK | 05 | 11 | | | | | | | | | | | | |
| | 03 | 03 | 05 | 05 | 10 | 06 | 11 | SK | 06 | 10 | 08 | 02 | | | | | | | | | | |
| 34. | AA | AA | 09 | 17 | 08 | AA | AA | 09 | 15 | 04 | | | | | | | | | | | | |
| | AA | AA | 10 | 17 | 10 | AA | AA | 10 | 13 | 05 | 04 | SK | | | | | | | | | | |
| 35. | 00 | 13 | 13 | PM | 10 | DI | 15 | 12 | PI | 12 | | | | | | | | | | | | |
| | 00 | 13 | 14 | PM | 11 | PI | 13 | 14 | PI | 10 | | | | | | | | | | | | |
| 36. | PI | PI | 13 | 20 | 14 | SK | PM | 11 | 17 | 16 | | | | | | | | | | | | |
| | PI | PI | 11 | 19 | 16 | PI | PM | 13 | 20 | 16 | 06 | SK | | | | | | | | | | |

B-27

1 2 3 4 5 6 7 8 9 10 REFERENCE

| | | | | | | | | | | | | | | | | | | |
|-----|----|----|----|----|----|----|----|----|----|----|----|----|----|----|----|----|----|----|
| 37. | PO | 03 | 18 | 00 | 01 | 02 | 03 | 04 | 05 | 06 | 07 | 08 | 09 | 10 | 04 | 00 | 10 | CI |
| 38. | PO | 04 | 19 | 01 | 02 | 03 | 04 | 05 | 06 | 07 | 08 | 09 | 10 | 11 | 05 | 00 | 11 | CI |
| 39. | PO | 05 | 20 | 02 | 03 | 04 | 05 | 06 | 07 | 08 | 09 | 10 | 11 | 12 | 06 | 00 | 12 | CI |
| 40. | PO | 06 | 21 | 03 | 04 | 05 | 06 | 07 | 08 | 09 | 10 | 11 | 12 | 13 | 07 | 00 | 13 | CI |
| 41. | PO | 07 | 22 | 04 | 05 | 06 | 07 | 08 | 09 | 10 | 11 | 12 | 13 | 14 | 08 | 00 | 14 | CI |
| 42. | PO | 08 | 23 | 05 | 06 | 07 | 08 | 09 | 10 | 11 | 12 | 13 | 14 | 15 | 09 | 00 | 15 | CI |
| 43. | PO | 09 | 24 | 06 | 07 | 08 | 09 | 10 | 11 | 12 | 13 | 14 | 15 | 16 | 10 | 00 | 16 | CI |
| 44. | PO | 10 | 25 | 07 | 08 | 09 | 10 | 11 | 12 | 13 | 14 | 15 | 16 | 17 | 11 | 00 | 17 | CI |
| 45. | PO | 11 | 26 | 08 | 09 | 10 | 11 | 12 | 13 | 14 | 15 | 16 | 17 | 18 | 12 | 00 | 18 | CI |
| 46. | PO | 12 | 27 | 09 | 10 | 11 | 12 | 13 | 14 | 15 | 16 | 17 | 18 | 19 | 13 | 00 | 19 | CI |
| 47. | PO | 13 | 28 | 10 | 11 | 12 | 13 | 14 | 15 | 16 | 17 | 18 | 19 | 20 | 14 | 00 | 20 | CI |
| 48. | PO | 14 | 29 | 11 | 12 | 13 | 14 | 15 | 16 | 17 | 18 | 19 | 20 | 21 | 15 | 00 | 21 | CI |
| 49. | PO | 15 | 30 | 12 | 13 | 14 | 15 | 16 | 17 | 18 | 19 | 20 | 21 | 22 | 16 | 00 | 22 | CI |
| 50. | PO | 16 | 31 | 13 | 14 | 15 | 16 | 17 | 18 | 19 | 20 | 21 | 22 | 23 | 17 | 00 | 23 | CI |
| 51. | PO | 17 | 32 | 14 | 15 | 16 | 17 | 18 | 19 | 20 | 21 | 22 | 23 | 24 | 18 | 00 | 24 | CI |
| 52. | PO | 18 | 33 | 15 | 16 | 17 | 18 | 19 | 20 | 21 | 22 | 23 | 24 | 25 | 19 | 00 | 25 | CI |
| 53. | PO | 19 | 34 | 16 | 17 | 18 | 19 | 20 | 21 | 22 | 23 | 24 | 25 | 26 | 20 | 00 | 26 | CI |

1 2 3 4 5 6 7 8 9 10 REFERENCE

| | | | | | | | | | | | | | | | | | | |
|-----|----|----|----|----|----|----|----|----|----|----|----|----|----|----|----|----|----|----|
| 54. | PO | 20 | 35 | 17 | 18 | 19 | 20 | 21 | 22 | 23 | 24 | 25 | 26 | 27 | 21 | 00 | 27 | CI |
| 55. | PO | 21 | 36 | 18 | 19 | 20 | 21 | 22 | 23 | 24 | 25 | 26 | 27 | 28 | 22 | 00 | 28 | CI |
| 56. | PO | 22 | 37 | 19 | 20 | 21 | 22 | 23 | 24 | 25 | 26 | 27 | 28 | 29 | 23 | 00 | 29 | CI |
| 57. | PO | 23 | 38 | 20 | 21 | 22 | 23 | 24 | 25 | 26 | 27 | 28 | 29 | 30 | 24 | 00 | 30 | CI |
| 58. | PO | 24 | 39 | 21 | 22 | 23 | 24 | 25 | 26 | 27 | 28 | 29 | 30 | 31 | 25 | 00 | 31 | CI |
| 59. | PO | 25 | 40 | 22 | 23 | 24 | 25 | 26 | 27 | 28 | 29 | 30 | 31 | 32 | 26 | 00 | 32 | CI |
| 60. | PO | 26 | 41 | 23 | 24 | 25 | 26 | 27 | 28 | 29 | 30 | 31 | 32 | 33 | 27 | 00 | 33 | CI |
| 61. | PO | 27 | 42 | 24 | 25 | 26 | 27 | 28 | 29 | 30 | 31 | 32 | 33 | 34 | 28 | 00 | 34 | CI |
| 62. | PO | 28 | 43 | 25 | 26 | 27 | 28 | 29 | 30 | 31 | 32 | 33 | 34 | 35 | 29 | 00 | 35 | CI |
| 63. | PO | 29 | 44 | 26 | 27 | 28 | 29 | 30 | 31 | 32 | 33 | 34 | 35 | 36 | 30 | 00 | 36 | CI |
| 64. | PO | 30 | 45 | 27 | 28 | 29 | 30 | 31 | 32 | 33 | 34 | 35 | 36 | 37 | 31 | 00 | 37 | CI |
| 65. | PO | 31 | 46 | 28 | 29 | 30 | 31 | 32 | 33 | 34 | 35 | 36 | 37 | 38 | 32 | 00 | 38 | CI |
| 66. | PO | 32 | 47 | 29 | 30 | 31 | 32 | 33 | 34 | 35 | 36 | 37 | 38 | 39 | 33 | 00 | 39 | CI |
| 67. | PO | 33 | 48 | 30 | 31 | 32 | 33 | 34 | 35 | 36 | 37 | 38 | 39 | 40 | 34 | 00 | 40 | CI |
| 68. | PO | 34 | 49 | 31 | 32 | 33 | 34 | 35 | 36 | 37 | 38 | 39 | 40 | 41 | 35 | 00 | 41 | CI |
| 69. | PO | 35 | 50 | 32 | 33 | 34 | 35 | 36 | 37 | 38 | 39 | 40 | 41 | 42 | 36 | 00 | 42 | CI |
| 70. | PO | 36 | 51 | 33 | 34 | 35 | 36 | 37 | 38 | 39 | 40 | 41 | 42 | 43 | 37 | 00 | 43 | CI |
| 71. | PO | 37 | 52 | 34 | 35 | 36 | 37 | 38 | 39 | 40 | 41 | 42 | 43 | 44 | 38 | 00 | 44 | CI |
| 72. | PO | 38 | 53 | 35 | 36 | 37 | 38 | 39 | 40 | 41 | 42 | 43 | 44 | 45 | 39 | 00 | 45 | CI |

Exhibit B-3. Fingerprint Code Conversions Used in Sifter

| ALPHANUMERIC CODE (NCIC) | NUMERIC CODE (SIFTER) | MEANING |
|--------------------------|-----------------------|--------------------------------------|
| 1-49 | 1-49 | ulnar loops |
| 51-99 | 51-99 | radial loops |
| AA | 101 | plain arch |
| TT | 102 | tented arch |
| XX | 103 | amputation |
| SR | 104 | scar |
| PI | 105 | plain whorl--inner tracing |
| PM | 106 | plain whorl--meeting tracing |
| PO | 107 | plain whorl--outer tracing |
| CI | 108 | central pocket loop--inner tracing |
| CM | 109 | central pocket loop--meeting tracing |
| CO | 110 | central pocket loop--outer tracing |
| DI | 111 | double loop--inner tracing |
| DM | 112 | double loop--meeting tracing |
| DO | 113 | double loop--outer tracing |
| XI | 114 | accidental whorl--inner tracing |
| XM | 115 | accidental whorl--meeting tracing |
| XO | 116 | accidental whorl--outer tracing |

Exhibit B-4. Sifter-Number Flow Chart

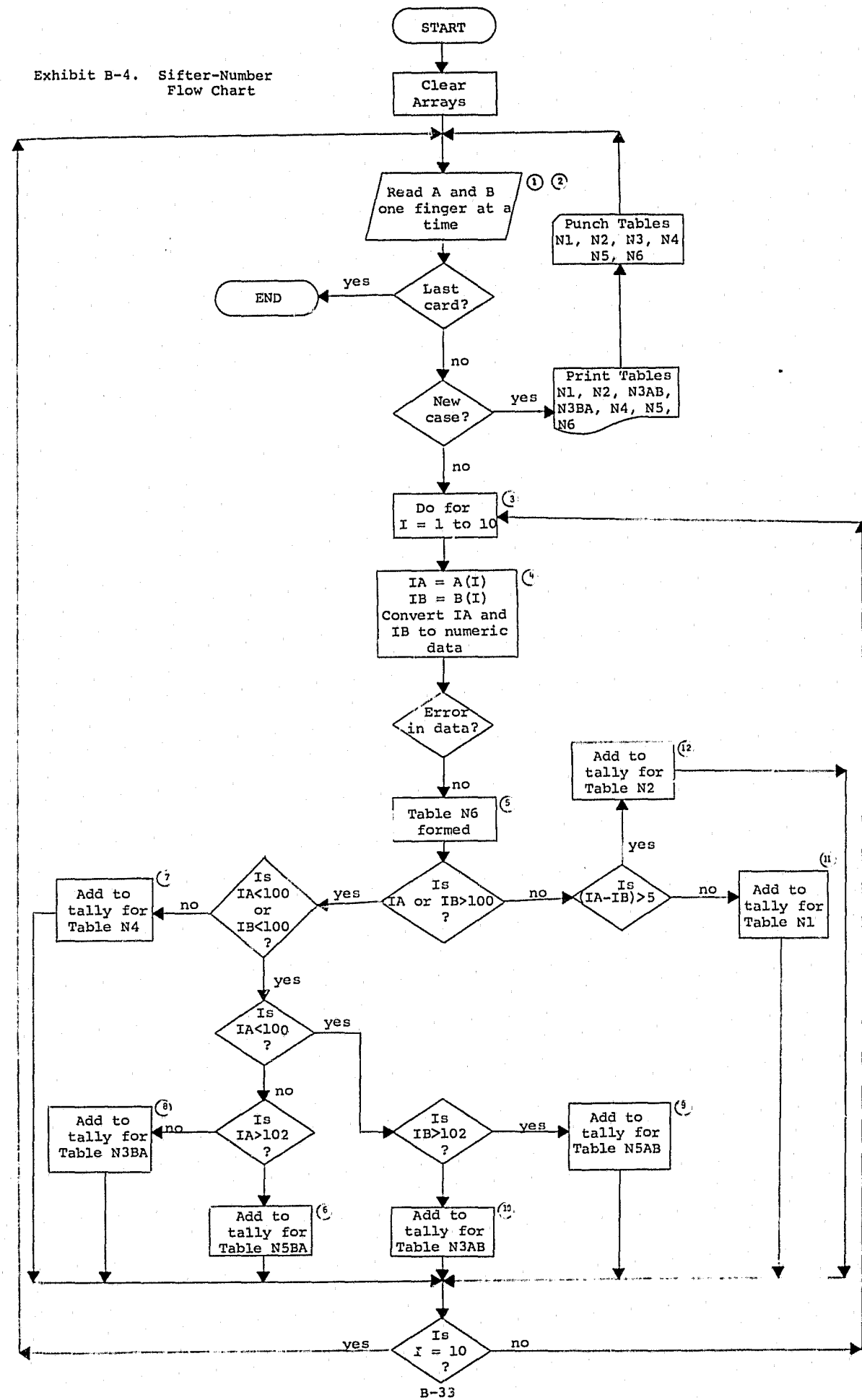

NOTES ON FLOWCHART

- (1) (2) A, B pair of codes of matching fingerprint cards, 10 fingers/card = > A(1) - A(10), alphanumeric data.
- (3) I number of finger being considered
- (4) IA = A(I) set IA equal to the count of the finger being considered. Similarly for IB.
- (5) N6 Table 6, total count for each fingerprint code on A cards and B cards
- (6) 5BA see IDENT tables, Table N5BA
- (7) 4 see IDENT tables, Table 4
- (8) 3BA see IDENT tables, Table N3BA
- (9) 5AB see IDENT tables, Table N5AB
- (10) 3AB see IDENT tables, Table N3AB
- (11) 1 see IDENT tables, Table 1
- (12) 2 see IDENT tables, Table 2

Exhibit B-4 (Continued). SIFTER-NUMER Flowchart

*** PSIUFNIZ ***
 ** (A-B) **

| *A* | -5 | -4 | -3 | -2 | -1 | 0 | 1 | 2 | 3 | 4 | 5 | TOTAL |
|-----|----|----|----|----|----|----|----|----|---|---|---|-------|
| 1 | 0 | 0 | 0 | 0 | 2 | 6 | 5 | 0 | 0 | 0 | 0 | 39 |
| 2 | 0 | 0 | 0 | 0 | 11 | 19 | 13 | 0 | 0 | 0 | 0 | 55 |
| 3 | 0 | 0 | 2 | 3 | 12 | 25 | 11 | 0 | 0 | 0 | 0 | 67 |
| 4 | 0 | 0 | 0 | 6 | 21 | 29 | 15 | 1 | 0 | 0 | 0 | 76 |
| 5 | 0 | 0 | 3 | 5 | 21 | 31 | 10 | 4 | 0 | 0 | 0 | 71 |
| 6 | 1 | 1 | 0 | 10 | 16 | 28 | 16 | 0 | 0 | 0 | 0 | 87 |
| 7 | 1 | 0 | 1 | 8 | 25 | 30 | 16 | 0 | 0 | 0 | 0 | 85 |
| 8 | 1 | 0 | 2 | 8 | 19 | 43 | 10 | 2 | 0 | 0 | 0 | 115 |
| 9 | 1 | 0 | 2 | 13 | 29 | 43 | 18 | 4 | 0 | 1 | 0 | 119 |
| 10 | 0 | 2 | 7 | 7 | 32 | 42 | 25 | 3 | 1 | 0 | 0 | 141 |
| 11 | 2 | 3 | 4 | 13 | 38 | 51 | 25 | 5 | 0 | 0 | 0 | 140 |
| 12 | 0 | 1 | 5 | 15 | 30 | 55 | 25 | 7 | 2 | 0 | 0 | 145 |
| 13 | 0 | 2 | 10 | 16 | 30 | 36 | 31 | 14 | 5 | 0 | 1 | 132 |
| 14 | 0 | 1 | 2 | 17 | 19 | 44 | 25 | 14 | 4 | 1 | 0 | 118 |
| 15 | 0 | 1 | 5 | 13 | 30 | 33 | 24 | 12 | 4 | 2 | 0 | 87 |
| 16 | 0 | 2 | 3 | 12 | 23 | 36 | 21 | 16 | 4 | 1 | 0 | 61 |
| 17 | 1 | 2 | 8 | 8 | 23 | 28 | 13 | 10 | 2 | 0 | 0 | 49 |
| 18 | 0 | 0 | 2 | 2 | 17 | 14 | 9 | 13 | 3 | 0 | 0 | 40 |
| 19 | 0 | 0 | 0 | 3 | 7 | 19 | 10 | 5 | 3 | 0 | 0 | 26 |
| 20 | 0 | 0 | 1 | 0 | 10 | 15 | 7 | 4 | 1 | 0 | 0 | 21 |
| 21 | 0 | 0 | 0 | 1 | 4 | 7 | 7 | 7 | 1 | 1 | 0 | 12 |
| 22 | 0 | 0 | 0 | 2 | 2 | 2 | 1 | 4 | 0 | 1 | 0 | 11 |
| 23 | 0 | 0 | 1 | 1 | 2 | 2 | 3 | 3 | 2 | 0 | 0 | 2 |
| 24 | 0 | 0 | 0 | 0 | 0 | 3 | 0 | 0 | 0 | 0 | 0 | 1 |
| 25 | 0 | 0 | 0 | 1 | 1 | 0 | 0 | 0 | 0 | 0 | 0 | 3 |
| 26 | 0 | 0 | 0 | 0 | 0 | 2 | 0 | 0 | 0 | 0 | 0 | 2 |
| 27 | 0 | 0 | 0 | 0 | 0 | 0 | 0 | 0 | 0 | 0 | 0 | 1 |
| 28 | 0 | 0 | 1 | 0 | 0 | 1 | 0 | 0 | 0 | 0 | 0 | 3 |
| 29 | 0 | 0 | 0 | 0 | 0 | 0 | 0 | 0 | 0 | 0 | 0 | 1 |
| 30 | 0 | 0 | 0 | 0 | 0 | 0 | 0 | 0 | 0 | 0 | 0 | 0 |
| 31 | 0 | 0 | 0 | 0 | 0 | 0 | 0 | 0 | 0 | 0 | 0 | 0 |
| 32 | 0 | 0 | 0 | 0 | 0 | 0 | 0 | 0 | 0 | 0 | 0 | 0 |
| 33 | 0 | 0 | 0 | 0 | 0 | 0 | 0 | 0 | 0 | 0 | 0 | 0 |
| 34 | 0 | 0 | 0 | 0 | 0 | 0 | 0 | 0 | 0 | 0 | 0 | 0 |
| 35 | 0 | 0 | 0 | 0 | 0 | 0 | 0 | 0 | 0 | 0 | 0 | 0 |
| 36 | 0 | 0 | 0 | 0 | 0 | 0 | 0 | 0 | 0 | 0 | 0 | 0 |
| 37 | 0 | 0 | 0 | 0 | 0 | 0 | 0 | 0 | 0 | 0 | 0 | 0 |
| 38 | 0 | 0 | 0 | 0 | 0 | 0 | 0 | 0 | 0 | 0 | 0 | 0 |
| 39 | 0 | 0 | 0 | 0 | 0 | 0 | 0 | 0 | 0 | 0 | 0 | 0 |
| 40 | 0 | 0 | 0 | 0 | 0 | 0 | 0 | 0 | 0 | 0 | 0 | 0 |
| 41 | 0 | 0 | 0 | 0 | 0 | 0 | 0 | 0 | 0 | 0 | 0 | 0 |
| 42 | 0 | 0 | 0 | 0 | 0 | 0 | 0 | 0 | 0 | 0 | 0 | 0 |
| 43 | 0 | 0 | 0 | 0 | 0 | 0 | 0 | 0 | 0 | 0 | 0 | 0 |
| 44 | 0 | 0 | 0 | 0 | 0 | 0 | 0 | 0 | 0 | 0 | 0 | 0 |
| 45 | 0 | 0 | 0 | 0 | 0 | 0 | 0 | 0 | 0 | 0 | 0 | 0 |
| 46 | 0 | 0 | 0 | 0 | 0 | 0 | 0 | 0 | 0 | 0 | 0 | 0 |
| 47 | 0 | 0 | 0 | 0 | 0 | 0 | 0 | 0 | 0 | 0 | 0 | 0 |
| 48 | 0 | 0 | 0 | 0 | 0 | 0 | 0 | 0 | 0 | 0 | 0 | 0 |
| 49 | 0 | 0 | 0 | 0 | 0 | 0 | 0 | 0 | 0 | 0 | 0 | 0 |
| 50 | 0 | 0 | 0 | 0 | 0 | 0 | 0 | 0 | 0 | 0 | 0 | 0 |
| 51 | 0 | 0 | 0 | 0 | 0 | 0 | 0 | 0 | 0 | 0 | 0 | 0 |
| 52 | 0 | 0 | 0 | 0 | 0 | 0 | 0 | 0 | 0 | 0 | 0 | 0 |
| 53 | 0 | 0 | 0 | 0 | 0 | 0 | 0 | 0 | 0 | 0 | 0 | 0 |
| 54 | 0 | 0 | 0 | 2 | 3 | 5 | 3 | 0 | 0 | 0 | 0 | 17 |

| TOTAL COUNT | TOTAL | | | | | | | | | |
|-------------|-------|-----|---|---|---|---|---|---|---|-----|
| | A | 1 | 2 | 3 | 4 | 5 | 6 | 7 | 8 | 9 |
| 1 | 35 | 15 | | | | | | | | 28 |
| 2 | 45 | 25 | | | | | | | | 32 |
| 3 | 56 | 34 | | | | | | | | 110 |
| 4 | 67 | 52 | | | | | | | | 124 |
| 5 | 78 | 61 | | | | | | | | 146 |
| 6 | 71 | 53 | | | | | | | | 131 |
| 7 | 60 | 75 | | | | | | | | 161 |
| 8 | 69 | 102 | | | | | | | | 152 |
| 9 | 116 | 107 | | | | | | | | 218 |
| 10 | 122 | 114 | | | | | | | | 291 |
| 11 | 143 | 144 | | | | | | | | 297 |
| 12 | 141 | 151 | | | | | | | | 262 |
| 13 | 146 | 143 | | | | | | | | 277 |
| 14 | 137 | 147 | | | | | | | | 274 |
| 15 | 124 | 110 | | | | | | | | 244 |
| 16 | 114 | 126 | | | | | | | | 245 |
| 17 | 119 | 87 | | | | | | | | 176 |
| 18 | 64 | 73 | | | | | | | | 137 |
| 19 | 49 | 65 | | | | | | | | 114 |
| 20 | 71 | 36 | | | | | | | | 78 |
| 21 | 26 | 36 | | | | | | | | 62 |
| 22 | 22 | 12 | | | | | | | | 34 |
| 23 | 12 | 9 | | | | | | | | 21 |
| 24 | 11 | 6 | | | | | | | | 19 |
| 25 | 2 | 2 | | | | | | | | 4 |
| 26 | 2 | 2 | | | | | | | | 7 |
| 27 | 1 | 1 | | | | | | | | 2 |
| 28 | 3 | 4 | | | | | | | | 5 |
| 29 | 1 | 1 | | | | | | | | 2 |
| 30 | 1 | 2 | | | | | | | | 3 |
| 31 | 0 | 0 | | | | | | | | 0 |
| 32 | 0 | 0 | | | | | | | | 0 |
| 33 | 0 | 0 | | | | | | | | 0 |
| 34 | 0 | 0 | | | | | | | | 0 |
| 35 | 0 | 0 | | | | | | | | 0 |
| 36 | 0 | 0 | | | | | | | | 0 |
| 37 | 0 | 0 | | | | | | | | 0 |
| 38 | 0 | 0 | | | | | | | | 0 |
| 39 | 0 | 0 | | | | | | | | 0 |
| 40 | 0 | 0 | | | | | | | | 0 |
| 41 | 0 | 0 | | | | | | | | 0 |
| 42 | 0 | 0 | | | | | | | | 0 |
| 43 | 0 | 0 | | | | | | | | 0 |
| 44 | 0 | 0 | | | | | | | | 0 |
| 45 | 0 | 0 | | | | | | | | 0 |
| 46 | 0 | 0 | | | | | | | | 0 |
| 47 | 0 | 0 | | | | | | | | 0 |
| 48 | 0 | 0 | | | | | | | | 0 |

| | | | | | | | | | | |
|-----|-----|-----|--|--|--|--|--|--|--|-----|
| 49 | 10 | 12 | | | | | | | | 19 |
| 50 | 26 | 17 | | | | | | | | 32 |
| 51 | 24 | 18 | | | | | | | | 17 |
| 52 | 2 | 5 | | | | | | | | 8 |
| 53 | 7 | 6 | | | | | | | | 12 |
| 54 | 4 | 4 | | | | | | | | 8 |
| 55 | 3 | 1 | | | | | | | | 4 |
| 56 | 3 | 6 | | | | | | | | 9 |
| 57 | 1 | 4 | | | | | | | | 5 |
| 58 | 6 | 4 | | | | | | | | 10 |
| 59 | 2 | 4 | | | | | | | | 6 |
| 60 | 6 | 5 | | | | | | | | 11 |
| 61 | 6 | 2 | | | | | | | | 8 |
| 62 | 6 | 3 | | | | | | | | 9 |
| 63 | 3 | 9 | | | | | | | | 12 |
| 64 | 0 | 0 | | | | | | | | 0 |
| 65 | 1 | 1 | | | | | | | | 2 |
| 66 | 2 | 1 | | | | | | | | 3 |
| 67 | 2 | 2 | | | | | | | | 4 |
| 68 | 2 | 0 | | | | | | | | 2 |
| 69 | 2 | 0 | | | | | | | | 2 |
| 70 | 2 | 1 | | | | | | | | 3 |
| 71 | 0 | 0 | | | | | | | | 0 |
| 72 | 1 | 0 | | | | | | | | 1 |
| 73 | 0 | 0 | | | | | | | | 0 |
| 74 | 0 | 1 | | | | | | | | 1 |
| 75 | 0 | 0 | | | | | | | | 0 |
| 76 | 0 | 0 | | | | | | | | 0 |
| 77 | 0 | 0 | | | | | | | | 0 |
| 78 | 0 | 0 | | | | | | | | 0 |
| 79 | 0 | 0 | | | | | | | | 0 |
| 80 | 0 | 0 | | | | | | | | 0 |
| 81 | 0 | 0 | | | | | | | | 0 |
| 82 | 0 | 0 | | | | | | | | 0 |
| 83 | 0 | 0 | | | | | | | | 0 |
| 84 | 0 | 0 | | | | | | | | 0 |
| 85 | 0 | 0 | | | | | | | | 0 |
| 86 | 0 | 0 | | | | | | | | 0 |
| 87 | 0 | 0 | | | | | | | | 0 |
| 88 | 0 | 0 | | | | | | | | 0 |
| 89 | 0 | 0 | | | | | | | | 0 |
| 90 | 0 | 0 | | | | | | | | 0 |
| 91 | 0 | 0 | | | | | | | | 0 |
| 92 | 0 | 0 | | | | | | | | 0 |
| 93 | 0 | 0 | | | | | | | | 0 |
| 94 | 0 | 0 | | | | | | | | 0 |
| 95 | 0 | 0 | | | | | | | | 0 |
| 96 | 0 | 0 | | | | | | | | 0 |
| 97 | 0 | 0 | | | | | | | | 0 |
| 98 | 0 | 0 | | | | | | | | 0 |
| 99 | 0 | 0 | | | | | | | | 0 |
| 100 | 0 | 0 | | | | | | | | 0 |
| 101 | 117 | 113 | | | | | | | | 230 |
| 102 | 79 | 91 | | | | | | | | 170 |
| 103 | 5 | 4 | | | | | | | | 9 |
| 104 | 22 | 38 | | | | | | | | 60 |
| 105 | 109 | 174 | | | | | | | | 348 |
| 106 | 100 | 107 | | | | | | | | 207 |
| 107 | 101 | 105 | | | | | | | | 346 |
| 108 | 41 | 37 | | | | | | | | 78 |
| 109 | 5 | 2 | | | | | | | | 7 |
| 110 | 44 | 47 | | | | | | | | 91 |
| 111 | 60 | 57 | | | | | | | | 117 |
| 112 | 2 | 3 | | | | | | | | 5 |

Exhibit B-6. SIFTER-NUMER Normalization Factors

| Table # | Numeric Code | Normalization Factor | Range of Possible X (Choose 1) ¹ |
|-------------------|---------------|----------------------|---|
| N1 | 1-100 | N6 (X) ¹ | 1-100 |
| N2 | 6,7,...13 | N6 (X) | 6-13 |
| | 14-46 | 33*N6 (X) | 14-46 |
| | 47-53 | 7*N6 (X) | 47-53 |
| | 54-100 | 33*N6 (X) | |
| N3AB ² | 1,2,...5 | 2*N6 (X) | 1-5 |
| | | 10 | |
| | 6-10 | 2*Σ N6 (X) X=6 | |
| | | 50 | |
| | 11-50 | 2*Σ N6 (X) X=11 | |
| | 51-55 | 2*N6 (X) | 51-55 |
| | | 60 | |
| | 56-60 | 2*Σ N6 (X) X=56 | |
| | | 100 | |
| | 61-100 | 2*Σ N6 (X) X=61 | |
| N3BA ³ | 1,2,...5 | N6 (X) | 101,102 |
| | 6-10 | 5*N6 (X) | 101,102 |
| | 11-50 | 40*N6 (X) | 101,102 |
| | 51-55 | N6 (X) | 101,102 |
| | 56-60 | 5*N6 (X) | 101,102 |
| | 61-100 | 40*N6 (X) | 101,102 |
| N4 | 101,102...116 | N6 (X) | 101-116 |
| N5AB ² | 1-10 | 10 | |
| | | 2*Σ N6 (X) X=1 | |
| | | 20 | |
| | 11-20 | 2*Σ N6 (X) X=11 | |
| | . | 10 | |
| | 91-100 | 2*Σ N6 (X) X=91 | |
| N5BA ³ | 1-10 | 20*N6 (X) | 103-116 |
| | . | | |
| | 91-100 | 20*N6 (X) | 103-116 |

¹X - see range of possible X values, choose one
²AB indicates A is loop, B is non-loop
³BA indicates B is loop, A is non-loop

Table 5 1

Exhibit B-7. Smoothed and Normalized Numerator Tables (Data Set #2)

Table with 12 columns of numerical data, representing smoothed and normalized numerator tables for various data points.

B-42

Exhibit B-7 (Continued)

Continuation of the table from the previous block, containing 12 columns of numerical data.

B-43

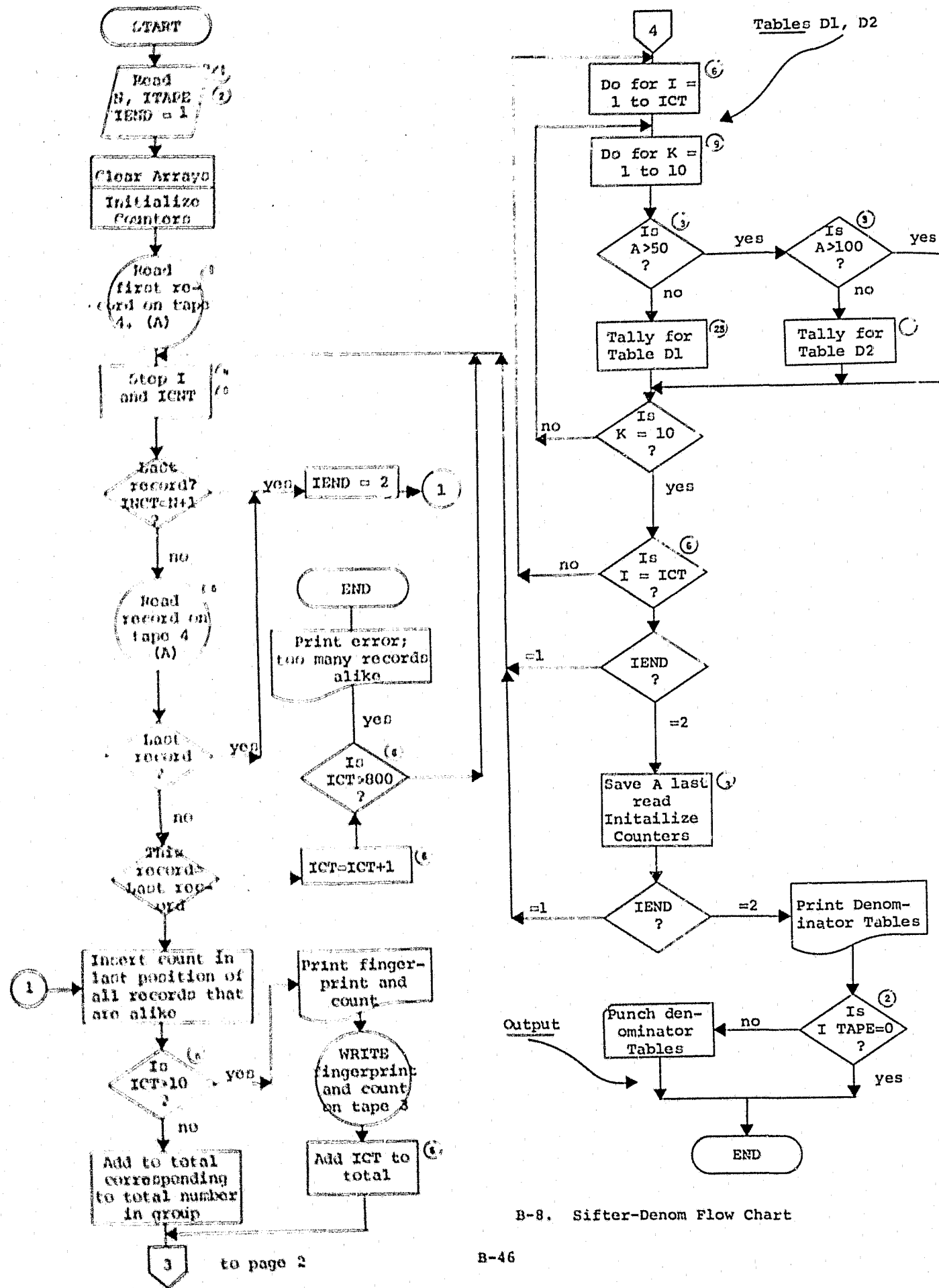

B-8. Sifter-Denom Flow Chart

CONTINUED

1 OF 2

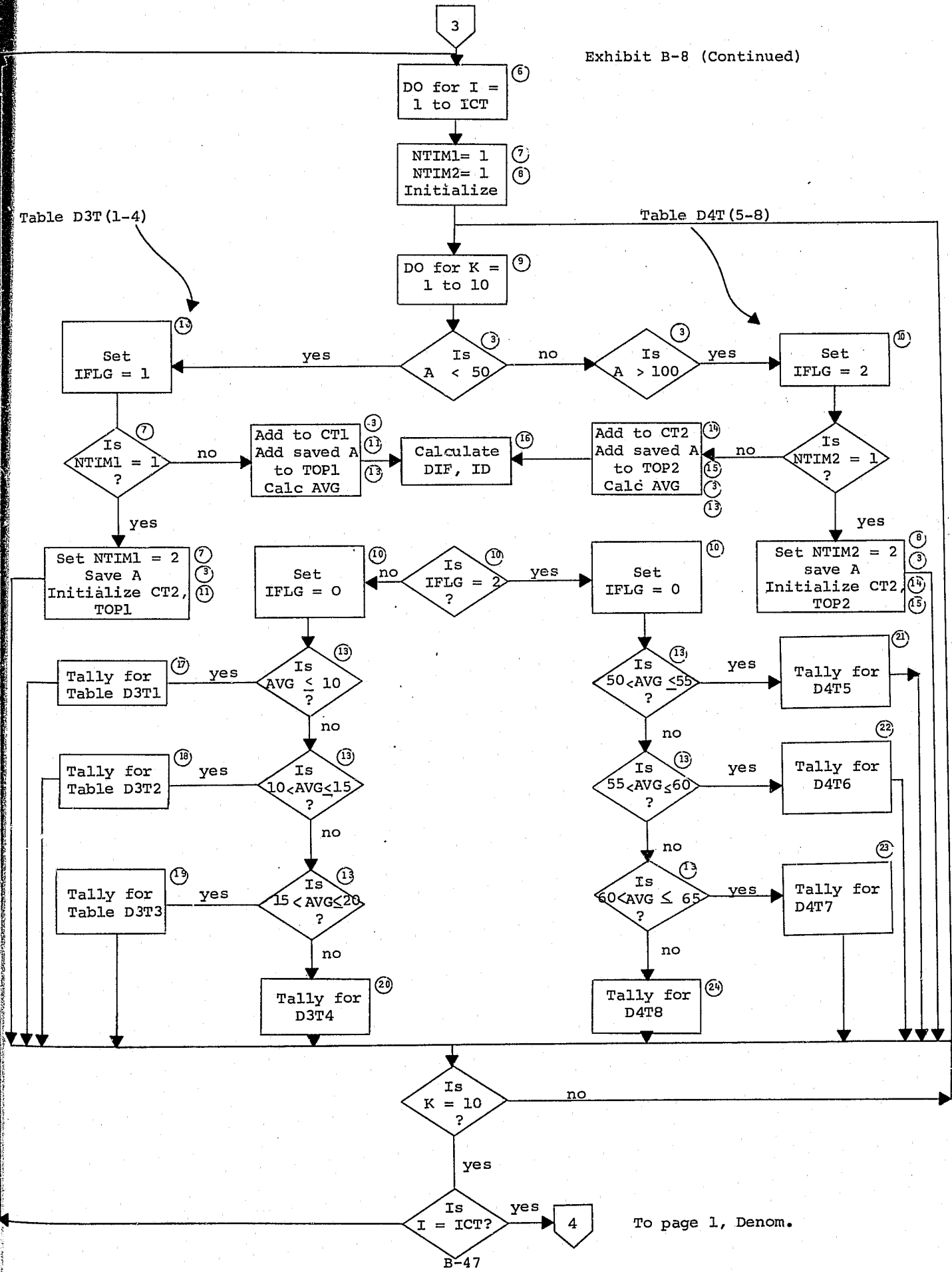

To page 1, Denom.

NOTES ON FLOWCHART

- (1) N number of records on tape
- (2) ITAPE = 0, nothing punched
- (3) IA(I,J) file data, 10 fingers/record, 20 characters/record, Record 1, IA(1,1) - IA(1,10), this is sorted tape of files of 10,000 without counts
- (4) I count for A fingerprint data being read in
- (5) ICNT count of cards
- (6) ICT count of number of records that are alike, over 800 will generate error
- (7) NTIM1 = 1, have not had count under 50 on this fingerprint
= 2 have had count under 50 on this print
- (8) NTIM2 = 1 have not had count 51-99 on this print
= 2 have had count 51-99 on this print
- (9) K number of finger being considered
- (10) IFLG = 1 use Tables D3, 1 to 4
- (11) CT1 count of how many fingers had ridge count 1-49 on the fingerprint card
- (12) TOP1 sum of ridge counts on fingers so far that have been considered with ridge counts 1-49
- (13) AVG average of counts to left of fingers to left of those considered
- (14) CT2 like (11) except for counts 51-99
- (15) TOP2 like (12) except for counts 51-99
- (16) ID row position in Table D3 or D4
- (17) Table 1 see IDENT tables, Table D3, Table 1
- (18) Table 2 see IDENT tables, Table D3, Table 2

NOTES ON FLOWCHART (continued)

- (19) Table 3 see IDENT tables, Table D3, Table 3
- (20) Table 4 see IDENT tables, Table D3, Table 4
- (21) Table 5 see IDENT tables, Table D4, Table 5
- (22) Table 6 see IDENT tables, Table D4, Table 6
- (23) Table 7 see IDENT tables, Table D4, Table 7
- (24) Table 8 see IDENT tables, Table D4, Table 8
- (25) D1 see IDENT tables, Table D1
- (26) D2 see IDENT tables, Table D2

Exhibit B-9. Raw Denominator Tables
(Tables D1 and D2 are found at the end of the listing)

Table D-3, Part 1 1 < Average < 10

| DISTRIBUTION OF COUNTS ABOUT THE AVERAGE OF FINGERS TO THE LEFT OF ONE CONSIDERED | | | | | | | | | | | | |
|---|---|-----|------|------|------|------|------|------|------|------|-------|--|
| | 1 | 2 | 3 | 4 | 5 | 6 | 7 | 8 | 9 | 10 | TOTAL | |
| AVG-ACT | | | | | | | | | | | | |
| B-50 | | | | | | | | | | | | |
| -11 | 0 | 0 | 0 | 0 | 0 | 0 | 0 | 0 | 0 | 0 | 0 | |
| -10-16 | 0 | 0 | 0 | 45 | 13 | 7 | 0 | 1 | 8 | 1 | 75 | |
| -15-11 | 0 | 1 | 24 | 106 | 127 | 81 | 0 | 2 | 57 | 20 | 508 | |
| -10 | 0 | 3 | 14 | 69 | 42 | 37 | 2 | 2 | 72 | 11 | 202 | |
| -9 | 0 | 4 | 21 | 79 | 50 | 62 | 1 | 10 | 47 | 26 | 300 | |
| -8 | 0 | 3 | 25 | 107 | 72 | 95 | 4 | 10 | 60 | 43 | 419 | |
| -7 | 0 | 8 | 38 | 114 | 100 | 72 | 7 | 22 | 82 | 61 | 502 | |
| -6 | 0 | 14 | 67 | 102 | 123 | 114 | 12 | 40 | 104 | 77 | 653 | |
| -5 | 0 | 13 | 79 | 127 | 126 | 134 | 11 | 55 | 154 | 115 | 808 | |
| -4 | 0 | 19 | 96 | 158 | 128 | 157 | 32 | 70 | 165 | 134 | 929 | |
| -3 | 0 | 20 | 96 | 146 | 170 | 162 | 36 | 115 | 187 | 192 | 1134 | |
| -2 | 0 | 30 | 139 | 144 | 177 | 171 | 69 | 158 | 186 | 215 | 1289 | |
| -1 | 0 | 43 | 141 | 128 | 170 | 143 | 104 | 176 | 190 | 234 | 1328 | |
| 0 | 0 | 37 | 129 | 100 | 206 | 126 | 96 | 194 | 184 | 252 | 1335 | |
| 1 | 0 | 42 | 152 | 113 | 170 | 116 | 120 | 206 | 163 | 257 | 1359 | |
| 2 | 0 | 26 | 112 | 97 | 205 | 106 | 105 | 186 | 152 | 253 | 1242 | |
| 3 | 0 | 39 | 116 | 87 | 191 | 74 | 113 | 165 | 138 | 218 | 1141 | |
| 4 | 0 | 37 | 74 | 89 | 131 | 48 | 94 | 160 | 119 | 166 | 918 | |
| 5 | 0 | 23 | 58 | 51 | 101 | 47 | 73 | 112 | 93 | 107 | 663 | |
| 6 | 0 | 19 | 51 | 33 | 64 | 21 | 59 | 90 | 60 | 72 | 469 | |
| 7 | 0 | 13 | 41 | 22 | 26 | 22 | 37 | 36 | 36 | 40 | 273 | |
| 8 | 0 | 13 | 24 | 4 | 8 | 6 | 24 | 34 | 14 | 13 | 140 | |
| 9 | 0 | 4 | 5 | 2 | 2 | 3 | 5 | 4 | 3 | 0 | 28 | |
| 10 | 0 | 0 | 0 | 0 | 0 | 0 | 0 | 0 | 0 | 0 | 0 | |
| +11+15 | 0 | 0 | 0 | 0 | 0 | 0 | 0 | 0 | 0 | 0 | 0 | |
| +16+20 | 0 | 0 | 0 | 0 | 0 | 0 | 0 | 0 | 0 | 0 | 0 | |
| +21 | 0 | 0 | 0 | 0 | 0 | 0 | 0 | 0 | 0 | 0 | 0 | |
| TOTAL | 0 | 411 | 1491 | 1992 | 2407 | 1805 | 1004 | 1848 | 2233 | 2507 | 15765 | |

Table D-3, Part 2 10 < Average < 15

| DISTRIBUTION OF COUNTS ABOUT THE AVERAGE OF FINGERS TO THE LEFT OF ONE CONSIDERED | | | | | | | | | | | | |
|---|---|-----|------|------|------|------|------|------|------|------|-------|--|
| | 1 | 2 | 3 | 4 | 5 | 6 | 7 | 8 | 9 | 10 | TOTAL | |
| AVG-ACT | | | | | | | | | | | | |
| B-51 | | | | | | | | | | | | |
| -21 | 0 | 0 | 0 | 1 | 1 | 0 | 0 | 0 | 2 | 1 | 5 | |
| -20-16 | 0 | 0 | 0 | 2 | 0 | 1 | 1 | 0 | 0 | 0 | 4 | |
| -15-11 | 0 | 0 | 0 | 23 | 10 | 33 | 0 | 0 | 26 | 3 | 95 | |
| -10 | 0 | 0 | 1 | 28 | 10 | 30 | 0 | 0 | 18 | 4 | 91 | |
| -9 | 0 | 1 | 1 | 28 | 10 | 34 | 0 | 2 | 38 | 7 | 121 | |
| -8 | 0 | 0 | 0 | 64 | 40 | 61 | 1 | 5 | 51 | 19 | 241 | |
| -7 | 0 | 2 | 4 | 67 | 49 | 67 | 0 | 10 | 83 | 34 | 356 | |
| -6 | 0 | 1 | 10 | 92 | 60 | 109 | 2 | 18 | 120 | 64 | 506 | |
| -5 | 0 | 3 | 17 | 120 | 140 | 162 | 9 | 48 | 184 | 120 | 818 | |
| -4 | 0 | 9 | 45 | 151 | 188 | 229 | 24 | 95 | 250 | 191 | 1182 | |
| -3 | 0 | 18 | 64 | 199 | 212 | 257 | 38 | 166 | 320 | 278 | 1561 | |
| -2 | 0 | 21 | 104 | 192 | 266 | 273 | 75 | 241 | 360 | 379 | 1911 | |
| -1 | 0 | 25 | 151 | 171 | 317 | 275 | 120 | 381 | 282 | 503 | 2325 | |
| 0 | 0 | 36 | 204 | 191 | 317 | 256 | 166 | 462 | 352 | 516 | 2502 | |
| 1 | 0 | 50 | 214 | 162 | 296 | 224 | 228 | 450 | 265 | 491 | 2300 | |
| 2 | 0 | 53 | 179 | 112 | 297 | 220 | 227 | 453 | 185 | 424 | 2150 | |
| 3 | 0 | 55 | 186 | 88 | 244 | 163 | 247 | 342 | 123 | 354 | 1802 | |
| 4 | 0 | 45 | 160 | 71 | 209 | 113 | 211 | 238 | 92 | 244 | 1383 | |
| 5 | 0 | 49 | 106 | 57 | 203 | 75 | 155 | 193 | 61 | 190 | 1089 | |
| 6 | 0 | 41 | 95 | 62 | 166 | 59 | 123 | 146 | 42 | 110 | 844 | |
| 7 | 0 | 52 | 73 | 52 | 131 | 55 | 96 | 91 | 36 | 107 | 693 | |
| 8 | 0 | 35 | 86 | 53 | 87 | 25 | 90 | 103 | 22 | 66 | 567 | |
| 9 | 0 | 38 | 61 | 34 | 69 | 20 | 70 | 67 | 24 | 40 | 423 | |
| 10 | 0 | 36 | 39 | 29 | 41 | 17 | 48 | 46 | 9 | 15 | 280 | |
| +11+15 | 0 | 78 | 74 | 17 | 25 | 14 | 67 | 55 | 15 | 13 | 358 | |
| +16+20 | 0 | 0 | 0 | 0 | 0 | 0 | 0 | 0 | 0 | 0 | 0 | |
| +21 | 0 | 0 | 0 | 0 | 0 | 0 | 0 | 0 | 0 | 0 | 0 | |
| TOTAL | 0 | 648 | 1874 | 2056 | 3417 | 2808 | 2008 | 3612 | 3089 | 4175 | 23687 | |

DISTRIBUTION OF COUNTS ABOUT THE AVERAGE OF FINGERS TO THE LEFT OF ONE CONSIDERED

| | 1 | 2 | 3 | 4 | 5 | 6 | 7 | 8 | 9 | 10 | TOTAL |
|---------|---|---|---|----|----|----|---|---|----|----|-------|
| AVG-ACT | | | | | | | | | | | |
| -21 | 0 | 1 | 0 | 0 | 0 | 0 | 1 | 0 | 0 | 0 | 2 |
| -20-16 | 0 | 0 | 0 | 0 | 0 | 0 | 0 | 0 | 0 | 0 | 0 |
| -15-11 | 0 | 0 | 0 | 1 | 0 | 4 | 0 | 0 | 7 | 0 | 12 |
| -10 | 0 | 1 | 0 | 1 | 0 | 3 | 0 | 0 | 4 | 0 | 9 |
| -9 | 0 | 0 | 0 | 0 | 0 | 2 | 0 | 0 | 4 | 0 | 12 |
| -8 | 0 | 0 | 0 | 6 | 2 | 8 | 0 | 1 | 8 | 1 | 26 |
| -7 | 0 | 0 | 0 | 5 | 8 | 16 | 1 | 2 | 13 | 4 | 49 |
| -6 | 0 | 0 | 0 | 10 | 7 | 29 | 0 | 4 | 22 | 11 | 83 |
| -5 | 0 | 0 | 0 | 16 | 20 | 44 | 2 | 5 | 40 | 20 | 147 |

| | | | | | | | | | | | |
|--------|---|-----|------|-----|------|------|-----|------|-----|------|-------|
| -4 | C | 1 | 2 | 30 | 25 | 61 | 1 | 7 | 75 | 61 | 243 |
| -3 | C | 0 | 7 | 32 | 40 | 67 | 2 | 26 | 64 | 52 | 341 |
| -2 | C | 0 | 18 | 72 | 81 | 167 | 11 | 57 | 96 | 112 | 601 |
| -1 | C | 1 | 21 | 85 | 121 | 172 | 15 | 79 | 112 | 140 | 713 |
| 0 | C | 18 | 67 | 87 | 133 | 177 | 43 | 162 | 115 | 234 | 979 |
| 1 | C | 27 | 71 | 70 | 181 | 172 | 56 | 184 | 110 | 279 | 1570 |
| 2 | C | 41 | 97 | 78 | 170 | 167 | 80 | 183 | 84 | 233 | 1363 |
| 3 | C | 58 | 154 | 40 | 171 | 27 | 94 | 203 | 56 | 190 | 1062 |
| 4 | C | 88 | 162 | 52 | 134 | 61 | 107 | 172 | 29 | 161 | 946 |
| 5 | C | 89 | 154 | 28 | 104 | 44 | 90 | 98 | 15 | 109 | 736 |
| 6 | C | 65 | 135 | 39 | 94 | 48 | 51 | 63 | 8 | 66 | 567 |
| 7 | C | 71 | 95 | 16 | 73 | 20 | 67 | 41 | 2 | 32 | 417 |
| 8 | C | 50 | 89 | 14 | 54 | 15 | 40 | 33 | 10 | 11 | 316 |
| 9 | C | 42 | 83 | 14 | 46 | 12 | 29 | 18 | 1 | 3 | 248 |
| 10 | C | 43 | 55 | 9 | 35 | 12 | 22 | 14 | 2 | 5 | 197 |
| +11+15 | C | 115 | 212 | 26 | 78 | 9 | 52 | 25 | 6 | 13 | 629 |
| +16+20 | C | 52 | 49 | 8 | 3 | 2 | 12 | 2 | 1 | 0 | 129 |
| +21 | C | 0 | 0 | 0 | 0 | 0 | 0 | 0 | 0 | 0 | 0 |
| TOTAL | C | 631 | 1486 | 750 | 1596 | 1167 | 792 | 1399 | 884 | 1723 | 10637 |

Table D-3, Part 4 20 < Average

DISTRIBUTION OF COUNTS ABOUT THE AVERAGE OF FINGERS TO THE LEFT OF ONE CONSIDERED

| | 1 | 2 | 3 | 4 | 5 | 6 | 7 | 8 | 9 | 10 | TOTAL |
|----------|---|---|---|-----|-----|----|-----|-----|----|----|-------|
| AVG-ACT | | | | | | | | | | | |
| B-52 -21 | C | C | 1 | 0 | 0 | 0 | 0 | 0 | 0 | 0 | 1 |
| -20-16 | C | C | C | 0 | 0 | 0 | 1 | 0 | 0 | 0 | 1 |
| -15-11 | C | C | C | 0 | 0 | C | 0 | 0 | C | C | 0 |
| -10 | C | C | C | 0 | 0 | 1 | 0 | 0 | 0 | 0 | 1 |
| -9 | C | C | C | 0 | 0 | 0 | 0 | 0 | 1 | 0 | 1 |
| -8 | C | C | C | 1 | 0 | C | 0 | 0 | 1 | C | 2 |
| -7 | C | C | C | 0 | 0 | 0 | 0 | 0 | 2 | 0 | 2 |
| -6 | C | C | C | 2 | 0 | 0 | 0 | 0 | 1 | 0 | 3 |
| -5 | C | C | C | 0 | 0 | 1 | 0 | 0 | 1 | 2 | 4 |
| -4 | C | C | C | 0 | 0 | 4 | 0 | 0 | 2 | 0 | 6 |
| -3 | C | C | C | 0 | 1 | 2 | 1 | 1 | 0 | 3 | 8 |
| -2 | C | C | C | 3 | 3 | 4 | 0 | 1 | 6 | 1 | 20 |
| -1 | C | C | C | 4 | 0 | 13 | 0 | 2 | 3 | 9 | 33 |
| 0 | C | C | C | 2 | 10 | 6 | 1 | 6 | 8 | 10 | 47 |
| 1 | C | C | C | 4 | 14 | 9 | C | 6 | 6 | 15 | 60 |
| 2 | C | C | C | 5 | 14 | 14 | 1 | 7 | 2 | 10 | 64 |
| 3 | C | C | C | 5 | 11 | 2 | 13 | 2 | 2 | 23 | 84 |
| 4 | C | C | C | 15 | 16 | 21 | 12 | 2 | 4 | 24 | 115 |
| 5 | C | C | C | 22 | 23 | 21 | 5 | 9 | 14 | 7 | 114 |
| 6 | C | C | C | 23 | 40 | 7 | 12 | 7 | 14 | 1 | 129 |
| 7 | C | C | C | 39 | 42 | 6 | 19 | 6 | 4 | C | 126 |
| 8 | C | C | C | 36 | 50 | 5 | 19 | 7 | 3 | 1 | 132 |
| 9 | C | C | C | 34 | 50 | 3 | 15 | 7 | 6 | 0 | 123 |
| 10 | C | C | C | 59 | 36 | 2 | 4 | 3 | 4 | 0 | 88 |
| +11+15 | C | C | C | 85 | 127 | 9 | 29 | 3 | 6 | 0 | 265 |
| +16+20 | C | C | C | 79 | 73 | 5 | 7 | 1 | 3 | 0 | 170 |
| +21 | C | C | C | 23 | 15 | 0 | 2 | 0 | 2 | 0 | 43 |
| TOTAL | C | C | C | 418 | 499 | 68 | 215 | 117 | 94 | 43 | 1642 |

Table D-4, Part 1 1 ≤ Average ≤ 5

DISTRIBUTION OF COUNTS ABOUT THE AVERAGE OF FINGERS TO THE LEFT OF ONE CONSIDERED

| | 1 | 2 | 3 | 4 | 5 | 6 | 7 | 8 | 9 | 10 | TOTAL | | |
|----------|---|---|---|---|----|---|----|----|-----|----|-------|---|-----|
| AVG-ACT | | | | | | | | | | | | | |
| B-53 -21 | C | C | C | C | 0 | 0 | 0 | 0 | 0 | 0 | 0 | | |
| -20-16 | C | C | C | 1 | 0 | 0 | C | 2 | 0 | 1 | 4 | | |
| -15-11 | C | C | C | 0 | 0 | 0 | 0 | 7 | 1 | 1 | 11 | | |
| -10 | C | C | C | 0 | 0 | 0 | 3 | 0 | 0 | 0 | 3 | | |
| -9 | C | C | C | 0 | 0 | C | 0 | 3 | 0 | 0 | 3 | | |
| -8 | C | C | C | 0 | 0 | 0 | 2 | 0 | 0 | 0 | 2 | | |
| -7 | C | C | C | 1 | 0 | C | 0 | 2 | 0 | 2 | 6 | | |
| -6 | C | C | C | 0 | 1 | 1 | 0 | 4 | 0 | 0 | 6 | | |
| -5 | C | C | C | 1 | 2 | 0 | 0 | 8 | 1 | 0 | 12 | | |
| -4 | C | C | C | 2 | 0 | 0 | 0 | 17 | 0 | 1 | 21 | | |
| -3 | C | C | C | 0 | 0 | 0 | C | 17 | 1 | 0 | 18 | | |
| -2 | C | C | C | 1 | 0 | C | 6 | 4 | 1 | C | 42 | | |
| -1 | C | C | C | 3 | 0 | 0 | 39 | 5 | 1 | 0 | 48 | | |
| 0 | C | C | C | 1 | 0 | 0 | 58 | 9 | 1 | C | 70 | | |
| 1 | C | C | C | 2 | 0 | 0 | 37 | 13 | 1 | C | 53 | | |
| 2 | C | C | C | 0 | 0 | 0 | 12 | 7 | 0 | 0 | 21 | | |
| 3 | C | C | C | 0 | 0 | C | 3 | 5 | 0 | 0 | 8 | | |
| 4 | C | C | C | 0 | 0 | 0 | 1 | 0 | 0 | C | 3 | | |
| 5 | C | C | C | 0 | 0 | 0 | 0 | 0 | 0 | 0 | 0 | | |
| 6 | C | C | C | 0 | 0 | 0 | 0 | 0 | 0 | C | 0 | | |
| 7 | C | C | C | 0 | 0 | 0 | 0 | 0 | 0 | C | 0 | | |
| 8 | C | C | C | 0 | 0 | 0 | 0 | 0 | 0 | 0 | 0 | | |
| 9 | C | C | C | 0 | 0 | C | 0 | 0 | 0 | 0 | 0 | | |
| 10 | C | C | C | 0 | 0 | 0 | 0 | 0 | 0 | C | 0 | | |
| +11+15 | C | C | C | 0 | 0 | 0 | 0 | 0 | 0 | 0 | 0 | | |
| +16+20 | C | C | C | 0 | 0 | 0 | 0 | 0 | 0 | 0 | 0 | | |
| +21 | C | C | C | 0 | 0 | 0 | 0 | 0 | 0 | 0 | 0 | | |
| TOTAL | C | C | C | 1 | 13 | 8 | 1 | 1 | 251 | 46 | 8 | 2 | 351 |

Table D-4, Part 2 5 < Average ≤ 10

DISTRIBUTION OF COUNTS ABOUT THE AVERAGE OF FINGERS TO THE LEFT OF ONE CONSIDERED

| | 1 | 2 | 3 | 4 | 5 | 6 | 7 | 8 | 9 | 10 | TOTAL |
|---------|---|---|---|---|---|---|----|---|---|----|-------|
| AVG-ACT | | | | | | | | | | | |
| -21 | C | C | C | 0 | 0 | 0 | 0 | C | 0 | 0 | 0 |
| -20-16 | C | C | C | 0 | 0 | 0 | 0 | 0 | C | 0 | 0 |
| -15-11 | C | C | C | 0 | 0 | C | 2 | C | C | C | 2 |
| -10 | C | C | C | 0 | 0 | 0 | 0 | 0 | 0 | 0 | 0 |
| -9 | C | C | C | 0 | C | 1 | 0 | C | 0 | C | 1 |
| -8 | C | C | C | 0 | 0 | 0 | 4 | 0 | 0 | 0 | 4 |
| -7 | C | C | C | 0 | 0 | 0 | 4 | 0 | 0 | 0 | 4 |
| -6 | C | C | C | 1 | 0 | 0 | 0 | 0 | 1 | 0 | 2 |
| -5 | C | C | C | 0 | C | 0 | 2 | 1 | 0 | C | 3 |
| -4 | C | C | C | 3 | 0 | 0 | 4 | 1 | 0 | 0 | 8 |
| -3 | C | C | C | 0 | 0 | 0 | 11 | 1 | 1 | C | 13 |

| | | | | | | | | | | | |
|--------|---|---|---|---|---|---|-----|----|---|---|-----|
| -2 | 0 | 1 | 0 | 0 | 0 | 0 | 11 | 0 | 1 | 0 | 13 |
| -1 | 0 | 0 | 1 | 0 | 0 | 0 | 17 | 1 | 2 | 0 | 21 |
| 0 | 0 | 0 | 2 | 0 | 0 | 0 | 13 | 1 | 0 | 0 | 17 |
| 1 | 0 | 0 | 1 | 1 | 0 | 0 | 5 | 2 | 0 | 0 | 8 |
| 2 | 0 | 0 | 2 | 1 | 1 | 0 | 15 | 0 | 0 | 0 | 19 |
| 3 | 0 | 0 | 0 | 0 | 0 | 0 | 8 | 4 | 0 | 0 | 12 |
| 4 | 0 | 0 | 1 | 2 | 0 | 0 | 9 | 8 | 0 | 0 | 20 |
| 5 | 0 | 0 | 1 | 0 | 0 | 0 | 14 | 7 | 0 | 0 | 22 |
| 6 | 0 | 0 | 0 | 0 | 1 | 0 | 7 | 4 | 1 | 0 | 13 |
| 7 | 0 | 0 | 0 | 0 | 0 | 0 | 7 | 5 | 0 | 0 | 12 |
| 8 | 0 | 0 | 0 | 0 | 0 | 0 | 2 | 0 | 0 | 0 | 2 |
| 9 | 0 | 0 | 1 | 0 | 0 | 0 | 0 | 0 | 0 | 0 | 1 |
| 10 | 0 | 0 | 0 | 0 | 0 | 0 | 0 | 0 | 0 | 0 | 0 |
| +11+15 | 0 | 0 | 0 | 0 | 0 | 0 | 0 | 0 | 0 | 0 | 0 |
| +16+20 | 0 | 0 | 0 | 0 | 0 | 0 | 0 | 0 | 0 | 0 | 0 |
| +21 | 0 | 0 | 0 | 0 | 0 | 0 | 0 | 0 | 0 | 0 | 0 |
| TOTAL | 0 | 1 | 8 | 8 | 2 | 2 | 135 | 35 | 6 | 0 | 197 |

Table D-4, Part 3 10 < Average ≤ 15

DISTRIBUTION OF COUNTS ABOUT THE AVERAGE OF FINGERS TO THE LEFT OF ONE CONSIDERED

| | | 1 | 2 | 3 | 4 | 5 | 6 | 7 | 8 | 9 | 10 | TOTAL |
|---------|--------|---|---|----|---|---|---|-----|----|---|----|-------|
| AVG-ACT | | | | | | | | | | | | |
| B-54 | -21 | 0 | 0 | 0 | 0 | 0 | 0 | 0 | 0 | 0 | 0 | 0 |
| | -20-16 | 0 | 0 | 0 | 0 | 0 | 0 | 0 | 0 | 0 | 0 | 0 |
| | -15-11 | 0 | 0 | 0 | 0 | 0 | 0 | 0 | 0 | 0 | 0 | 0 |
| | -10 | 0 | 0 | 0 | 0 | 0 | 0 | 0 | 0 | 0 | 0 | 0 |
| | -9 | 0 | 0 | 0 | 0 | 0 | 0 | 1 | 0 | 0 | 0 | 1 |
| | -8 | 0 | 0 | 0 | 0 | 0 | 0 | 2 | 1 | 0 | 0 | 3 |
| | -7 | 0 | 0 | 0 | 0 | 0 | 0 | 2 | 1 | 0 | 0 | 3 |
| | -6 | 0 | 0 | 0 | 1 | 0 | 0 | 7 | 0 | 0 | 0 | 8 |
| | -5 | 0 | 0 | 0 | 0 | 0 | 0 | 4 | 0 | 0 | 0 | 4 |
| | -4 | 0 | 0 | 0 | 0 | 0 | 0 | 3 | 0 | 0 | 0 | 3 |
| | -3 | 0 | 0 | 0 | 0 | 0 | 1 | 8 | 0 | 0 | 0 | 9 |
| | -2 | 0 | 0 | 1 | 0 | 0 | 1 | 9 | 1 | 0 | 0 | 12 |
| | -1 | 0 | 0 | 1 | 1 | 0 | 1 | 16 | 0 | 0 | 0 | 19 |
| | 0 | 0 | 0 | 1 | 1 | 0 | 0 | 19 | 0 | 0 | 0 | 21 |
| | 1 | 0 | 0 | 1 | 0 | 0 | 1 | 12 | 0 | 1 | 0 | 15 |
| | 2 | 0 | 0 | 1 | 0 | 0 | 0 | 8 | 1 | 0 | 0 | 10 |
| | 3 | 0 | 0 | 3 | 1 | 0 | 1 | 5 | 1 | 0 | 1 | 12 |
| | 4 | 0 | 1 | 6 | 0 | 1 | 0 | 5 | 1 | 0 | 0 | 14 |
| | 5 | 0 | 0 | 0 | 0 | 0 | 0 | 9 | 0 | 0 | 0 | 9 |
| | 6 | 0 | 0 | 1 | 0 | 0 | 0 | 6 | 1 | 0 | 0 | 8 |
| | 7 | 0 | 0 | 0 | 0 | 0 | 0 | 6 | 0 | 0 | 0 | 6 |
| | 8 | 0 | 0 | 2 | 0 | 1 | 0 | 11 | 0 | 0 | 0 | 14 |
| | 9 | 0 | 0 | 2 | 0 | 0 | 0 | 6 | 2 | 0 | 0 | 10 |
| | 10 | 0 | 1 | 2 | 0 | 0 | 0 | 8 | 2 | 0 | 1 | 14 |
| | +11+15 | 0 | 1 | 2 | 0 | 0 | 0 | 11 | 2 | 0 | 0 | 16 |
| | +16+20 | 0 | 0 | 0 | 0 | 0 | 0 | 0 | 0 | 0 | 0 | 0 |
| | +21 | 0 | 0 | 0 | 0 | 0 | 0 | 0 | 0 | 0 | 0 | 0 |
| | TOTAL | 0 | 3 | 23 | 4 | 2 | 5 | 158 | 13 | 1 | 2 | 211 |

DISTRIBUTION OF COUNTS ABOUT THE AVERAGE OF FINGERS TO THE LEFT OF ONE CONSIDERED

| | | 1 | 2 | 3 | 4 | 5 | 6 | 7 | 8 | 9 | 10 | TOTAL |
|---------|--------|---|---|----|---|---|---|-----|----|---|----|-------|
| AVG-ACT | | | | | | | | | | | | |
| B-55 | -21 | 0 | 0 | 0 | 0 | 0 | 0 | 0 | 0 | 0 | 0 | 0 |
| | -20-16 | 0 | 0 | 0 | 0 | 0 | 0 | 0 | 0 | 0 | 0 | 0 |
| | -15-11 | 0 | 0 | 1 | 0 | 0 | 0 | 0 | 0 | 0 | 0 | 1 |
| | -10 | 0 | 0 | 0 | 0 | 0 | 0 | 0 | 0 | 0 | 0 | 0 |
| | -9 | 0 | 0 | 0 | 0 | 0 | 0 | 0 | 0 | 0 | 0 | 0 |
| | -8 | 0 | 0 | 0 | 0 | 0 | 0 | 0 | 0 | 0 | 0 | 0 |
| | -7 | 0 | 0 | 0 | 0 | 0 | 0 | 0 | 0 | 0 | 0 | 0 |
| | -6 | 0 | 0 | 1 | 0 | 0 | 0 | 0 | 0 | 0 | 0 | 1 |
| | -5 | 0 | 0 | 1 | 0 | 0 | 0 | 2 | 0 | 0 | 0 | 3 |
| | -4 | 0 | 0 | 0 | 0 | 0 | 0 | 7 | 0 | 0 | 0 | 7 |
| | -3 | 0 | 0 | 0 | 0 | 0 | 0 | 5 | 0 | 0 | 0 | 5 |
| | -2 | 0 | 0 | 1 | 0 | 0 | 0 | 3 | 2 | 0 | 0 | 6 |
| | -1 | 0 | 0 | 2 | 0 | 0 | 0 | 14 | 1 | 0 | 0 | 17 |
| | 0 | 0 | 0 | 0 | 0 | 0 | 0 | 21 | 0 | 0 | 0 | 21 |
| | 1 | 0 | 0 | 2 | 0 | 0 | 0 | 16 | 0 | 0 | 0 | 18 |
| | 2 | 0 | 0 | 1 | 0 | 0 | 0 | 8 | 0 | 0 | 0 | 9 |
| | 3 | 0 | 1 | 2 | 0 | 0 | 0 | 5 | 1 | 0 | 0 | 9 |
| | 4 | 0 | 0 | 0 | 1 | 0 | 1 | 6 | 1 | 0 | 1 | 10 |
| | 5 | 0 | 2 | 3 | 0 | 0 | 0 | 6 | 1 | 0 | 0 | 12 |
| | 6 | 0 | 0 | 5 | 0 | 1 | 0 | 7 | 0 | 0 | 0 | 11 |
| | 7 | 0 | 0 | 1 | 0 | 0 | 0 | 2 | 0 | 0 | 0 | 3 |
| | 8 | 0 | 0 | 2 | 0 | 0 | 0 | 2 | 0 | 0 | 0 | 4 |
| | 9 | 0 | 1 | 1 | 0 | 0 | 0 | 1 | 0 | 0 | 0 | 3 |
| | 10 | 0 | 0 | 2 | 0 | 0 | 0 | 0 | 0 | 0 | 0 | 2 |
| | +11+15 | 0 | 1 | 3 | 0 | 0 | 0 | 15 | 7 | 0 | 1 | 27 |
| | +16+20 | 0 | 2 | 0 | 0 | 0 | 0 | 1 | 2 | 0 | 0 | 5 |
| | +21 | 0 | 0 | 0 | 0 | 0 | 0 | 0 | 2 | 0 | 0 | 2 |
| | TOTAL | 0 | 7 | 26 | 1 | 1 | 1 | 121 | 17 | 0 | 2 | 176 |

DISTRIBUTION OF RIDGE COUNTS BY FINGER

Table D-1

| COUNT | 1 | 2 | 3 | 4 | 5 | 6 | 7 | 8 | 9 | 10 | TOTAL |
|-------|-----|-----|-----|-----|-----|-----|-----|-----|-----|-----|-------|
| 1 | 14 | 96 | 72 | 20 | 19 | 17 | 72 | 52 | 47 | 27 | 452 |
| 2 | 44 | 194 | 272 | 115 | 133 | 58 | 161 | 200 | 122 | 126 | 1433 |
| 3 | 48 | 216 | 255 | 154 | 200 | 71 | 155 | 249 | 167 | 230 | 1785 |
| 4 | 60 | 184 | 288 | 195 | 296 | 103 | 177 | 243 | 188 | 258 | 1992 |
| 5 | 72 | 181 | 282 | 189 | 337 | 113 | 176 | 215 | 165 | 254 | 1984 |
| 6 | 92 | 178 | 296 | 178 | 380 | 150 | 187 | 267 | 161 | 366 | 2303 |
| 7 | 114 | 195 | 346 | 148 | 383 | 150 | 240 | 284 | 174 | 344 | 2428 |
| 8 | 139 | 199 | 423 | 180 | 370 | 228 | 267 | 388 | 199 | 365 | 2754 |
| 9 | 142 | 204 | 439 | 208 | 442 | 265 | 367 | 366 | 237 | 419 | 3119 |
| 10 | 203 | 225 | 501 | 234 | 431 | 328 | 349 | 506 | 277 | 532 | 3586 |
| 11 | 242 | 282 | 683 | 268 | 508 | 381 | 370 | 640 | 397 | 667 | 4438 |
| 12 | 274 | 286 | 659 | 296 | 614 | 443 | 364 | 716 | 445 | 764 | 4863 |
| 13 | 271 | 275 | 679 | 357 | 639 | 466 | 276 | 638 | 524 | 779 | 4904 |
| 14 | 277 | 241 | 591 | 427 | 662 | 473 | 258 | 612 | 556 | 781 | 4870 |
| 15 | 322 | 193 | 481 | 358 | 664 | 452 | 170 | 523 | 526 | 675 | 4404 |
| 16 | 402 | 165 | 415 | 400 | 623 | 480 | 131 | 407 | 513 | 679 | 4215 |
| 17 | 415 | 112 | 227 | 356 | 495 | 426 | 83 | 279 | 403 | 450 | 3246 |
| 18 | 445 | 59 | 171 | 311 | 421 | 376 | 46 | 195 | 344 | 397 | 2765 |

| | | | | | | | | | | | |
|-------|------|------|------|------|------|------|------|------|------|------|-------|
| 1 | 1 | 42 | 12 | 275 | 292 | 318 | 25 | 81 | 257 | 219 | 1854 |
| 2 | 364 | 21 | 41 | 161 | 161 | 203 | 7 | 47 | 173 | 14 | 1310 |
| 3 | 176 | 15 | 23 | 151 | 110 | 207 | 7 | 31 | 172 | 60 | 1066 |
| 4 | 140 | 7 | 14 | 51 | 51 | 114 | 1 | 10 | 7 | 42 | 662 |
| 5 | 164 | 3 | 5 | 41 | 34 | 75 | 2 | 5 | 47 | 20 | 366 |
| 6 | 128 | 0 | 2 | 35 | 15 | 43 | 2 | 3 | 24 | 10 | 267 |
| 7 | 64 | 1 | 0 | 17 | 5 | 25 | 2 | 3 | 20 | 2 | 139 |
| 8 | 48 | 1 | 0 | 5 | 5 | 16 | 0 | 0 | 23 | 3 | 161 |
| 9 | 28 | 0 | 0 | 3 | 0 | 6 | 0 | 0 | 4 | 1 | 50 |
| 10 | 17 | 0 | 0 | 4 | 0 | 4 | 1 | 0 | 4 | 0 | 30 |
| 11 | 13 | 0 | 0 | 2 | 0 | 0 | 0 | 0 | 4 | 0 | 19 |
| 12 | 8 | 1 | 0 | 1 | 1 | 1 | 0 | 0 | 1 | 1 | 14 |
| 13 | 4 | 0 | 0 | 0 | 0 | 0 | 0 | 0 | 2 | 0 | 6 |
| 14 | 1 | 0 | 0 | 0 | 0 | 1 | 0 | 0 | 1 | 0 | 3 |
| 15 | 1 | 0 | 0 | 0 | 0 | 0 | 0 | 0 | 1 | 0 | 2 |
| 16 | 0 | 0 | 0 | 1 | 0 | 0 | 0 | 0 | 1 | 0 | 2 |
| 17 | 0 | 0 | 0 | 0 | 0 | 0 | 0 | 0 | 0 | 0 | 0 |
| 18 | 0 | 0 | 0 | 0 | 0 | 0 | 0 | 0 | 0 | 0 | 0 |
| 19 | 0 | 0 | 0 | 0 | 0 | 0 | 0 | 0 | 0 | 0 | 0 |
| 20 | 0 | 0 | 0 | 0 | 0 | 0 | 0 | 0 | 0 | 0 | 0 |
| 21 | 0 | 0 | 0 | 0 | 0 | 0 | 0 | 0 | 0 | 0 | 0 |
| 22 | 0 | 0 | 0 | 0 | 0 | 0 | 0 | 0 | 0 | 0 | 0 |
| 23 | 0 | 0 | 0 | 0 | 0 | 0 | 0 | 0 | 0 | 0 | 0 |
| 24 | 0 | 0 | 0 | 0 | 0 | 0 | 0 | 0 | 0 | 0 | 0 |
| 25 | 0 | 0 | 0 | 0 | 0 | 0 | 0 | 0 | 0 | 0 | 0 |
| 26 | 0 | 0 | 0 | 0 | 0 | 0 | 0 | 0 | 0 | 0 | 0 |
| 27 | 0 | 0 | 0 | 0 | 0 | 0 | 0 | 0 | 0 | 0 | 0 |
| 28 | 0 | 0 | 0 | 0 | 0 | 0 | 0 | 0 | 0 | 0 | 0 |
| 29 | 0 | 0 | 0 | 0 | 0 | 0 | 0 | 0 | 0 | 0 | 0 |
| 30 | 0 | 0 | 0 | 0 | 0 | 0 | 0 | 0 | 0 | 0 | 0 |
| 31 | 0 | 0 | 0 | 0 | 0 | 0 | 0 | 0 | 0 | 0 | 0 |
| 32 | 0 | 0 | 0 | 0 | 0 | 0 | 0 | 0 | 0 | 0 | 0 |
| 33 | 0 | 0 | 0 | 0 | 0 | 0 | 0 | 0 | 0 | 0 | 0 |
| 34 | 0 | 0 | 0 | 0 | 0 | 0 | 0 | 0 | 0 | 0 | 0 |
| 35 | 0 | 0 | 0 | 0 | 0 | 0 | 0 | 0 | 0 | 0 | 0 |
| 36 | 0 | 0 | 0 | 0 | 0 | 0 | 0 | 0 | 0 | 0 | 0 |
| 37 | 0 | 0 | 0 | 0 | 0 | 0 | 0 | 0 | 0 | 0 | 0 |
| 38 | 0 | 0 | 0 | 0 | 0 | 0 | 0 | 0 | 0 | 0 | 0 |
| 39 | 0 | 0 | 0 | 0 | 0 | 0 | 0 | 0 | 0 | 0 | 0 |
| 40 | 0 | 0 | 0 | 0 | 0 | 0 | 0 | 0 | 0 | 0 | 0 |
| 41 | 0 | 0 | 0 | 0 | 0 | 0 | 0 | 0 | 0 | 0 | 0 |
| 42 | 0 | 0 | 0 | 0 | 0 | 0 | 0 | 0 | 0 | 0 | 0 |
| 43 | 0 | 0 | 0 | 0 | 0 | 0 | 0 | 0 | 0 | 0 | 0 |
| 44 | 0 | 0 | 0 | 0 | 0 | 0 | 0 | 0 | 0 | 0 | 0 |
| 45 | 0 | 0 | 0 | 0 | 0 | 0 | 0 | 0 | 0 | 0 | 0 |
| 46 | 0 | 0 | 0 | 0 | 0 | 0 | 0 | 0 | 0 | 0 | 0 |
| 47 | 0 | 1 | 1 | 0 | 1 | 0 | 0 | 0 | 0 | 0 | 3 |
| 48 | 0 | 0 | 0 | 0 | 0 | 0 | 1 | 0 | 1 | 0 | 2 |
| 49 | 0 | 0 | 0 | 0 | 0 | 0 | 0 | 0 | 0 | 1 | 1 |
| TOTAL | 5272 | 3580 | 7294 | 5171 | 8322 | 6033 | 3898 | 7028 | 6261 | 8649 | 61508 |

P-56

TABLE D2
DISTRIBUTION OF PIDGE COUNTS BY FINGER

Table D-2

| COUNT | 1 | 2 | 3 | 4 | 5 | 6 | 7 | 8 | 9 | 10 | TOTAL |
|-------|----|------|-----|-----|----|----|------|-----|----|----|-------|
| 51 | 1 | 47 | 12 | 2 | 0 | 0 | 66 | 21 | 3 | 2 | 154 |
| 52 | 1 | 141 | 13 | 1 | 1 | 0 | 108 | 62 | 5 | 0 | 412 |
| 53 | 1 | 146 | 12 | 8 | 1 | 1 | 214 | 30 | 4 | 1 | 418 |
| 54 | 2 | 127 | 10 | 2 | 1 | 2 | 193 | 19 | 2 | 1 | 365 |
| 55 | 0 | 56 | 6 | 6 | 2 | 1 | 118 | 11 | 4 | 1 | 245 |
| 56 | 0 | 10 | 1 | 8 | 5 | 2 | 111 | 7 | 5 | 0 | 226 |
| 57 | 2 | 50 | 6 | 5 | 2 | 1 | 82 | 7 | 3 | 0 | 158 |
| 58 | 3 | 50 | 5 | 12 | 3 | 10 | 60 | 4 | 1 | 3 | 151 |
| 59 | 1 | 65 | 3 | 13 | 1 | 2 | 40 | 3 | 6 | 0 | 143 |
| 60 | 3 | 54 | 7 | 10 | 5 | 3 | 48 | 1 | 0 | 1 | 132 |
| 61 | 5 | 72 | 14 | 9 | 4 | 5 | 41 | 2 | 6 | 0 | 158 |
| 62 | 3 | 84 | 4 | 4 | 6 | 1 | 44 | 4 | 4 | 0 | 154 |
| 63 | 3 | 104 | 9 | 4 | 2 | 4 | 56 | 5 | 2 | 2 | 191 |
| 64 | 2 | 69 | 8 | 7 | 2 | 3 | 52 | 1 | 2 | 2 | 178 |
| 65 | 4 | 96 | 5 | 7 | 0 | 6 | 56 | 2 | 1 | 0 | 177 |
| 66 | 1 | 68 | 5 | 4 | 0 | 1 | 55 | 2 | 0 | 0 | 166 |
| 67 | 2 | 88 | 2 | 3 | 0 | 2 | 72 | 2 | 0 | 0 | 171 |
| 68 | 3 | 66 | 3 | 0 | 0 | 2 | 55 | 2 | 1 | 0 | 132 |
| 69 | 0 | 48 | 4 | 0 | 0 | 4 | 35 | 3 | 0 | 0 | 94 |
| 70 | 0 | 42 | 1 | 0 | 0 | 1 | 28 | 0 | 0 | 1 | 78 |
| 71 | 0 | 33 | 0 | 0 | 0 | 0 | 25 | 0 | 0 | 0 | 62 |
| 72 | 0 | 11 | 1 | 0 | 0 | 0 | 3 | 0 | 0 | 0 | 15 |
| 73 | 0 | 6 | 0 | 0 | 0 | 0 | 0 | 0 | 0 | 0 | 7 |
| 74 | 0 | 0 | 0 | 0 | 0 | 0 | 0 | 0 | 0 | 0 | 0 |
| 75 | 0 | 0 | 1 | 0 | 0 | 0 | 2 | 0 | 0 | 0 | 3 |
| 76 | 0 | 0 | 0 | 0 | 0 | 0 | 1 | 0 | 0 | 0 | 1 |
| 77 | 0 | 0 | 0 | 0 | 0 | 0 | 0 | 0 | 0 | 0 | 0 |
| 78 | 0 | 0 | 0 | 0 | 0 | 0 | 0 | 0 | 0 | 0 | 0 |
| 79 | 0 | 0 | 0 | 0 | 0 | 0 | 0 | 0 | 0 | 0 | 0 |
| 80 | 0 | 3 | 0 | 0 | 0 | 0 | 1 | 0 | 0 | 0 | 4 |
| 81 | 0 | 0 | 0 | 0 | 0 | 0 | 0 | 0 | 0 | 0 | 0 |
| 82 | 0 | 0 | 0 | 0 | 0 | 0 | 0 | 0 | 0 | 0 | 0 |
| 83 | 0 | 0 | 0 | 0 | 0 | 0 | 0 | 0 | 0 | 0 | 0 |
| 84 | 0 | 0 | 0 | 0 | 0 | 0 | 0 | 0 | 0 | 0 | 0 |
| 85 | 0 | 0 | 0 | 0 | 0 | 0 | 0 | 0 | 0 | 0 | 0 |
| 86 | 0 | 0 | 0 | 0 | 0 | 0 | 0 | 0 | 0 | 0 | 0 |
| 87 | 0 | 0 | 0 | 0 | 0 | 0 | 0 | 0 | 0 | 0 | 0 |
| 88 | 0 | 0 | 0 | 0 | 0 | 0 | 0 | 0 | 0 | 0 | 0 |
| 89 | 0 | 0 | 0 | 0 | 0 | 0 | 0 | 0 | 0 | 0 | 0 |
| 90 | 0 | 0 | 0 | 0 | 0 | 0 | 0 | 0 | 0 | 0 | 0 |
| 91 | 0 | 0 | 0 | 0 | 0 | 0 | 0 | 0 | 0 | 0 | 0 |
| 92 | 0 | 0 | 0 | 0 | 0 | 0 | 0 | 0 | 0 | 0 | 0 |
| 93 | 0 | 0 | 0 | 0 | 0 | 0 | 0 | 0 | 0 | 0 | 0 |
| 94 | 0 | 0 | 0 | 0 | 0 | 0 | 0 | 0 | 0 | 0 | 0 |
| 95 | 0 | 0 | 0 | 0 | 0 | 0 | 0 | 0 | 0 | 0 | 0 |
| 96 | 0 | 0 | 0 | 0 | 0 | 0 | 0 | 0 | 0 | 0 | 0 |
| 97 | 0 | 0 | 0 | 0 | 0 | 0 | 0 | 0 | 0 | 0 | 0 |
| 98 | 0 | 0 | 0 | 0 | 0 | 0 | 0 | 0 | 0 | 0 | 0 |
| 99 | 0 | 0 | 0 | 0 | 0 | 0 | 0 | 0 | 0 | 0 | 0 |
| TOTAL | 45 | 1746 | 145 | 112 | 35 | 55 | 1672 | 193 | 40 | 16 | 4068 |

B-57

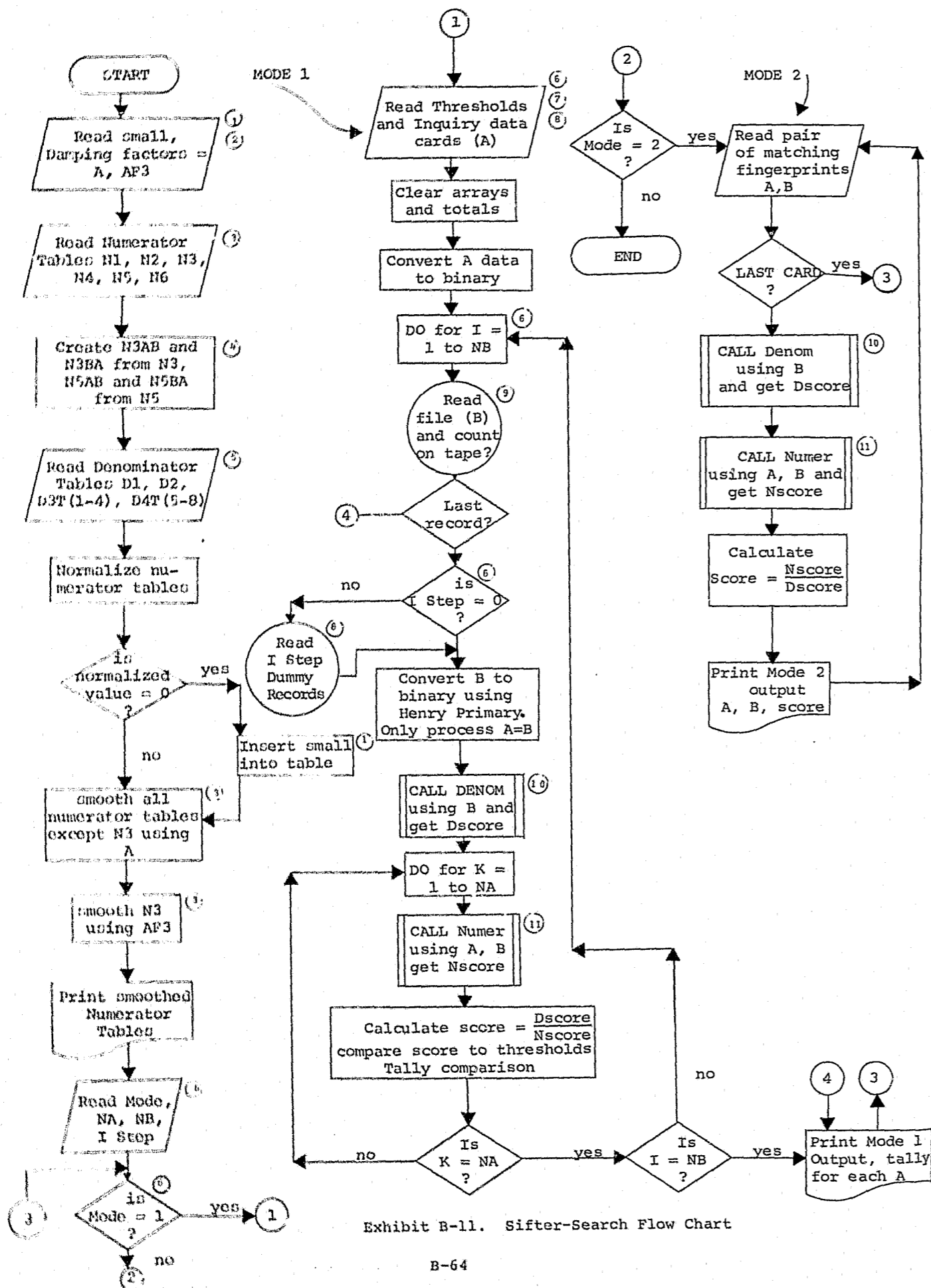
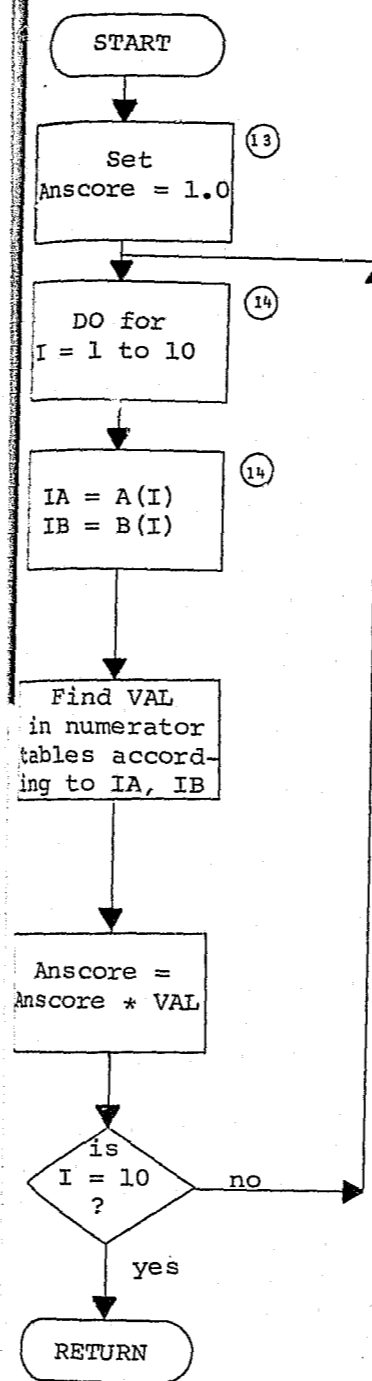

Exhibit B-11. Sifter-Search Flow Chart



NUMERATOR SUBROUTINE

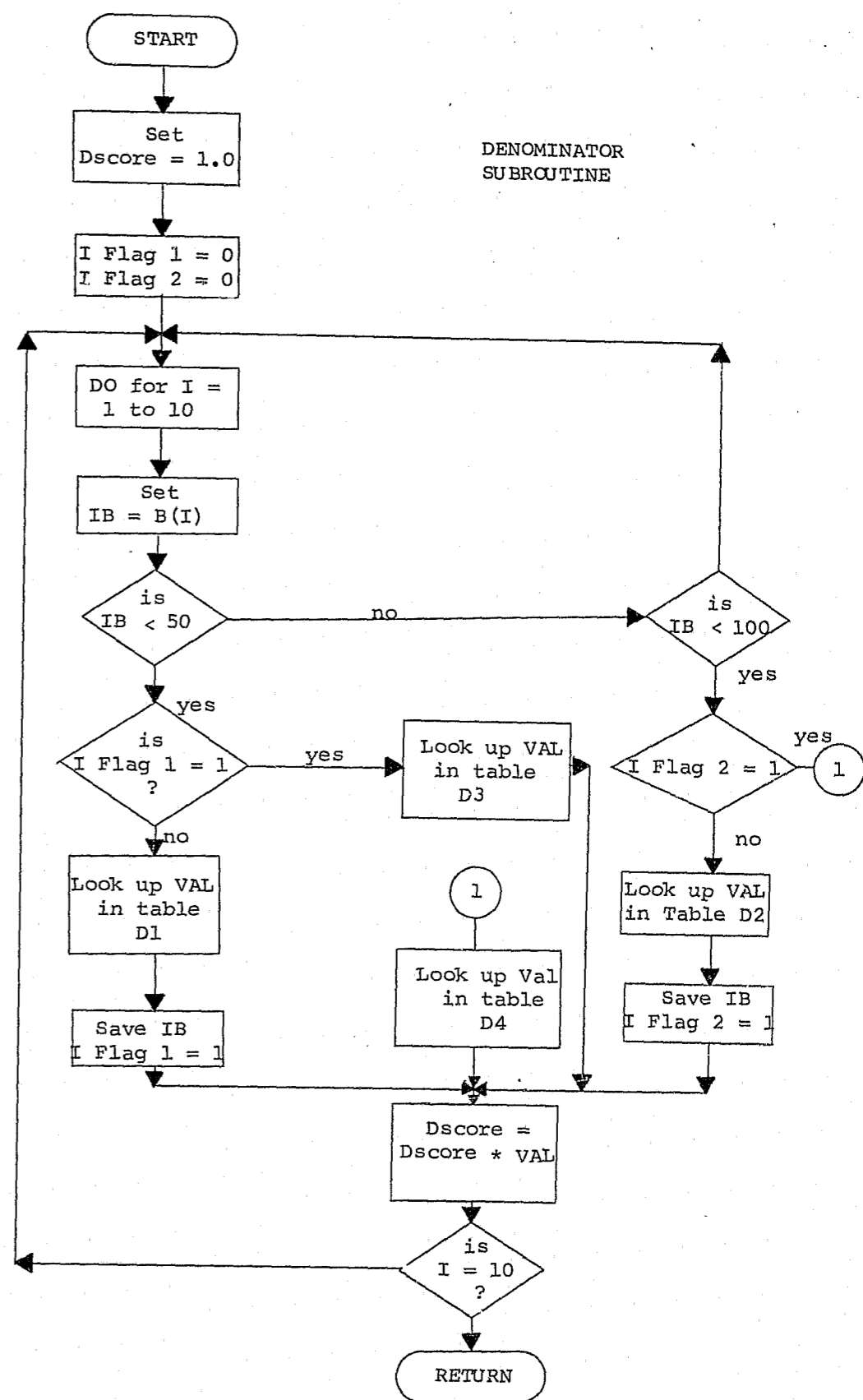

Exhibit B-11 (Continued)

SEARCH ARG

A(I,J)

THRESHOLD VALUES

0.3E-01 0.1E 00 0.3E 00 0.1E 01 0.3E 01 0.1E 02 0.3E 02 0.1E 03 0.3E 03 0.1E 04

Table with columns for SEARCH ARG, A(I,J), and 16 threshold values. Rows 61-100. Includes a vertical label 'B-68' on the left.

SEARCH ARG

A(I,J)

THRESHOLD VALUES

0.3E-01 0.1E 00 0.3E 00 0.1E 01 0.3E 01 0.1E 02 0.3E 02 0.1E 03 0.3E 03 0.1E 04

B-69

Table with columns for SEARCH ARG, A(I,J), and 16 threshold values. Rows 1-50.

Exhibit B-14 (Continued)

S I F T E R
MODE 2
DATA SET NUMBER 1

| | | | | | |
|----|--|------------------|------------------------------|--------|--------------|
| 15 | 05 TT TT 15 02 AA 52 TT 18 12 05 TT TT 15 03 AA 55 04 19 13 | NUMER= DENOM= | 0.974829E-09 0.471932E-14 | SCORE= | 0.206534E 08 |
| 16 | 24 DI 10 17 17 15 DO PH 17 17 24 DI 09 17 17 18 DO PH 16 16 | NUMER= DENOM= | 0.118994E-04 0.897850E-11 | SCORE= | 0.143570E 07 |
| 17 | PO PI 13 14 07 PI 20 11 14 09 PO CI 14 14 08 PI 20 12 13 10 | NUMER= DENOM= | 0.903515E-06 0.467829E-13 | SCORE= | 0.193212E 08 |
| 18 | 26 05 06 05 06 13 55 03 09 06 25 05 06 05 08 24 55 04 08 07 | NUMER= DENOM= | 0.557428E-06 0.578194E-15 | SCORE= | 0.064015E 09 |
| 19 | PO PI 06 05 08 PI 08 02 03 05 PO PM 07 07 06 PI 08 05 03 05 | NUMER= DENOM= | 0.407206E-06 0.966299E-12 | SCORE= | 0.421408E 06 |
| 20 | 16 11 07 PI 07 12 07 07 09 04 15 10 07 PI 07 13 07 07 09 04 | NUMER= DENOM= | 0.265476E-03 0.440603E-13 | SCORE= | 0.602529E 10 |
| 21 | 18 10 12 14 13 15 60 10 14 09 18 10 13 12 12 15 59 10 14 10 | NUMER= DENOM= | 0.177917E-05 0.127442E-12 | SCORE= | 0.139606E 08 |
| 22 | PO PI PO PI 15 19 CI 17 PI 15 PO PI PO PI 14 19 CI 16 PI 14 | NUMER= DENOM= | 0.289911E-02 0.859587E-06 | SCORE= | 0.337264E 06 |
| 23 | DO 15 13 CO 16 DI 13 17 PI 16 PO 15 13 CO 16 DI 13 16 PI 16 | NUMER= DENOM= | 0.166592E-03 0.372716E-10 | SCORE= | 0.500627E 07 |
| 24 | 02 04 04 05 05 AA TT 07 07 TT 02 04 04 05 04 AA TT 07 07 TT | NUMER= DENOM= | 0.146094E-02 0.202791E-12 | SCORE= | 0.720413E 10 |
| 25 | 17 17 14 17 12 DI 12 06 15 11 18 17 14 18 13 DI 13 06 15 10 | NUMER= DENOM= | 0.863256E-05 0.671197E-13 | SCORE= | 0.123614E 09 |
| 26 | 08 62 10 02 04 11 06 07 07 05 07 63 11 03 05 07 05 09 09 05 | NUMER= DENOM= | 0.122202E-11 0.682786E-14 | SCORE= | 0.178976E 03 |
| 27 | 10 04 TT 05 01 07 04 02 04 AA 10 04 TT 06 01 06 05 02 04 AA | NUMER= DENOM= | 0.169685E-03 0.147075E-13 | SCORE= | 0.115273E 11 |
| 28 | 11 04 06 13 09 11 04 06 06 10 11 04 05 13 09 11 04 06 07 11 | NUMER= DENOM= | 0.663448E-04 0.240096E-12 | SCORE= | 0.276326E 09 |

B-72

Exhibit B-14 (Continued)

S I F T E R
MODE 2
DATA SET NUMBER 1

| | | | | | |
|----|--|------------------|------------------------------|--------|--------------|
| 29 | 18 06 13 14 14 13 10 13 PI 15 17 06 12 13 14 14 09 13 CI 12 | NUMER= DENOM= | 0.602704E-08 0.353693E-11 | SCORE= | 0.181028E 04 |
| 30 | PO 11 05 11 02 PI 10 07 CI 05 PO 12 05 11 07 PI 10 06 CI 06 | NUMER= DENOM= | 0.316031E-04 0.184062E-10 | SCORE= | 0.171679E 07 |
| 31 | 20 13 12 17 18 16 PO 11 17 17 21 13 12 18 17 16 PO 11 21 18 | NUMER= DENOM= | 0.103500E-06 0.105122E-12 | SCORE= | 0.174634E 07 |
| 32 | 19 PI PO PM 10 15 PI PM PI 08 20 PI PO PM 10 18 PM PM PM 09 | NUMER= DENOM= | 0.373293E-07 0.259300E-09 | SCORE= | 0.143962E 03 |
| 33 | 21 17 14 14 10 20 PO 13 12 10 21 15 14 14 01 22 PI 13 11 10 | NUMER= DENOM= | 0.207740E-06 0.450121E-14 | SCORE= | 0.715473E 05 |
| 34 | PO PI 14 PO 17 PI PO 13 14 14 PO PI 14 CO 15 PI PO 13 14 14 | NUMER= DENOM= | 0.510273E-04 0.264296E-08 | SCORE= | 0.106615E 05 |
| 35 | 15 PI 10 PM 07 14 01 14 16 CI 14 PI 10 PM 07 17 01 15 18 CI | NUMER= DENOM= | 0.120065E-04 0.233913E-09 | SCORE= | 0.557311E 05 |
| 36 | PO 10 07 CO 14 PI 64 04 09 CI PO 11 08 CO 13 PI 66 04 11 CI | NUMER= DENOM= | 0.320900E-05 0.420346E-11 | SCORE= | 0.761277E 06 |
| 37 | 17 09 10 PM 15 12 11 11 18 CI 15 08 09 PM 15 11 11 09 18 CI | NUMER= DENOM= | 0.126711E-05 0.145040E-11 | SCORE= | 0.172623E 06 |
| 38 | PM 62 11 15 10 15 07 11 12 07 PM 61 10 11 07 13 07 10 10 08 | NUMER= DENOM= | 0.370730E-08 0.401482E-13 | SCORE= | 0.923403E 05 |
| 39 | 14 TT 01 04 06 15 15 TT 05 05 15 TT 01 04 06 15 17 TT 04 04 | NUMER= DENOM= | 0.511692E-01 0.358534E-11 | SCORE= | 0.162142E 04 |
| 40 | 00 PM 07 01 00 10 11 PI CI 14 00 PM 07 01 00 20 18 PI CI 14 | NUMER= DENOM= | 0.232147E-01 0.220039E-07 | SCORE= | 0.115677E 07 |
| 41 | 10 TT 15 04 07 17 15 15 14 09 10 TT 13 04 08 17 18 13 13 09 | NUMER= DENOM= | 0.305209E-04 0.690103E-13 | SCORE= | 0.442121E 09 |
| 42 | 19 52 05 62 12 10 53 05 17 14 18 03 06 60 17 09 52 05 16 11 | NUMER= DENOM= | 0.176608E-17 0.150127E-14 | SCORE= | 0.971229E 02 |

B-73

Exhibit B-14 (Continued)

S I F T E R
MODE 2
DATA SET NUMBER 1

| | | | | |
|----|--|------------------|------------------------------|------------------------|
| 43 | PI PI PI PI 19 PI PI 11 CI 15 FO PI PI PI 16 PI PI 15 CI 14 | NUMER= DENOM= | 0.441127E-03 0.134470E-06 | SCORE= 0.134470E-06 |
| 44 | PI 13 09 14 10 PI 10 14 12 09 14 14 10 15 10 PI 09 14 12 09 | NUMER= DENOM= | 0.161179E-04 0.131157E-11 | SCORE= 0.131157E-11 |
| 45 | DM PI 12 10 10 PI PI 15 PI 14 DM PI 13 10 10 PI PI 14 PI 14 | NUMER= DENOM= | 0.254779E-01 0.124007E-08 | SCORE= 0.124007E-08 |
| 46 | PI 63 14 10 21 08 TT 17 21 20 PI 61 14 22 21 08 TT 16 20 19 | NUMER= DENOM= | 0.203800E-09 0.752932E-14 | SCORE= 0.752932E-14 |
| 47 | 10 62 13 17 13 04 PC CI 17 13 11 62 13 16 13 03 PC PI 16 12 | NUMER= DENOM= | 0.422160E-05 0.306619E-14 | SCORE= 0.306619E-14 |
| 48 | 10 PL 10 01 PI PL PL 08 XI PI 17 PD 01 01 PC PC PL 09 XI PI | NUMER= DENOM= | 0.944190E-02 0.294803E-07 | SCORE= 0.294803E-07 |
| 49 | PI PI PD PD 16 LI PC PI PI 15 PI PI PD PD 15 DI PC PI PI 17 | NUMER= DENOM= | 0.418927E-04 0.145410E-05 | SCORE= 0.145410E-05 |
| 50 | 18 05 04 02 02 11 03 04 TT 02 19 05 04 02 02 11 03 03 TT 01 | NUMER= DENOM= | 0.124393E-04 0.332600E-14 | SCORE= 0.332600E-14 |
| 51 | PC DM 18 PC PC PC 02 14 PI PM PC DM 18 PM PC PM 03 14 PI PM | NUMER= DENOM= | 0.429411E-03 0.291354E-06 | SCORE= 0.291354E-06 |
| 52 | PC PM 15 PM CC PI PI 16 PI 10 PD PM 13 PM CC PI PI 16 PI 10 | NUMER= DENOM= | 0.502984E-02 0.197063E-07 | SCORE= 0.197063E-07 |
| 53 | PC DI PI PM PC DI PC PC PI 23 PD DI PI PM PC CI PC PD PI 23 | NUMER= DENOM= | 0.112352E-00 0.242774E-06 | SCORE= 0.242774E-06 |
| 54 | 07 11 09 15 08 07 55 07 10 04 07 11 09 15 08 06 55 05 11 05 | NUMER= DENOM= | 0.219048E-07 0.511922E-14 | SCORE= 0.511922E-14 |
| 55 | CC CI TT CC 05 21 13 03 CI 08 CC CI TT CC 04 21 13 04 CI 09 | NUMER= DENOM= | 0.361536E-03 0.251683E-11 | SCORE= 0.251683E-11 |
| 56 | 16 13 10 12 12 07 11 09 06 09 16 13 08 12 09 06 10 08 07 09 | NUMER= DENOM= | 0.683777E-08 0.125434E-12 | SCORE= 0.125434E-12 |

B-74

Exhibit B-14. (Continued)

S I F T E R
MODE 2
DATA SET NUMBER 1

| | | | | |
|----|--|------------------|------------------------------|------------------------|
| 57 | 16 11 11 06 TT 07 06 10 07 08 15 11 11 05 CM 07 07 10 07 09 | NUMER= DENOM= | 0.709986E-02 0.326962E-14 | SCORE= 0.326962E-14 |
| 58 | PD 07 15 PC 18 PM 00 DI PI DI PD 06 15 PC 18 PM 00 DI PI DI | NUMER= DENOM= | 0.992984E-02 0.107317E-08 | SCORE= 0.107317E-08 |
| 59 | 18 69 PI CC 14 16 14 09 21 12 17 68 PI CC 14 15 13 08 21 14 | NUMER= DENOM= | 0.767460E-06 0.196619E-13 | SCORE= 0.196619E-13 |
| 60 | AA AA AA AA AA AA AA AA AA TT AA AA AA TT AA AA AA AA AA TT | NUMER= DENOM= | 0.202030E-01 0.100000E-03 | SCORE= 0.100000E-03 |
| 61 | 17 SR 05 12 10 15 TT 02 14 09 17 TT 05 11 10 14 TT 01 14 09 | NUMER= DENOM= | 0.622940E-08 0.535731E-11 | SCORE= 0.535731E-11 |
| 62 | DM 55 TT PM PD 08 52 02 04 16 DM 56 TT PM PD 07 53 02 04 17 | NUMER= DENOM= | 0.349035E-10 0.364852E-12 | SCORE= 0.364852E-12 |
| 63 | 23 17 19 18 20 14 12 21 19 17 21 16 19 17 20 16 14 19 19 16 | NUMER= DENOM= | 0.520026E-08 0.416954E-12 | SCORE= 0.416954E-12 |
| 64 | PD XM 13 PC 12 PM 54 11 19 16 PD XO 12 PC 12 PM 54 11 18 14 | NUMER= DENOM= | 0.400501E-07 0.623403E-10 | SCORE= 0.623403E-10 |
| 65 | PC 09 TT 08 11 PD AA AA TT 03 PC 09 TT 08 12 PD AA AA TT 02 | NUMER= DENOM= | 0.261857E-02 0.136635E-09 | SCORE= 0.136635E-09 |
| 66 | PM PI 11 CC 14 PI PI 10 17 14 PM PI 12 CC 13 PI PI 11 16 13 | NUMER= DENOM= | 0.242055E-03 0.106778E-08 | SCORE= 0.106778E-08 |
| 67 | DC 02 11 03 16 22 02 02 03 16 DC TT 11 04 16 22 02 02 03 15 | NUMER= DENOM= | 0.875168E-04 0.436464E-15 | SCORE= 0.436464E-15 |
| 68 | 21 15 12 CC PM 16 PC 13 CI 15 10 16 12 CC PM 16 PD 13 CI 14 | NUMER= DENOM= | 0.674011E-03 0.883991E-10 | SCORE= 0.883991E-10 |
| 69 | 18 TT 01 26 10 14 06 12 03 26 18 TT 09 25 09 14 06 12 05 21 | NUMER= DENOM= | 0.477711E-12 0.856950E-16 | SCORE= 0.856950E-16 |
| 70 | PC PM 16 PI 16 22 PI 20 CI 17 PC PM 16 PI 16 22 PI 18 CI 17 | NUMER= DENOM= | 0.155447E-02 0.150095E-09 | SCORE= 0.150095E-09 |

B-75

Exhibit B-14 (Continued)

S I F T E R
MODE 1
DATA SET NUMBER 1

B-76

| | | | |
|----|-------------------------------------|---|---------------------|
| 71 | 13 01 10 11 12 13 14 15 16 17 18 19 | NUMER= 0.677147E-07 DENOM= 0.562572E-13 | SCORE= 0.120111E-07 |
| 72 | 01 02 03 04 05 06 07 08 09 10 11 12 | NUMER= 0.376441E-04 DENOM= 0.621011E-11 | SCORE= 0.607011E-07 |
| 73 | 15 08 09 10 11 12 13 14 15 16 17 18 | NUMER= 0.208719E-10 DENOM= 0.1617209E-13 | SCORE= 0.129490E-07 |
| 74 | 02 03 04 05 06 07 08 09 10 11 12 13 | NUMER= 0.114715E-06 DENOM= 0.442515E-10 | SCORE= 0.270070E-04 |
| 75 | 10 14 14 10 11 12 13 14 15 16 17 18 | NUMER= 0.557506E-06 DENOM= 0.115029E-12 | SCORE= 0.481721E-07 |
| 76 | 19 13 11 20 14 15 16 17 18 19 20 21 | NUMER= 0.125055E-04 DENOM= 0.534003E-12 | SCORE= 0.231474E-08 |
| 77 | 01 16 18 19 10 11 12 13 14 15 16 17 | NUMER= 0.245054E-02 DENOM= 0.203344E-12 | SCORE= 0.120277E-09 |
| 78 | 02 03 04 05 06 07 08 09 10 11 12 13 | NUMER= 0.193914E-01 DENOM= 0.768402E-10 | SCORE= 0.252364E-09 |
| 79 | 01 02 03 04 05 06 07 08 09 10 11 12 | NUMER= 0.215197E-00 DENOM= 0.356842E-05 | SCORE= 0.603059E-05 |
| 80 | 14 11 01 02 03 04 05 06 07 08 09 10 | NUMER= 0.135397E-02 DENOM= 0.192304E-12 | SCORE= 0.704078E-10 |
| 81 | 16 16 01 02 03 04 05 06 07 08 09 10 | NUMER= 0.199203E-02 DENOM= 0.117952E-09 | SCORE= 0.168969E-07 |
| 82 | 19 03 07 05 07 20 01 02 03 04 05 06 | NUMER= 0.172136E-09 DENOM= 0.147607E-13 | SCORE= 0.116610E-05 |
| 83 | 20 02 19 10 11 12 13 14 15 16 17 18 | NUMER= 0.918171E-03 DENOM= 0.193922E-12 | SCORE= 0.472478E-10 |
| 84 | 01 02 03 04 05 06 07 08 09 10 11 12 | NUMER= 0.748242E-05 DENOM= 0.200075E-15 | SCORE= 0.374030E-11 |

Exhibit B-14 (Continued)

S I F T E R
MODE 2
DATA SET NUMBER 1

B-77

| | | | |
|----|-------------------------------------|--|---------------------|
| 85 | 20 21 16 21 15 23 13 16 20 22 22 | NUMER= 0.649307E-05 DENOM= 0.407396E-13 | SCORE= 0.159380E-09 |
| 86 | 01 02 03 04 05 06 07 08 09 10 11 12 | NUMER= 0.922892E-03 DENOM= 0.115687E-09 | SCORE= 0.797748E-07 |
| 87 | 22 22 05 03 08 06 07 08 09 10 11 12 | NUMER= 0.193468E-12 DENOM= 0.412414E-15 | SCORE= 0.469112E-03 |
| 88 | 01 02 03 04 05 06 07 08 09 10 11 12 | NUMER= 0.345371E-05 DENOM= 0.113100E-09 | SCORE= 0.305368E-05 |
| 89 | 21 23 15 17 18 14 08 12 18 14 15 | NUMER= 0.146217E-06 DENOM= 0.348830E-13 | SCORE= 0.419163E-07 |
| 90 | 01 02 03 04 05 06 07 08 09 10 11 12 | NUMER= 0.520982E-07 DENOM= 0.409039E-11 | SCORE= 0.127367E-05 |
| 91 | 00 00 01 02 03 04 05 06 07 08 09 10 | NUMER= 0.350109E-02 DENOM= 0.749729E-05 | SCORE= 0.466981E-03 |
| 92 | 16 17 03 06 05 12 12 12 06 11 12 13 | NUMER= 0.642338E-04 DENOM= 0.302264E-10 | SCORE= 0.212509E-07 |
| 93 | 01 02 03 04 05 06 07 08 09 10 11 12 | NUMER= 0.166222E-03 DENOM= 0.369996E-07 | SCORE= 0.449254E-04 |
| 94 | 17 17 13 20 12 13 14 13 21 10 11 12 | NUMER= 0.111766E-03 DENOM= 0.692678E-13 | SCORE= 0.161354E-10 |
| 95 | 01 02 03 04 05 06 07 08 09 10 11 12 | NUMER= 0.887551E-13 DENOM= 0.928045E-06 | SCORE= 0.956366E-07 |
| 96 | 00 00 01 02 03 04 05 06 07 08 09 10 | NUMER= 0.120834E-06 DENOM= 0.231465E-12 | SCORE= 0.522042E-06 |
| 97 | 19 19 01 02 04 04 11 12 53 53 06 07 | NUMER= 0.305893E-07 DENOM= 0.501511E-14 | SCORE= 0.609942E-07 |
| 98 | 20 20 01 02 03 04 05 06 07 08 09 10 | NUMER= 0.338890E-08 DENOM= 0.102020E-09 | SCORE= 0.332162E-02 |

Exhibit B-14 (Continued)

S I F T E R
 MODE 2
 DATA SET NUMBER 1

| | | | | | |
|-----|-------------------------------|--------|--------------|--------|--------------|
| 99 | 22 DM 08 08 22 16 14 04 07 13 | NUMER= | 0.129654E-05 | SCORE= | 0.178391E 12 |
| | 21 DM 08 08 21 15 14 03 07 17 | DENOM= | 0.726797E-17 | | |
| 100 | 17 TT 12 15 12 19 56 14 14 09 | NUMER= | 0.291649E-09 | SCORE= | 0.116362E 04 |
| | 17 TT 12 15 13 19 58 12 12 10 | DENOM= | 0.250639E-12 | | |

B-78

Exhibit B-15

S I F T E R
 MODE 2
 DATA SET NUMBER 2

| | | | | | |
|----|-------------------------------|--------|--------------|--------|--------------|
| 1 | 17 16 14 17 07 10 08 13 15 11 | NUMER= | 0.364795E-07 | SCORE= | 0.436605E 06 |
| | 18 18 13 16 09 09 07 13 16 11 | DENOM= | 0.835527E-13 | | |
| 2 | 21 12 14 15 17 18 14 11 15 12 | NUMER= | 0.171544E-08 | SCORE= | 0.133695E 04 |
| | 21 11 13 16 15 16 12 09 14 12 | DENOM= | 0.128119E-11 | | |
| 3 | PO 04 10 14 07 PM CM 05 15 03 | NUMER= | 0.507151E-04 | SCORE= | 0.383521E 09 |
| | PO 05 10 15 08 PM CM 06 14 03 | DENOM= | 0.132236E-12 | | |
| 4 | PO CI 21 PI 20 XX PM 17 CI 15 | NUMER= | 0.661884E-06 | SCORE= | 0.294137E 02 |
| | PO PI 19 PI SR SR PM 16 PI 16 | DENOM= | 0.225026E-07 | | |
| 5 | PO PM 10 PO CO PI PM PI PI 16 | NUMER= | 0.135642E-03 | SCORE= | 0.158979E 03 |
| | PO PM 11 PO CO PI PI PI PI 13 | DENOM= | 0.853205E-06 | | |
| 6 | PO PI CO PO 13 PI PO PM CI 14 | NUMER= | 0.274565E-04 | SCORE= | 0.287302E 02 |
| | DO PI CO PO 13 DI PO PM CI 13 | DENOM= | 0.955665E-06 | | |
| 7 | 19 PM 18 PO PO 12 PI PI PI 15 | NUMER= | 0.102861E-05 | SCORE= | 0.526340E 03 |
| | 18 PM 16 PO PO 12 PI PO PI 17 | DENOM= | 0.195426E-08 | | |
| 8 | 21 02 13 CO 05 12 55 10 18 12 | NUMER= | 0.168783E-05 | SCORE= | 0.308278E 09 |
| | 23 02 15 CO 05 12 55 12 19 12 | DENOM= | 0.547504E-14 | | |
| 9 | 22 16 14 23 16 DI 65 05 05 18 | NUMER= | 0.246469E-06 | SCORE= | 0.164106E 10 |
| | 21 14 13 22 16 DI 64 05 07 19 | DENOM= | 0.150189E-15 | | |
| 10 | PO 58 01 CO 14 CI PO 02 04 14 | NUMER= | 0.304261E-03 | SCORE= | 0.751083E 07 |
| | PO 58 TT CO 14 CI PO TT 04 13 | DENOM= | 0.405096E-10 | | |
| 11 | 10 09 14 18 15 07 10 14 13 13 | NUMER= | 0.755289E-08 | SCORE= | 0.116178E 06 |
| | 10 10 12 19 13 07 12 14 16 12 | DENOM= | 0.650111E-13 | | |
| 12 | DO 15 03 10 06 DI 11 12 13 16 | NUMER= | 0.525161E-06 | SCORE= | 0.828576E 06 |
| | DO 12 03 11 06 DI 11 12 12 13 | DENOM= | 0.633812E-12 | | |
| 13 | PM CO 14 CO 12 PM PM CI PI CI | NUMER= | 0.973192E-06 | SCORE= | 0.109353E 02 |
| | PM CO 12 CO 12 PI PM 13 PI CI | DENOM= | 0.889954E-07 | | |
| 14 | 13 PO 12 10 14 PM PO 08 10 11 | NUMER= | 0.452503E-07 | SCORE= | 0.967511E 05 |
| | 14 PM 12 11 14 PM PO 05 09 11 | DENOM= | 0.467698E-12 | | |

B-79

Exhibit B-15 (Continued)

S I F T E R
MODE 2
DATA SET NUMBER 2

| | | | | | | | | | | | | | | |
|----|----------|----------|----------|----------|----------|----------|----------|----------|----------|----------|------------------|------------------------------|--------|--------------|
| 15 | DM EM | AA AA | AA AA | 12 11 | 09 10 | 65 64 | AA AA | 01 01 | TT TT | 08 08 | NUMER= DENOM= | 0.118302E-02 0.393476E-10 | SCORE= | 0.300660E 08 |
| 16 | PI PI | 12 14 | 12 14 | 21 20 | 17 19 | 13 12 | 09 09 | 16 17 | 21 21 | 15 15 | NUMER= DENOM= | 0.247542E-06 0.654487E-14 | SCORE= | 0.378224E 08 |
| 17 | XX XX | XX XX | XX XX | XX XX | XX XX | 18 17 | TT TT | 03 03 | 08 08 | 16 15 | NUMER= DENOM= | 0.203919E-02 0.495252E-09 | SCORE= | 0.411748E 07 |
| 18 | DO DO | PI PI | PM PO | PM PM | CG CC | DI DI | PL PG | PI PI | PI CI | CI CI | NUMER= DENOM= | 0.927346E-03 0.100000E-03 | SCORE= | 0.927346E 01 |
| 19 | 13 15 | 09 10 | 04 04 | PM PO | TT TT | 12 13 | 05 06 | 06 07 | PI PI | 02 02 | NUMER= DENOM= | 0.908110E-05 0.161494E-12 | SCORE= | 0.562318E 08 |
| 20 | PI PI | 67 65 | CI CI | 14 17 | 17 16 | PI PI | CC CC | 11 11 | 14 14 | 14 14 | NUMER= DENOM= | 0.286676E-05 0.210292E-10 | SCORE= | 0.136323E 06 |
| 21 | PI PI | PM PM | CO CO | PO CO | SR SR | PM PO | PM PM | SR SR | 16 17 | 14 15 | NUMER= DENOM= | 0.329074E-04 0.875682E-06 | SCORE= | 0.375792E 02 |
| 22 | DO DO | 09 09 | DO CO | PO PO | 14 13 | DI DI | DO DO | PM PI | PI PI | 16 15 | NUMER= DENOM= | 0.526640E-07 0.141001E-07 | SCORE= | 0.373500E 01 |
| 23 | 15 16 | 02 03 | 12 14 | 15 15 | 06 05 | 14 13 | 51 53 | 04 06 | 12 13 | 05 04 | NUMER= DENOM= | 0.532151E-11 0.723265E-13 | SCORE= | 0.735763E 02 |
| 24 | 13 13 | SR 68 | 13 13 | 13 14 | 13 13 | 13 13 | SR SR | 13 12 | 13 12 | 13 12 | NUMER= DENOM= | 0.884945E-06 0.366729E-13 | SCORE= | 0.241308E 08 |
| 25 | SR CO | 06 07 | 02 04 | 14 14 | TT TT | 04 06 | 05 04 | TT TT | 56 57 | TT TT | NUMER= DENOM= | 0.860999E-10 0.103720E-10 | SCORE= | 0.830115E 01 |
| 26 | 21 22 | TT TT | 14 14 | 23 23 | 07 05 | 16 13 | 06 06 | 11 10 | 14 14 | 12 09 | NUMER= DENOM= | 0.825546E-09 0.595896E-13 | SCORE= | 0.138538E 05 |
| 27 | 15 15 | AA AA | 01 TT | 08 08 | 01 01 | 02 02 | AA AA | 01 01 | 08 08 | 05 03 | NUMER= DENOM= | 0.858509E-05 0.211566E-13 | SCORE= | 0.405787E 09 |
| 28 | 18 19 | PI PI | PI PI | SR SR | 14 15 | 19 18 | PC PC | 13 13 | CI PI | 12 13 | NUMER= DENOM= | 0.509367E-04 0.650304E-09 | SCORE= | 0.783274E 05 |

OB-B

Exhibit B-15 (Continued)

S I F T E R
MODE 2
DATA SET NUMBER 2

| | | | | | | | | | | | | | | |
|----|----------|----------|----------|----------|----------|----------|----------|----------|----------|----------|------------------|------------------------------|--------|--------------|
| 29 | 25 25 | PI PI | 16 16 | 23 21 | 20 20 | 24 22 | PO PO | PI PI | 22 21 | 18 19 | NUMER= DENOM= | 0.688874E-05 0.103949E-11 | SCORE= | 0.662706E 07 |
| 30 | 14 15 | 60 60 | 08 08 | 13 15 | 09 10 | 14 13 | 06 06 | 12 14 | 15 16 | 11 11 | NUMER= DENOM= | 0.707518E-06 0.190679E-13 | SCORE= | 0.371051E 08 |
| 31 | 14 14 | 55 55 | TT TT | 03 02 | 09 10 | 12 11 | 52 52 | 03 03 | 05 04 | SR 08 | NUMER= DENOM= | 0.218368E-05 0.638146E-15 | SCORE= | 0.342191E 10 |
| 32 | 05 07 | 05 05 | AA AA | 09 09 | 05 06 | 04 05 | 60 62 | AA AA | 12 13 | 05 06 | NUMER= DENOM= | 0.137861E-04 0.140521E-13 | SCORE= | 0.981070E 09 |
| 33 | 04 03 | 02 03 | 04 05 | 05 05 | 09 10 | 05 06 | TT TT | SR SR | 05 06 | 11 10 | NUMER= DENOM= | 0.393258E-05 0.176177E-13 | SCORE= | 0.223218E 09 |
| 34 | AA AA | AA AA | 09 10 | 17 17 | 08 10 | AA AA | AA AA | 09 10 | 15 13 | 04 05 | NUMER= DENOM= | 0.208215E-04 0.982664E-10 | SCORE= | 0.211888E 06 |
| 35 | DO DO | 13 13 | 13 14 | PM PM | 10 11 | DI PI | 15 13 | 12 14 | PI PI | 12 10 | NUMER= DENOM= | 0.250002E-06 0.334609E-10 | SCORE= | 0.747147E 04 |
| 36 | PI PI | PI PI | 13 11 | 20 19 | 14 16 | SR PI | PM PM | 11 13 | 17 20 | 16 16 | NUMER= DENOM= | 0.772052E-08 0.565360E-10 | SCORE= | 0.136560E 03 |
| 37 | PO PO | 03 04 | 08 07 | CO PC | CO CO | PI PI | 02 02 | 03 02 | 11 10 | PI PI | NUMER= DENOM= | 0.206796E-04 0.150212E-09 | SCORE= | 0.137670E 06 |
| 38 | PO PO | 16 18 | 19 20 | 14 15 | 15 14 | DI CI | 15 13 | 15 16 | CI CI | 14 12 | NUMER= DENOM= | 0.328826E-06 0.376094E-12 | SCORE= | 0.874320E 06 |
| 39 | PO PI | CI CI | CI CI | PM PM | PM PM | PO PO | PM PM | PM PM | CI CI | 11 10 | NUMER= DENOM= | 0.605030E-04 0.616185E-05 | SCORE= | 0.981897E 01 |
| 40 | PO PM | PM PM | PM PM | PM PC | PC PI | PI PC | PC PC | PM PC | PI PI | 13 17 | NUMER= DENOM= | 0.169782E-04 0.521387E-05 | SCORE= | 0.325635E 01 |
| 41 | PO PO | PI PI | 14 14 | XX XX | XX XX | DI DI | SR SR | 13 13 | PM PI | CI 11 | NUMER= DENOM= | 0.441333E-05 0.861136E-07 | SCORE= | 0.512500E 02 |
| 42 | PO PO | 60 59 | 21 20 | PM PC | 22 22 | 22 25 | PI CI | 17 20 | 21 21 | 19 20 | NUMER= DENOM= | 0.136582E-09 0.509043E-13 | SCORE= | 0.268311E 04 |

IB-B

Exhibit B-15 (Continued)

S I F T E R
MODE 2
DATA SET NUMBER 2

B-82

| | | | | | |
|----|--|------------------|------------------------------|--------|--------------|
| 43 | PM 14 16 21 15 01 12 14 17 SR PM 15 17 21 15 01 12 14 17 14 | NUMER= DENOM= | 0.158473E-04 0.114621E-11 | SCORE= | 0.136258E 08 |
| 44 | DM 12 13 PC 12 01 10 17 18 09 DM 11 14 PC 12 01 09 14 PC 10 | NUMER= DENOM= | 0.638411E-09 0.200320E-10 | SCORE= | 0.418536E 02 |
| 45 | AA AA AA TT AA TT AA AA AA 03 AA AA AA TT AA TT AA AA AA 02 | NUMER= DENOM= | 0.303368E-01 0.146821E-05 | SCORE= | 0.206624E 05 |
| 46 | 14 09 08 14 12 13 02 10 PM 13 14 09 09 14 12 13 02 10 PM 13 | NUMER= DENOM= | 0.192633E-03 0.498883E-13 | SCORE= | 0.366128E 10 |
| 47 | 09 13 12 PC 14 09 07 13 13 11 10 13 12 CC 14 10 07 13 13 12 | NUMER= DENOM= | 0.230768E-05 0.590366E-12 | SCORE= | 0.390888E 07 |
| 48 | 21 09 19 17 19 21 17 10 17 16 20 10 18 18 19 23 17 08 17 18 | NUMER= DENOM= | 0.861559E-08 0.100427E-13 | SCORE= | 0.657897E 06 |
| 49 | 12 10 11 CC 07 04 10 17 13 04 12 09 10 CC 07 04 10 17 13 05 | NUMER= DENOM= | 0.324549E-04 0.444030E-14 | SCORE= | 0.730916E 10 |
| 50 | 13 07 11 09 04 12 07 12 10 06 14 09 11 09 04 14 08 14 10 06 | NUMER= DENOM= | 0.862493E-06 0.961644E-13 | SCORE= | 0.896895E 07 |
| 51 | 25 PM 13 07 07 23 14 10 05 16 26 PM 12 05 08 22 15 10 06 16 | NUMER= DENOM= | 0.170984E-06 0.239822E-15 | SCORE= | 0.712965E 09 |
| 52 | 12 04 08 08 06 13 03 05 05 05 14 03 08 10 08 13 04 05 06 05 | NUMER= DENOM= | 0.158966E-06 0.661825E-12 | SCORE= | 0.240194E 06 |
| 53 | 14 14 08 11 11 14 09 11 13 11 16 13 09 10 11 13 12 13 15 10 | NUMER= DENOM= | 0.896480E-09 0.570852E-12 | SCORE= | 0.157042E 04 |
| 54 | 14 06 08 08 12 16 05 10 09 58 16 06 08 08 13 17 04 11 11 00 | NUMER= DENOM= | 0.152537E-08 0.247816E-14 | SCORE= | 0.615525E 06 |
| 55 | 20 07 11 CM 07 13 10 13 11 08 20 07 13 CM 06 13 09 14 11 08 | NUMER= DENOM= | 0.195133E-05 0.186356E-13 | SCORE= | 0.104710E 09 |
| 56 | 14 09 09 13 11 11 02 08 13 06 16 09 09 13 11 11 02 08 13 06 | NUMER= DENOM= | 0.694211E-04 0.298860E-12 | SCORE= | 0.232286E 09 |

Exhibit B-15 (Continued)

S I F T E R
MODE 2
DATA SET NUMBER 2

B-83

| | | | | | |
|----|--|------------------|------------------------------|--------|--------------|
| 57 | 21 14 16 PO 12 DI 08 16 13 12 20 11 15 PO 12 DI 09 15 13 11 | NUMER= DENOM= | 0.434439E-06 0.749566E-13 | SCORE= | 0.579587E 07 |
| 58 | PO 06 08 08 08 12 05 07 09 11 PO 05 09 11 10 12 06 09 10 14 | NUMER= DENOM= | 0.139962E-08 0.368064E-12 | SCORE= | 0.380265E 04 |
| 59 | 07 09 PM 19 12 05 10 14 19 13 08 12 PM 19 11 05 10 15 18 14 | NUMER= DENOM= | 0.355844E-06 0.700052E-16 | SCORE= | 0.508311E 10 |
| 60 | 14 12 14 PM 11 15 13 17 17 14 15 13 15 PM 11 16 14 20 18 12 | NUMER= DENOM= | 0.691689E-07 0.240763E-13 | SCORE= | 0.287374E 07 |
| 61 | 16 PI 19 PO 16 11 14 14 CI 13 17 PI 19 PO 15 10 14 15 CI 14 | NUMER= DENOM= | 0.214142E-04 0.100779E-11 | SCORE= | 0.212487E 08 |
| 62 | 17 11 14 17 09 13 13 13 18 09 17 10 14 19 11 13 14 16 21 10 | NUMER= DENOM= | 0.343059E-08 0.975929E-13 | SCORE= | 0.351521E 05 |
| 63 | 12 11 13 14 16 15 09 14 16 16 13 12 14 15 16 15 09 14 18 17 | NUMER= DENOM= | 0.155229E-05 0.614698E-12 | SCORE= | 0.252529E 07 |
| 64 | 16 02 05 04 07 10 04 06 08 09 15 02 07 05 07 12 04 06 08 07 | NUMER= DENOM= | 0.132722E-06 0.897182E-12 | SCORE= | 0.147933E 06 |
| 65 | 08 11 09 PC 14 10 11 PO PI 08 06 11 10 PO 13 09 11 PO PI 08 | NUMER= DENOM= | 0.464012E-05 0.221934E-12 | SCORE= | 0.209076E 08 |
| 66 | DI AA 09 PI PO AA 08 11 PM PI DI AA 09 PI PO AA 07 11 PM PI | NUMER= DENOM= | 0.973066E-02 0.399105E-07 | SCORE= | 0.243612E 06 |
| 67 | PO 52 12 14 14 14 10 14 14 09 PO 53 12 13 15 14 09 13 16 11 | NUMER= DENOM= | 0.115143E-06 0.114468E-11 | SCORE= | 0.100590E 06 |
| 68 | 26 18 11 PO AA PO 14 17 PI 04 26 19 12 PO AA PO 14 18 PI 04 | NUMER= DENOM= | 0.582006E-03 0.246400E-11 | SCORE= | 0.236203E 09 |
| 69 | 18 59 10 DU 14 16 60 13 19 16 18 60 13 DU 16 17 62 13 20 15 | NUMER= DENOM= | 0.178213E-06 0.217719E-13 | SCORE= | 0.818548E 07 |
| 70 | PO PO 08 PI 13 PI PI PM PI 15 PO PO 09 PI 12 PI PI PM PI 14 | NUMER= DENOM= | 0.267056E-02 0.301221E-07 | SCORE= | 0.886577E 05 |

Exhibit B-15 (Continued)

S I F T E R
MODE 2
DATA SET NUMBER 2

| | | | | |
|----|--|------------------|------------------------------|------------------------|
| 71 | 16 03 14 15 09 AA 03 04 09 07 15 03 13 13 10 AA 04 04 10 10 | NUMER= DENOM= | 0.115676E-06 0.110954E-12 | SCORE= 0.104256E 07 |
| 72 | 16 11 09 13 12 14 07 05 CI CI 17 12 08 13 13 15 05 05 CI CI | NUMER= DENOM= | 0.504315E-06 0.277651E-13 | SCORE= 0.181636E 08 |
| 73 | 09 08 09 16 09 08 TT 10 PI 14 10 07 08 15 09 08 TT 11 PI 12 | NUMER= DENOM= | 0.170488E-05 0.767328E-13 | SCORE= 0.222183E 08 |
| 74 | PM TT 11 PM 15 DI AA 03 CI 12 PM 02 10 PM 15 DI AA 04 CI 12 | NUMER= DENOM= | 0.215644E-03 0.674929E-11 | SCORE= 0.319506E 08 |
| 75 | 08 03 09 12 08 16 02 09 14 11 07 03 09 12 09 14 TT 08 15 11 | NUMER= DENOM= | 0.524922E-06 0.172147E-12 | SCORE= 0.304927E 07 |
| 76 | 25 06 10 21 18 22 03 07 CI 16 28 06 10 20 15 22 05 TT CI 15 | NUMER= DENOM= | 0.117959E-12 0.374969E-14 | SCORE= 0.314583E 02 |
| 77 | 20 56 12 12 09 12 55 03 13 07 23 56 13 12 10 14 55 TT 12 08 | NUMER= DENOM= | 0.284024E-08 0.361099E-14 | SCORE= 0.766554E 06 |
| 78 | AA 59 04 CD 03 AA 05 06 PM 06 AA 57 03 CD 03 TT 07 05 PM 06 | NUMER= DENOM= | 0.224692E-06 0.302800E-11 | SCORE= 0.742048E 05 |
| 79 | AA 08 11 16 05 AA 04 08 11 03 AA 06 10 DI 04 AA 04 08 08 03 | NUMER= DENOM= | 0.205051E-08 0.143022E-11 | SCORE= 0.143370E 04 |
| 80 | 10 05 05 10 05 07 TT 03 06 07 13 05 06 10 04 07 TT TT 06 06 | NUMER= DENOM= | 0.277995E-06 0.439795E-12 | SCORE= 0.632101E 06 |
| 81 | PO 03 01 06 12 17 05 AA SR 10 PO 03 TT 04 12 14 05 AA SR SR | NUMER= DENOM= | 0.649052E-06 0.716961E-10 | SCORE= 0.905282E 04 |
| 82 | 13 62 57 CI CM 16 CM 11 PM 10 19 62 CI CI CM 16 CM 11 CM 11 | NUMER= DENOM= | 0.157554E-08 0.411124E-10 | SCORE= 0.383227E 02 |
| 83 | 17 PO CD PD 15 PI PI PI PI 16 17 PO PD PD 16 PI PI PI PI 17 | NUMER= DENOM= | 0.103589E-02 0.127269E-06 | SCORE= 0.813936E 04 |
| 84 | 09 07 02 19 11 07 TT AA 14 09 08 07 02 17 11 07 AA TT 15 10 | NUMER= DENOM= | 0.103028E-06 0.394602E-13 | SCORE= 0.261093E 07 |

B-84

Exhibit B-15 (Continued)

S I F T E R
MODE 2
DATA SET NUMBER 2

| | | | | |
|----|--|------------------|------------------------------|------------------------|
| 85 | 14 56 06 07 06 17 TT 09 11 05 14 TT 06 TT 05 14 TT 08 11 04 | NUMER= DENOM= | 0.284021E-13 0.162587E-12 | SCORE= 0.174689E 00 |
| 86 | 18 15 SR 20 13 16 12 13 17 17 17 14 TT 21 15 15 13 11 18 14 | NUMER= DENOM= | 0.557108E-09 0.179476E-12 | SCORE= 0.310409E 04 |
| 87 | PI PI CO PM 17 20 16 17 16 17 PO PI 21 PM 18 22 18 18 16 | NUMER= DENOM= | 0.137781E-10 0.590444E-12 | SCORE= 0.233351E 02 |
| 88 | PO XX PI PI DO PI PI PI PI 25 PO XX PI PI PO PI PI PI PI PI | NUMER= DENOM= | 0.116297E-04 0.100000E-03 | SCORE= 0.116297E 00 |
| 89 | 26 68 15 13 12 22 65 13 12 14 24 66 15 13 12 21 14 13 12 11 | NUMER= DENOM= | 0.412249E-11 0.343769E-14 | SCORE= 0.119920E 04 |
| 90 | 18 08 07 15 17 20 04 18 18 15 20 09 09 17 18 20 03 17 18 19 | NUMER= DENOM= | 0.521829E-09 0.125828E-12 | SCORE= 0.414716E 04 |
| 91 | PO PI PM PO PD 20 PD PI PI 17 PO PI PI PO PD 22 PD CI PI 21 | NUMER= DENOM= | 0.906019E-06 0.222583E-06 | SCORE= 0.407048E 01 |
| 92 | 21 15 16 15 16 15 05 12 15 13 22 13 14 12 16 19 05 15 19 15 | NUMER= DENOM= | 0.558192E-12 0.974726E-12 | SCORE= 0.572666E 00 |
| 93 | 23 03 07 SR 13 11 TT 02 52 10 19 03 06 SR 14 12 TT 02 54 08 | NUMER= DENOM= | 0.717427E-10 0.132857E-13 | SCORE= 0.539999E 04 |
| 94 | 24 18 18 PI 15 PI 19 16 PI CI 22 18 19 PI 16 PI 09 16 PI CI | NUMER= DENOM= | 0.343149E-06 0.370240E-11 | SCORE= 0.926829E 05 |
| 95 | 09 05 AA 04 11 05 TT TT 03 04 10 08 AA 04 15 06 TT TT 04 05 | NUMER= DENOM= | 0.153979E-06 0.611976E-13 | SCORE= 0.251609E 07 |
| 96 | 21 13 11 18 15 19 12 11 13 12 23 16 13 19 13 22 13 16 18 14 | NUMER= DENOM= | 0.384532E-13 0.594857E-12 | SCORE= 0.646427E-01 |
| 97 | PO PI 18 PO PD PI PO CI PI 18 PM PI 18 PO PD PI PO CI PI 17 | NUMER= DENOM= | 0.802591E-03 0.314553E-06 | SCORE= 0.255153E 04 |
| 98 | PO PI PO CO 16 PI PO PI PI 16 PO PI PO CO 15 PI PO PM PI 17 | NUMER= DENOM= | 0.619300E-03 0.727050E-06 | SCORE= 0.851799E 03 |

B-85

Exhibit B-15 (Continued)

S I F T E R
MODE 2
DATA SET NUMBER 2

| | | | | | | | | |
|-----|----------|-------|----------|-------|--------|--------------|--------|--------------|
| 99 | PO 12 12 | PO 15 | PI 10 15 | PI 10 | NUMER= | 0.446764E-03 | SCORE= | 0.321866E 07 |
| | PO 13 13 | PO 15 | PI 11 15 | PI 10 | DENOM= | 0.138804E-09 | | |
| 100 | 15 PH 11 | CO 11 | 10 15 10 | PI DI | NUMER= | 0.213281E-03 | SCORE= | 0.168697E 08 |
| | 15 PM 11 | CO 11 | 09 14 11 | FI DI | DENOM= | 0.126429E-10 | | |

B-86

67021 239 11-74 OSP 3M IDA

END