

NCJRS

SP43-20

This microfiche was produced from documents received for inclusion in the NCJRS data base. Since NCJRS cannot exercise control over the physical condition of the documents submitted, the individual frame quality will vary. The resolution chart on this frame may be used to evaluate the document quality.

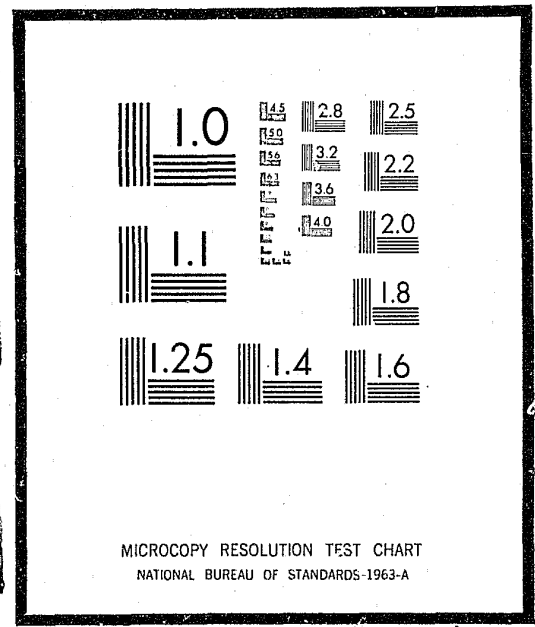

NATIONAL LAW ENFORCEMENT TELECOMMUNICATIONS NETWORK ANALYSIS— FINAL REPORT, PHASE II

Jet Propulsion Laboratory
California Institute of Technology
Pasadena, California 91103

Microfilming procedures used to create this fiche comply with the standards set forth in 41CFR 101-11.504

Points of view or opinions stated in this document are those of the author(s) and do not represent the official position or policies of the U.S. Department of Justice.

U.S. DEPARTMENT OF JUSTICE
LAW ENFORCEMENT ASSISTANCE ADMINISTRATION
NATIONAL CRIMINAL JUSTICE REFERENCE SERVICE
WASHINGTON, D.C. 20531

11/16/76

Date filmed

18167

Prepared for
Law Enforcement Assistance Administration
UNITED STATES DEPARTMENT OF JUSTICE

**NATIONAL LAW ENFORCEMENT
TELECOMMUNICATIONS
NETWORK ANALYSIS—
FINAL REPORT, PHASE II**

Norman B. Reilly
Glenn W. Garrison
Robert L. Sohn
Donald L. Gallop
Burton L. Goldstein

Jet Propulsion Laboratory
California Institute of Technology
Pasadena, California 91103

February 20, 1975

Prepared for
Law Enforcement Assistance Administration
UNITED STATES DEPARTMENT OF JUSTICE

ACKNOWLEDGMENT

The authors wish to express appreciation to Vasel Roberts, Dick Mathison, and Patrick Rygh for their constructive reviews of the completed document. It is also a pleasure to thank Fran Van Ness for her management of manuscript drafting and Ermine van der Wyk for her excellent direction of final manuscript production.

CONTENTS

- I. INTRODUCTION I-1
 - A. Purpose I-1
 - B. Scope I-1
 - C. Study Summary I-1
 - 1. Network Options Considered I-2
 - 2. Network Synthesis and Costing I-4
 - 3. Evaluation I-4
 - 4. Summary of Results I-4
- II. NETWORK DESIGN CRITERIA II-1
 - A. Functional Requirements II-1
 - 1. Digital Message Types II-1
 - 2. Message Identifiers II-1
 - 3. Message Lengths II-2
 - 4. Message Routing II-2
 - 5. Message Prioritization II-3
 - 6. Response-Time Goals II-3
 - 7. Message Coding II-4
 - 8. Error Detection II-4
 - 9. Network Status Messages II-4
 - 10. Network Statistics II-4
 - 11. Availability II-5
 - 12. Video Requirements II-5
 - B. Design Guidelines II-5
 - 1. Data Handling Constraints II-5
 - 2. Communication Line Constraints II-6
 - 3. Interfaces II-6
 - 4. Implementation Constraints II-6
 - 5. Staffing II-6
 - 6. Line Costs II-7
 - 7. Dollar Values II-7
 - 8. Network Life and Upgrading II-7
 - 9. Backup Power Supplies II-8
 - 10. Lease vs Buy II-8
 - C. Traffic II-8
 - 1. Best Estimate II-8
 - D. Redundancy II-9
 - E. Multiplexing II-12

CONTENTS (contd)

F.	Line Protocol	II-13
	1. Half Duplex	II-13
	2. Full Duplex	II-14
III.	NETWORK TOPOLOGY	III-1
	A. Selection of Regions	III-1
	B. Inter-Region Line Selection	III-2
	C. Inter-Region Line Selection	III-5
	D. Inter-Region Line Optimization	III-6
IV.	EVALUATION CRITERIA	IV-1
	A. Cost	IV-1
	B. Technical Criteria	IV-3
	1. Response Time	IV-3
	2. Reliability	IV-3
	3. Subjective Technical Evaluation Criteria	IV-4
	C. Non-Technical Criteria	IV-7
V.	DETAILS OF EACH OPTION	V-1
	1. Option 1	V-1
	2. Option 2	V-8
	3. Option 3	V-14
	4. Option 4	V-19
	5. Option 5	V-21
	6. Option 6	V-28
	7. Option 7	V-30
	8. Option 8	V-42
	9. Option 9	V-46
VI.	EVALUATION SUMMARY	VI-1
	A. Cost	VI-1
	B. Response Times	VI-3
	C. Reliability	VI-3

CONTENTS (contd)

D.	Technical Evaluation Criteria	VI-4
	1. Flexibility	VI-4
	2. Ease of Implementation	VI-4
	3. Simplicity	VI-6
	4. Privacy	VI-6
	5. Security	VI-6
E.	Required Network Selection Date	VI-7
F.	Minimum Traffic Analysis	VI-8
G.	NLETS VS NALECOM Protocol Comparison	VI-10
H.	Lease VS Buy Policy	VI-13
	1. Modems	VI-13
	2. Computer Hardware	VI-13
I.	NCIC Location Analysis	VI-17
VII.	CONCLUSIONS	VII-1
	A. General Conclusions	VII-1
	B. Ranking by Evaluation Criteria	VII-1
	1. Cost	VII-1
	2. Rating by Technical Evaluation Criteria	VII-2
	C. Network Selection	VII-3
Appenuixes		
A.	Traffic Requirements	A-1
B.	Communication Line Costs	B-1
C.	Switcher Configurations and Cost Bases	C-1
D.	Microwave Costs	D-1
E.	Satellite System Configuration and Cost	E-1
F.	Other Cost Factors	F-1
G.	Delay Analysis	G-1
H.	Availability Analysis	H-1
I.	Cost Detail Backup	I-1
J.	Evaluation Criteria Backup	J-1
K.	Glossary of Terms and Acronyms	K-1
References		

CONTENTS (contd)

TABLES

1.	Traffic estimates by year	II-9
2.	State-national traffic projections (best estimate)	II-11
3.	State-state traffic projections (best estimate)	II-12
4.	Average message lengths (1983 traffic)	II-13
5.	Cost items	IV-2
6.	Evaluation form	IV-5
7.	Inter-region line assignments	V-25
8.	Four phases of implementation	V-32
9.	Installation and operational periods	V-41
10.	Inter-region line assignments: 1983	V-44
11.	Best and minimum estimates: total traffic comparison (values in kilobits per second)	VI-10
12.	Sensitivity of cost to traffic	VI-10
13.	Lease-vs-buy tradeoff: 2400-bps modems	VI-15
14.	Lease-vs-buy tradeoff: 4800-bps modems	VI-15
15.	Lease-vs-buy tradeoff: 7200-bps modems	VI-16
16.	Lease-vs-buy tradeoff: 9600-bps modems	VI-16
A-1.	Summary of NALECOM traffic projections for 1983 ^a (best estimate)	A-2
A-2.	State-national traffic projections (best estimate)	A-5
A-3.	State-state traffic projections (best estimate)	A-5
A-4.	State-national traffic projections (minimum estimate)	A-6
A-5.	State-state traffic projections (minimum estimate)	A-6
A-6.	State-national message length distributions (best estimate)	A-7
A-7.	State-state message length distributions	A-8

CONTENTS (contd)

TABLES (contd)

A-8.	MTD traffic estimates	A-12
B-1.	Line mileage and service terminal costs	B-2
B-2.	Modem and line conditioning costs	B-4
B-3.	Sample calculation	B-4
B-4.	2400-bps international link costs	B-5
B-5.	Sample calculation	B-5
B-6.	Costs for four 2.4-kbps lines multiplexed on one 9.6-kbps line	B-9
B-7.	Costs for two 2.4-kbps users multiplexed on one 4.8-kbps line	B-10
B-8.	MUX configuration	B-12
B-9.	MUX configuration	B-13
B-10.	MUX configuration	B-14
B-11.	MUX configuration	B-15
B-12.	MUX configuration	B-16
B-13.	MUX configuration	B-17
B-14.	MUX configuration	B-18
B-15.	Numerical designations used for system terminations	B-19
C-1.	Operations center equipment	C-7
C-2.	Software costs	C-8
C-3.	Configuration A	C-9
C-4.	Configuration B	C-10
C-5.	Configuration C	C-11
C-6.	Costs for option 2	C-14

CONTENTS (contd)

TABLES (contd)

C-7.	Costs for options 4 and 7	C-14
D-1.	Costs for terminal-satellite location	D-2
D-2.	Costs for terminal-metropolitan location	D-3
D-3.	Repeater costs	D-4
D-4.	Equipment cost summary	D-5
E-1.	Uplink design: video uplink from NALECOM ground station to WESTAR-type spacecraft	E-5
E-2.	Downlink design: video downlink from WESTAR-type spacecraft to NALECOM ground station	E-6
E-3.	Satellite ground station cost estimate standard ground station	E-8
E-4.	Cost summary	E-9
F-1.	Personnel at major switcher centers	F-3
F-2.	Engineering tasks	F-4
F-3.	Total engineering man-hours and costs by option	F-5
G-1.	Response-time requirements	G-1
G-2.	State-to-RSC message characteristics	G-3
G-3.	State-to-RSC delay calculations	G-6
G-4.	Average delay for state-to-RSC links	G-6
G-5.	Inter-region message statistics	G-7
G-6.	Delay values for inter-region links at 4800 bps	G-7
G-7.	Total delays for worst link	G-8
H-1.	Availability estimates	H-3
H-2.	Availability summary	H-6
J-1.	Evaluation Form	J-2

CONTENTS (contd)

FIGURES

1.	NALECOM traffic summary	II-10
2.	Network optimization: selection of regions	III-3
3.	Network optimization: location of regional switcher	III-4
4.	Network optimization: inter-region network selection	III-7
5.	Option 1. State-to-state network configuration: 1979-1983	V-2
6.	Option 1. State-to-national network MUX configuration: 1980-1983	V-3
7.	Option 1. Overlay of separate state and national network configurations: 1979-1983	V-4
8.	Cost details	V-6
9.	Cost details	V-7
10.	Option 2. Network topology configuration: 1979-1983	V-9
11.	Cost details	V-11
12.	Cost details	V-12
13.	Cost details	V-13
14.	Option 3. Network topology configuration: 1979-1983	V-15
15.	Cost details	V-17
16.	Cost details	V-18
17.	Option 4. Two-region network	V-20
18.	Cost details	V-22
19.	Cost details	V-23
20.	Option 5. Five-region network configuration: 1979-1983	V-24
21.	Cost details	V-27

CONTENTS (contd)

FIGURES

22.	Option 6. 50-switcher network configuration: 1979-1983 .	V-29
23.	Cost details.	V-31
24.	Option 7. Typical data communications configuration for a western state in phases 7-a and 7-c	V-34
25.	Option 7. Phase 7-b network configuration	V-35
26.	Option 7. Phase 7-c network configuration	V-36
27.	Option 7. Phase 7-d network configuration	V-37
28.	Typical ground station.	V-39
29.	Cost details.	V-40
30.	Option 8. Ten-region network configuration: 1979-1983. .	V-43
31.	Cost details.	V-45
32.	Option 9. 25-switcher network configuration: 1979-1983.	V-47
33.	Cost details.	V-49
34.	Network comparison matrix	VI-2
35.	Total cost summary	VI-2
36.	Evaluation summary	VI-5
37.	National traffic projections	VI-8
38.	NLETS delay estimates	VI-9
39.	NLETS vs NALECOM: state-to-region delay, 500mi	VI-12
40.	NLETS vs NALECOM: state-to-region delay, 1000mi . .	VI-12
41.	Modem lease-vs-buy crossover range	VI-14
A-1.	State-national traffic estimates: transactions.	A-10
A-2.	State-state traffic estimates: messages per year	A-10
A-3.	State-state traffic estimates	A-11

CONTENTS (contd)

FIGURES

B-1.	Components of a typical communication line	B-2
C-1.	Regional message switcher functional block diagram	C-3
C-2.	Message switcher functional block diagram.	C-5
E-1.	Typical data communications configuration for a western state with satellite capability	E-2
E-2.	Typical ground station block diagram	E-3
G-1.	Worst link configuration	G-3
G-2.	Worst-case link delay values	G-8
H-1.	Availability calculations for series element	H-2
H-2.	Availability calculation for two parallel elements	H-2
H-3.	Availability calculation for redundant RSC computer, (a) Availability block diagram. (b) Total availability calculation.	H-4
H-4.	Availability calculation for non-redundant SSC computer (a) Availability block diagram. (b) Total availability calculation.	H-5
H-5.	Availability for options 1, 2, and 3	H-7
H-6.	Availability for options 4 and 7	H-7
H-7.	Availability for options 5 and 8	H-8
H-8.	Availability for options 6 and 9	H-9

SECTION I INTRODUCTION

A. PURPOSE

This document is the Final Report for Phase II of the National Law Enforcement Communications (NALECOM) study conducted by the Jet Propulsion Laboratory (JPL) for the Law Enforcement Assistance Administration (LEAA).

The purpose of this report is to document the analysis of nine alternative approaches to the NALECOM Network, and to provide the necessary information to allow the selection of a specific NALECOM Network configuration.

The work was sponsored through an inter-agency agreement with the National Aeronautics and Space Administration through Contract NAS7-100. The document provides technical material covering the network analysis/evaluation portion of the study, which was the major Phase II effort. Reference 1 is the Work Plan for the Phase II study. This document covers results of tasks C-4 through C-8 of that plan.

B. SCOPE

The network analysis/evaluation study was concerned with design and evaluation of nine different network configurations. Each configuration is capable of handling the state-to-state (S-S) and state-to-national (S-N) criminal justice traffic given in Ref. 2 and discussed in detail in Appendix A of this document.

Section II consists of functional requirements, design guidelines, and other factors that define a starting point for network analysis. Sections III and IV describe the approaches to analysis and evaluation. Sections V and VI detail specific results of the analyses and evaluations performed for all options, and Section VII presents conclusions.

A Glossary of Terms and Acronyms is presented in Appendix K.

The format used provides coverage of the study at three levels:

- 1) For basic study content and conclusions, the Introduction (Section I) and Conclusions (Section VII).
- 2) For a more detailed coverage, the entire main body of the report.
- 3) For technical depth, the Appendices in which major facets of the analyses are covered in depth.

C. STUDY SUMMARY

Nine network options, ranging from existing configurations to multi-regional distributed networks, were identified. Topologies were analyzed, and equipment and personnel requirements for each option were defined in accordance with NALECOM functional specifications and design guidelines. Evaluation criteria were developed and applied to each of the options leading to specific conclusions. The subsequent paragraphs highlight this sequence.

1. Network Options Considered

The nine options considered in this document range from the upgrading of existing networks using one computerized switcher to the implementation of multi-regional multi-computer networks. All networks handle digital message traffic using terrestrial communication lines leased from common carriers and message switching computers (message concentrators) to control routing through the network. One option provides satellite video and digital data-handling capability to be implemented subsequent to the initial development of the terrestrial capability. The options considered are:

Option	Topology and concept	Figure
1	Consists of two nationwide networks using one computer center in each net. State-to-state traffic is routed through Phoenix, Arizona, and state-to-national traffic through Washington, D. C.	7
2	Single-region network covering the entire United States. The switcher is located in Phoenix and handles both state-to-state and state-to-national traffic.	10
3	Single-region network covering the entire United States. The switcher is located in Washington, D. C. and handles state-to-state and state-to-national traffic.	14
4	Two-region configuration with one switcher in Phoenix handling traffic for western states and one switcher in Washington, D. C. handling traffic for eastern states. Regions are interconnected through lines between the switchers.	17
5	Five-region configuration with switchers located in capital cities of Colorado, Illinois, Georgia, New York, and Washington, D. C.	20
6	Fifty-switcher configuration with five major interconnected regional switchers located as in option 5, plus state switchers located in the capital cities of each state except Alaska and Hawaii. State switchers are interconnected in loops within each of the five major regions.	22
7	Initial configuration is as in option 4, the two-region case. This is referred to as option 7-a. Option 7 also provides for later addition of satellite data and video capability and eventual phaseout of the western switcher. This implementation is carried out in three phases: 7-b, 7-c, and 7-d.	17, 25 26, 27
8	Ten-region configuration with switchers located in capital cities of California, Colorado, Texas, Florida, Maryland, New York, Massachusetts, Ohio, Illinois, and Washington, D. C.	30

Option	Topology and concept	Figure
9	Twenty-five-switcher configuration with five major inter-connected regional switchers located as in option 5, plus state switchers located in the capitals of 20 other high traffic states. State switchers are interconnected in loops within each of the five major regions.	32

This range of options was selected to allow a thorough analysis of the broad spectrum of communications systems configurations, i.e., from single star networks serving the whole country to highly distributed networks. The approach provides an opportunity to assess characteristics such as cost, reliability, security, privacy, and other evaluation criteria across a range of configurations that meet NALECOM requirements.

2. Network Synthesis and Costing

Topologies for each option were derived using a topology computer program developed at JPL for the NALECOM study. The program is described in Section III.

For each of the topologies derived, requirements for communication lines, computer hardware/software, facilities, personnel, and engineering were determined and costed. Costs are presented in terms of one-time and recurring costs. Topology and cost details for each option are given in Section V.

3. Evaluation

Evaluation of the nine options was performed on the basis of cost, and technical criteria (response times, reliability, flexibility, ease of implementation, simplicity, privacy, and security). A description of these evaluation criteria is presented in more detail in Section IV. Evaluation results are given in Section VI.

4. Summary of Results

a. Cost. On a cost basis, the nine options considered rated in the following order:

Option	Cost, dollars	Option	Cost, dollars
3	8,000,000	1	12,200,000
4	8,200,000	9	16,000,000
5	9,500,000	6	25,000,000
2	10,100,000	7	34,500,000
8	11,700,000		

b. Technical Criteria Evaluation. Reliability and response-time requirements for the NALECOM Network were sufficient in all nine options, and therefore were not included in evaluation. The evaluation was based on a scale from 0 to 100, where 100 is the highest possible rating and a rating of 50 is acceptable. For the remaining five technical criteria the options ranked in the following order:

Option	Evaluation of five technical criteria (scale of 0 to 100)
2, 3	63
1	59
4	57
7	54
5	43
8	35
9	27
6	25

c. Non-Technical Evaluation. Final determination of rating for the non-technical criteria of acceptability and ease of management selection described in Section IV, or of the relative importance of these criteria to purely technical considerations is not within the scope of this report, nor within the province of JPL. These criteria are political in nature. Actual network users should have a strong input in this area of evaluation.

SECTION II
NETWORK DESIGN CRITERIA

A. FUNCTIONAL REQUIREMENTS

This subsection excerpts or updates major functional requirements from the NALECOM Functional Requirements Document (see Ref. 3). Where requirements conflict, this document applies. NALECOM Network user guidelines are presented in Ref. 4.

1. Digital Message Types

The NALECOM Network handles the following five basic types of messages.

- a) Data file interrogations/updates. These messages are inquiries, responses, entries, updates, and modifiers to and/or from data files at state or national levels. The text is generally in fixed format.
- b) Administrative messages. These messages are of an informal nature. The text is in free form.
- c) Fingerprints/graphics. These messages are digitized representations of fingerprints, a page of text, graph, etc. These messages can utilize the transparent text mode for transmission.
- d) Network status. These messages provide information regarding the status of all communication lines and alert network users in the event that lines are unable to function, or function in a degraded mode.
- e) Error messages. These messages indicate errors in format.

2. Message Identifiers

All messages contain the following information in known locations:

- a) Message type.
- b) Origin.

- c) Destination.
- d) Message sequence number.
- e) Segment number (normally used only for multi-segment messages).

3. Message Lengths

Messages are 400 characters in length or less with the exception of criminal histories or administrative messages, which do not exceed 1000 characters. Actual messages longer than specified will be broken down by the sender and sent as multi-segment messages not to exceed the above specified lengths. Messages exceeding the above length specifications will be rejected by the network. Message sequence and segment numbers are used by the destination terminal to reassemble such messages upon reception.

4. Message Routing

The NALECOM Network provides communications routing for data inquiries, administrative messages, and digitized graphic data between any of its system terminations.

For inquiries and administrative messages the following specific routing capability is provided:

- a) From any one system termination to any other, or up to five other system terminations.
- b) From any system termination to all other system terminations serviced by the regional switcher in which the message was generated.
- c) From any system termination to all other system terminations in the NALECOM Network.

The NALECOM Network provides for routing of digitized graphic data from any one system termination to any other single system termination. The NALECOM Network also provides routing of digitized fingerprint data from any system termination point to the National Crime Information Center (NCIC).

5. Message Prioritization

Messages are handled on a nonpreemptive priority basis. In this scheme, messages or message segments in the process of being transmitted will not be interrupted, but allowed to complete before higher-priority messages are honored. System terminations external to the NALECOM boundary should adhere to the same priority scheme in order to realize network response-time goals.

The NALECOM Network is capable of recognizing and handling message types in accordance with three priorities. Priority 1 is the highest priority.

Priority 1: Items that can be directly related to officer safety, such as inquiries or responses on stolen vehicles or property, wants and warrants, and vehicle registrations.

Priority 2: Administrative messages, computerized criminal histories and other message types not included in Priorities 1 and 3.

Priority 3: Graphic or fingerprint data consisting of large numbers of message segments.

Assignment of message types by the NALECOM Network to a given priority level is under software control and changeable by the operator.

6. Response-Time Goals

Response times for the NALECOM Network are defined as the time interval from the entry of the first message bit at a network system termination to the time the message is completed at the addressed system termination. To ensure desired response-time goals, lines are constrained so that system termination interfaces are no less than 2400 bps and that no more than three 2400-bps links occur in series during message transmission from one system termination to any other system termination. As a result of these line constraints, the average message transmission time for the worst routing in any network does not exceed the following response times:

Priority 1: 3.0 s

Priority 2: 7.5 s

Priority 3: 30.0 s

7. Message Coding

All NALECOM Network input and output messages are coded using the American Standard Code for Information Interchange (ASCII), as given in Ref. 5.

8. Error Detection

The NALECOM Network provides for bit error detection and automatic retransmission of erroneous messages. Specifically, the regional switcher has the capability of detecting errors and causing the transmitting station to retransmit errant messages. The regional switcher also retransmits messages to system terminations upon reception of a negative acknowledgment from system terminations. Half-duplex data links use a combination of vertical redundancy checking (VRC) and longitudinal redundancy checking (LRC). Full-duplex data links use a 16-bit cyclic redundancy check (CRC) as described in Ref. 6.

9. Network Status Messages

The NALECOM Network provides for notification to system terminations of any conditions that prevent operation in the normal specified manner.

10. Network Statistics

The NALECOM Network maintains statistics on message handling by origin-destination pairs and on single-circuit activity. The time period for statistics accumulation is controllable.

a. Origin-Destination Statistics. Origin-destination (O-D) message statistics are maintained for:

- 1) Number of messages by priority.
- 2) Average message length by priority.

In one-region cases, message statistics are maintained by message type.

b. Single-Circuit Statistics. Statistics are maintained for each NALECOM circuit by circuit number and direction for:

- 1) Number of messages.
- 2) Average message length.
- 3) Average and maximum queue lengths.
- 4) Number of queue overflows.
- 5) Average time spent in queue.
- 6) Number of message retransmissions.

11. Availability

The NALECOM Network will be in service 7 days/week, 24 h/day. The availability goal for any given O-D pair is 0.993. This implies that the average outage (complete disconnect) for a specific O-D pair is less than 10 min/day.

12. Video Requirements

Exact usage and functional requirements for video are not presently fully defined, and no basic requirements exist for video at this time. Option 7, however, does provide for real-time video at all system terminations to be equipped with satellite transmission/reception capability. Video from any one of 14 such locations can be transmitted directly to all others. Video also can be used for intra-state functions in those instances where additional facilities are available in the state. Video links will be designed with a signal-to-noise ratio (peak-to-peak picture/weighted RMS noise) equal to or greater than 54 dB.

B. DESIGN GUIDELINES

1. Data Handling Constraints

- a) All data transmission is digital.
- b) No unscrambling or decryption is performed within the NALECOM Network; therefore, message headers and control sequences will not

be scrambled or encrypted by network users. (Some modems perform scrambling in the normal course of their operation, but this scrambling is invisible to the user.)

- c) Traffic loading by network users on a sustained basis in excess of the traffic for which their system terminations are designed could result in degraded message response time.

2. Communication Line Constraints

a. Line Speed. The minimum service provided is a 2400-baud synchronous transmission, half-duplex, four-wire system using contention-type line control. Data rates of 2400, 4800, 7200, and 9600 bps or combinations of these rates are used on system termination interfaces, as traffic requires.

b. Bit Error Rate. Networks will be designed assuming bit error rates less than 1×10^{-5} .

3. Interfaces

NALECOM interfaces will be provided at each state capital, Washington, D. C., and the NCIC (in Washington, D. C.).

4. Implementation Constraints

Prime communication lines and all network hardware are dedicated. Backup dial-up lines are used with multiplexing to maintain availability at a high level.

The phaseover of existing communication services to NALECOM communication services must be accomplished without degrading or interrupting service.

5. Staffing

In multi-switcher options, one regional switcher is designated as the master switcher. Master switchers are staffed with two persons continuously. To staff a facility 24 h/day throughout the year with two persons requires ten

persons. Staffing is assumed to be eight computer operators and two computer programmers. A supervisor is also provided, bringing the total staff at master switchers to 11.

Subsequent switchers are staffed at 1 man-year per switcher. In practice, this person can either be resident during a normal 8-h day, or can be on call if this availability is adequate.

6. Line Costs

General Services Administration (GSA) TELPAK line costs are used in pricing line services. Line cost details are presented in Appendix B.

7. Dollar Values

Costing of network facilities is figured using 1974 dollars. There is no built-in inflation factor.

8. Network Life and Upgrading

Network pricing is based upon a 7-year period of operation from January 1977 through December 1983. There is a considerable growth in traffic over this period of time, and thus a change in line requirements. The networks are initially designed for projected December 1979 traffic and will operate in this configuration from January 1977 through December 1979. A single network upgrade will be performed in 1979 and become operational in 1980. At this point, lines are upgraded to meet increased traffic levels where required. The network will remain in this configuration through 1983.

Complete computer interfaces required in 1983 are installed at the outset in 1976; however, maintenance on the interfaces is paid for on an as used basis. These criteria are reflected in an increase in recurring costs for switchers and lines in 1980, the first operational year of the upgrade.

9. Backup Power Supplies

Uninterruptible power supplies (UPS) are provided at each regional switcher. These supplies provide support to commercial power during momentary transients using a battery inverter system and indefinite total power backup through a diesel generator when total commercial power outage is observed.

All UPS are sized at 10 kVA for convenience. The UPS cost is a small fraction of total costs, and selection of units specifically sized to each switcher's requirements would not have a significant cost impact.

10. Lease vs Buy

The policy was adapted to buy computer hardware and to lease modems, multiplexers, and facilities. Rationale for the adoption of this policy is presented in Section VI.

C. TRAFFIC

1. Best Estimate

The NALECOM Network is designed to handle traffic projections through 1983. These projections are increased by a factor of 2 for peak vs average loading. The total network projections for 1975 through 1983 are given in Table 1. Traffic is divided to show state-to-national (S-N), national-to-state (N-S), and state-to-state (S-S) traffic in kilobits per second. These estimates are described in Ref. 2 and in Appendix A of this document.

The six principal categories of traffic are shown in Fig. 1. The current uses category includes projected growth in the use of mobile digital terminals (MDT). The figure indicates a traffic growth of approximately twenty-fold over the 10-year period from 1975 to 1983. Table 2 gives the S-N and N-S traffic projections from 1975 to 1983 in terms of messages per year and kilobits per second for each of the six categories. State-to-state traffic projections are given in Table 3. The numbers shown in these figures do not include the factor of 2 for peak-to-average loading.

Table 1. Traffic estimates by year

Routing	1975	1977	1979	1981	1983
S-N	2.0	3.9	8.6	18.3	24.9
N-S	3.2	8.9	17.8	24.7	32.4
S-S	1.4	2.6	5.9	8.9	12.3
Total	6.6	15.4	32.3	51.9	69.6

Traffic in kilobits per second.

Traffic includes factor of 2 for peak to average.

Average message lengths by routing and by priority are given in Table 4. These averages were developed assuming message blocking such that message blocks do not exceed 400 characters in length.

As the traffic values presented here are projections, it is meaningful to consider the sensitivity of network costing to variations in projected traffic. A minimum traffic estimate has been derived from the best estimate projections presented in this section by considering factors that may reduce message lengths while maintaining predicted volume. Details of best estimate and minimum estimate derivations are presented in Appendix A, along with data on message length distributions by message category.

The effect of minimum traffic on network costing is discussed in Section VI.

D. REDUNDANCY

Redundancy is provided for any network segments in which a failure would disconnect more than one system termination. Redundancy is provided for the NCIC interface because outage would prevent access to the NCIC data base, which is the major data interface.

Line redundancy using backup dialup lines is used in options 1, 2, and 3 in connection with lines that are multiplexed in those options.

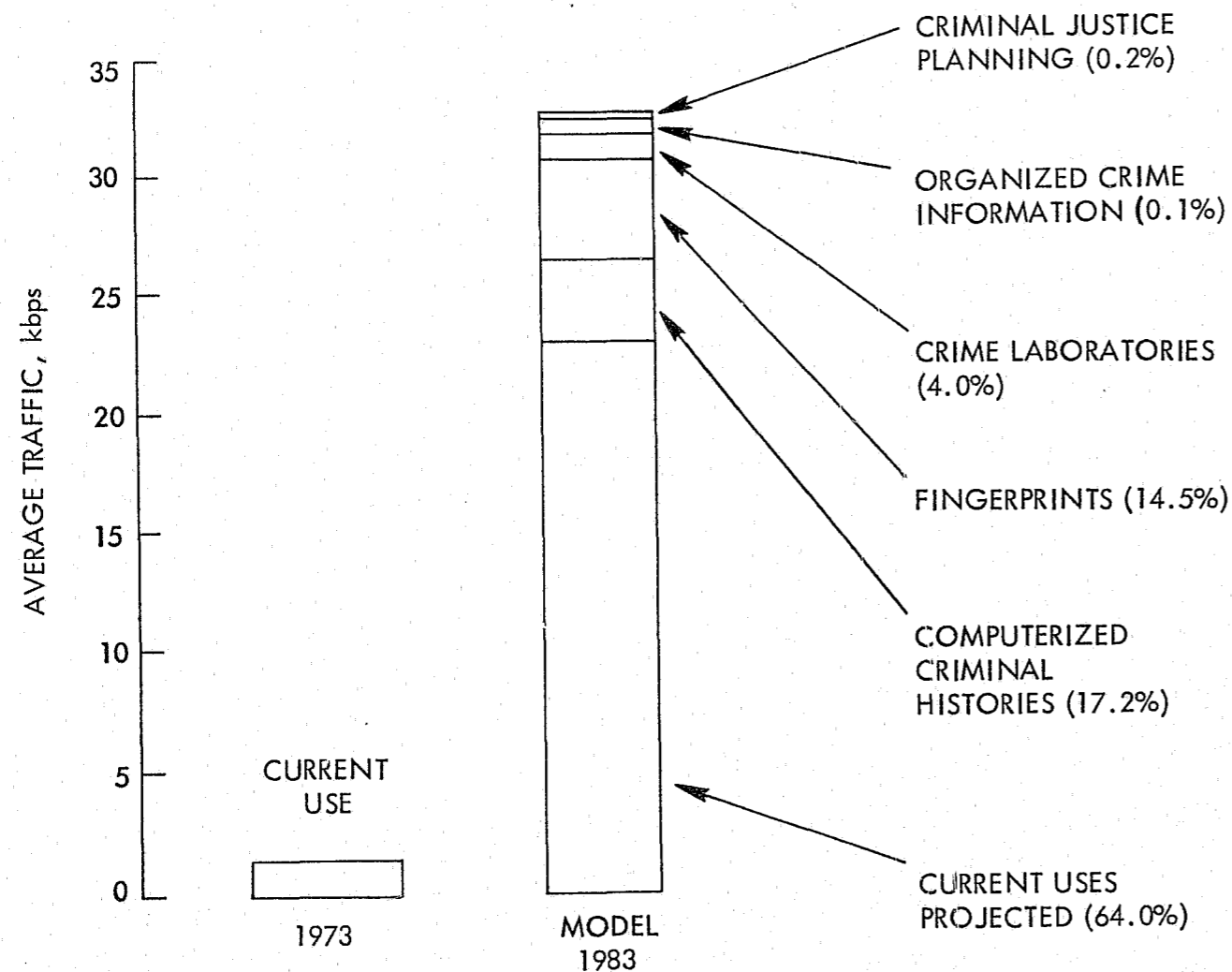

Fig. 1. NALECOM traffic summary

Table 2. State-national traffic projections (best estimate)

Item	1975		1977		1979		1981		1983	
	Mpy ^a	Kbps ^b	Mpy ^a	Kbps ^b	Mpy ^a	Kbps ^b	Mpy ^a	Kbps ^b	Mpy ^a	Kbps ^b
Current uses projected										
State-national	59.3	0.755	109.0	1.389	215.9	2.751	358.8	4.571	520.6	6.612
National-state	59.3	1.284	109.0	2.361	215.9	4.676	358.8	7.772	520.6	11.240
Computerized criminal history										
State-national	--	--	10.4	0.329	23.1	0.736	24.9	0.791	26.6	0.846
National-state	--	--	7.3	1.725	16.3	3.855	17.5	4.146	18.7	4.434
Fingerprints										
State-national	--	--	--	--	0.4	0.553	2.3	3.510	3.0	4.664
National-state	--	--	--	--	(Small)	(Small)	(Small)	(Small)	(Small)	(Small)
Criminal justice planners										
State-national	0.1	0.002	0.2	0.002	0.2	0.003	0.2	0.003	0.3	0.004
National-state	0.1	0.028	0.2	0.033	0.2	0.040	0.2	0.049	0.3	0.059
Criminal intelligence information										
State-national	(Small)	(Small)	(Small)	(Small)	(Small)	(Small)	(Small)	(Small)	(Small)	(Small)
National-state	(Small)	(Small)	(Small)	(Small)	(Small)	(Small)	(Small)	(Small)	0.2	0.010
Crime labs										
State-national	0.2	0.219	0.2	0.237	0.2	0.256	0.2	0.277	0.2	0.299
National-state	0.4	0.305	0.4	0.330	0.4	0.356	0.5	0.384	0.5	0.415
Total state-national	59.6	0.976	119.8	1.957	239.8	4.299	386.4	9.152	550.7	12.425
Total national-state	59.8	1.617	116.9	4.449	232.8	8.927	377.0	12.351	540.3	16.158

^aMillion messages per year.

^bKilobits per second.

All regional switching computers and regional switcher interfaces are redundant. All NALECOM switchers (either state or regional) are connected to other switchers through at least two paths; i. e., they are double-connected.

E. MULTIPLEXING

Time-division multiplexing is incorporated in options 1, 2, and 3 where it was found to be cost effective. Multiplexing techniques are most advantageous when a relatively close cluster of system terminations is to be served by a relatively distant regional switcher. The cost of separate lines to each system termination from the regional switcher is offset by running a single high-speed line to the vicinity of the system termination cluster and then multiplexing to each system termination from that point. Meaningful cost reductions realized in options 1, 2, and 3 are tabulated in Section V. Details of multiplex costing are given in Appendix B.

Table 3. State-state traffic projections (best estimate)

Item	1975		1977		1979		1981		1983	
	Mpy ^a	Kbps ^b	Mpy ^a	Kbps ^b	Mpy ^a	Kbps ^b	Mpy ^a	Kbps ^b	Mpy ^a	Kbps ^b
Current uses projected	9.6	0.694	17.7	1.208	35.0	2.264	57.9	3.646	84.3	5.240
Computerized criminal history	0	0	1.5	0.110	3.3	0.244	3.9	0.289	4.2	0.309
Crime labs	0	0	0	0	(Small)	0.436	(Small)	0.515	(Small)	0.595
Total	9.6	0.694	19.2	1.318	38.3	2.944	61.8	4.450	88.5	6.144

^aMillion messages per year.

^bKilobits per second.

Table 4. Average message lengths (1983 traffic)

		Fraction of messages	Average characters per message
By routing	S-N	0.471	82
	N-S	0.455	109
	S-S	0.074	278
By priority	1	0.791	90
	2	0.161	171
	3	0.048	396

F. LINE PROTOCOL

Protocols discussed in 1 and 2 below are used exclusively in the networks considered.

1. Half Duplex

The standard interface to all system terminations is half-duplex IBM binary synchronous communications (BSC), as described in document GA27-3004-2.

This protocol, which is referred to in this document as the National Law Enforcement Telecommunications System (NLETS) half-duplex protocol, was used in the network designs at the request of the Law Enforcement Assistance Administration (LEAA) to maintain consistency with existing networks.

In the NLETS protocol, the regional switcher behaves as a master in that it outputs all messages destined for a specific system termination before allowing any message inputs from that system termination. Three priorities are used, but all priority messages to be output from the switcher have priority over messages generated at system terminations.

All message transmissions are self-contained in that they are initiated by a request for the line (ENQ) and terminated by an end of transmission (EOT). When simultaneous line contention takes place, the switcher (or master) takes control of the line. This is basically the same protocol currently used by the NCIC and NLETS except that the three priority levels are presently in use.

2. Full Duplex

Full-duplex line discipline is used inter-regionally. In option 2, where a single regional switcher is located at Phoenix, full-duplex lines are used for communications between Phoenix and the NCIC in order to reduce line costs. A full-duplex to half-duplex converter is provided at the NCIC in option 2 so that the use of full-duplex protocol is not visible to the NCIC.

SECTION III NETWORK TOPOLOGY

Network topologies for the nine options covered in this document were selected with the aid of a network topology computer program developed at JPL for synthesis and analysis of NALECOM options.

The topology computer program constructs optimized (minimum line cost) network topologies that meet NALECOM requirements and constraints from input traffic data describing traffic requirements to and from each of the system terminations. The program performs the following four basic functions:

- 1) Divides the United States into the desired number of regions on the basis of equal traffic for each region.
- 2) Selects regional switcher locations for each region by searching for the system termination with the least message moment, $\Sigma(\text{traffic} \times \text{distance})$. That is, the switcher is located at the system termination that minimizes the total message miles within each region.
- 3) Selects intra-region and inter-region line capacities as a function of traffic.
- 4) Optimizes inter-region line topology on a minimum cost basis.

In certain cases, switcher locations are predetermined. Manual adjustments of regional boundaries are also often made to achieve contiguous regional structures and to minimize overall costs.

A. SELECTION OF REGIONS

Before any communication line assignments can be considered, the regional configuration must first be established. States can be preassigned to regions by the program user or assignments derived by the topology program itself.

The program derives regions by first selecting the farthest system termination point from a specified national communication centroid. The input and output traffic of the selected state is summed. If the sum does not exceed the total network traffic divided by the number of regions in that particular program run, then the system termination closest to the first termination is added to the region. The total traffic from both states is then summed and tested again against the total traffic allocated for each region. The program continues to add states to the region until the regional traffic requirement is met. Figure 2 shows this process. The process is then repeated for the next region until all states are assigned to regions.

Slight adjustments were manually made to regional boundaries before final program runs in order to obtain contiguous, minimum cost regional structures.

B. INTRA-REGION LINE SELECTION

Regions are generally configured internally as star networks in which each system termination in the region has one or more direct half-duplex links with the regional central switcher. Figure 3 shows a star network for a region covering the western United States.

The networks use intra-region communication lines of 2400, 4800, 7200, and 9600 bps, or combinations of these line capacities. A single 2400-bps line is the minimum line service used to meet network delay requirements.

Queueing analysis indicates that the system can deliver messages in a timely manner if the line utilization does not exceed 0.7. The line utilization, or ρ (rho), is defined as the ratio of the total time a line is actually in use to the total time period considered. For each system termination in a region, rho is calculated as a function of message service time and traffic, and the least expensive combination of lines is assigned that maintains line utilization rates less than 0.7. For intra-region half-duplex lines, rho is calculated in the following manner:

$$\rho = \left(\frac{T}{L_m \times B_c} \right) \left[\frac{(L_m + OH)B_c}{C} + NTA \times D \times DDL + NPT \right]$$

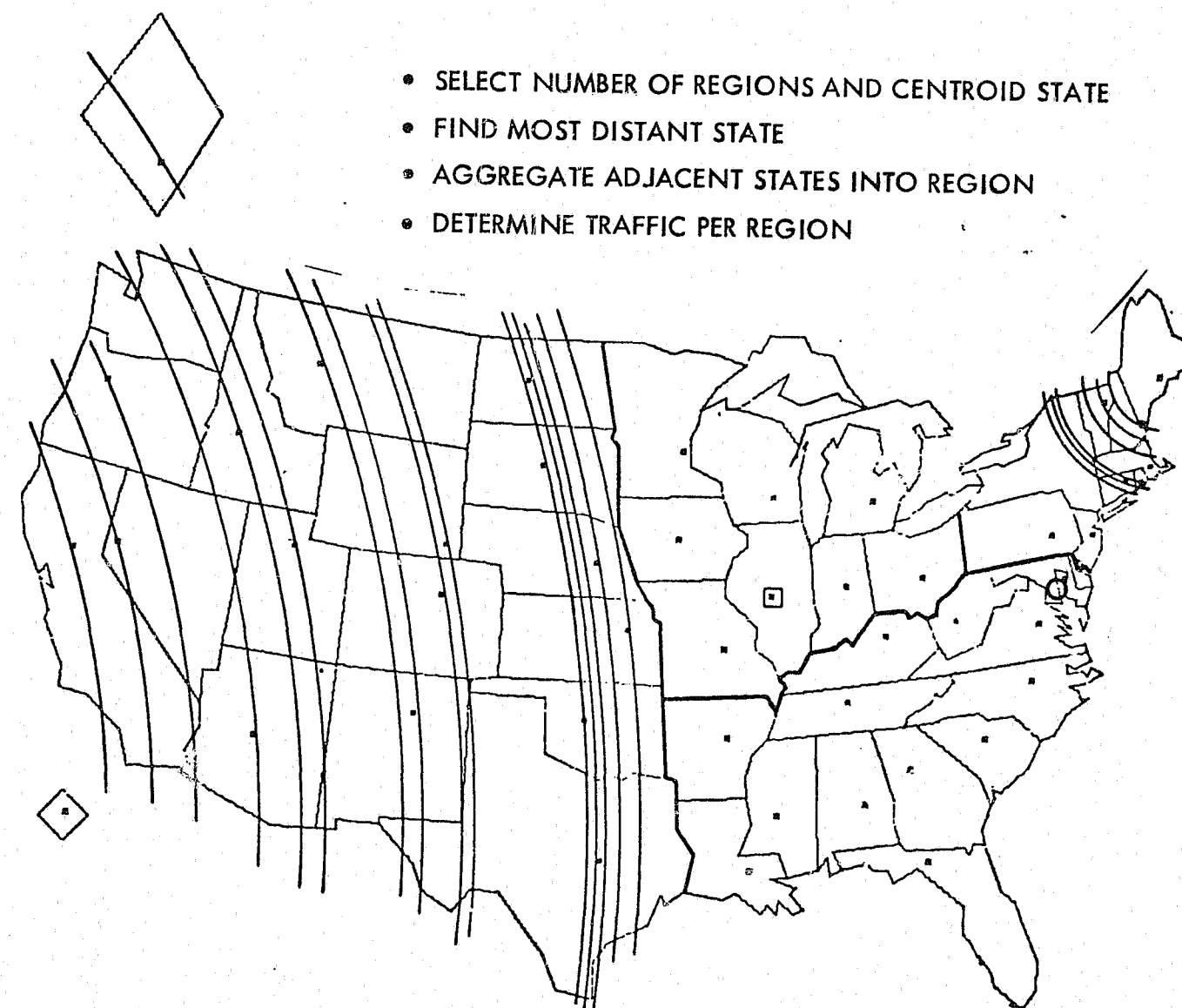

Fig. 2. Network optimization: selection of regions

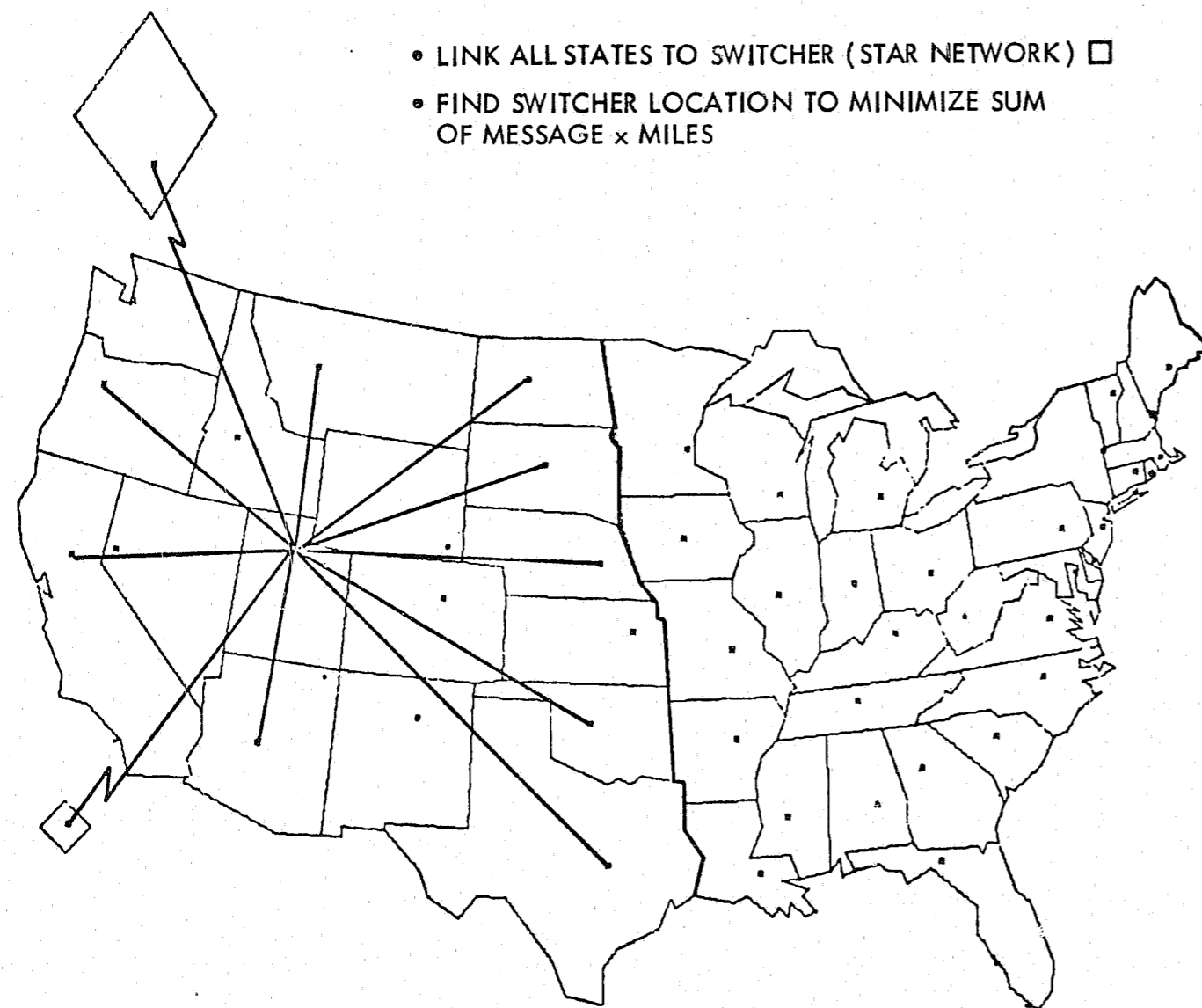

Fig. 3. Network optimization: location of regional switcher

where

T = traffic, bps

L_m = average message length in characters

B_c = bits/character = 8

OH = overhead characters or message characters other than actual text characters

C = line capacity, bps

NTA = average number of line turnarounds required to complete a message

D = distance from system termination to regional switcher, mi

DDL = line propagation delay, ms/100 mi

NTP = nodal processing time

The term in brackets is the service time, T_s ; the term in parentheses is often referred to as n , the number of messages/second. Thus, ρ is often written as:

$$\rho = nT_s$$

For a given link between a system termination and a regional switcher, the traffic (T) and the distance (D) are given and successive values of C are attempted until ρ is less than 0.7. A sample calculation is provided in Appendix B along with line cost details.

C. INTER-REGION LINE SELECTION

Inter-region lines provide communication paths between the regional switchers. Initially each switcher is interconnected with all other regional switchers. The network uses inter-region lines of 4800, 7200, 9600, or 50,000 bps, or combinations of these capacities. A minimum of 4800-bps service is used inter-regionally in order to meet network delay goals.

As inter-region lines are full duplex, a simpler rho calculation is permitted as follows:

$$\rho = \frac{T_h}{C}$$

where

T_h = maximum traffic flowing in either direction on the full-duplex link

C = line capacity, bps

In the inter-region calculations, rho is required to be less than 0.5. With the estimated full-duplex overhead, the final ρ will be less than 0.7.

When the basic inter-region line selections have been made, an inter-region line optimization procedure is then executed as outlined below.

D. INTER-REGION LINE OPTIMIZATION

The initial inter-region line selection is optimized in multiple-region cases by eliminating lines that lead to cost savings and still meet traffic requirements. Figure 4 illustrates the optimization procedure for a five-region configuration. The program eliminates lines one by one and diverts traffic over remaining links. The algorithm first tries to divert traffic to lines with excess capacities and then, if it must, adds capacity to alternate routes. In the final optimization, at least two lines must be connected to each switcher. Paths between switchers are not allowed to pass through more than one intermediate switcher. These criteria ensure that alternate paths are provided in multi-regional cases in such a manner that message delay goals are met.

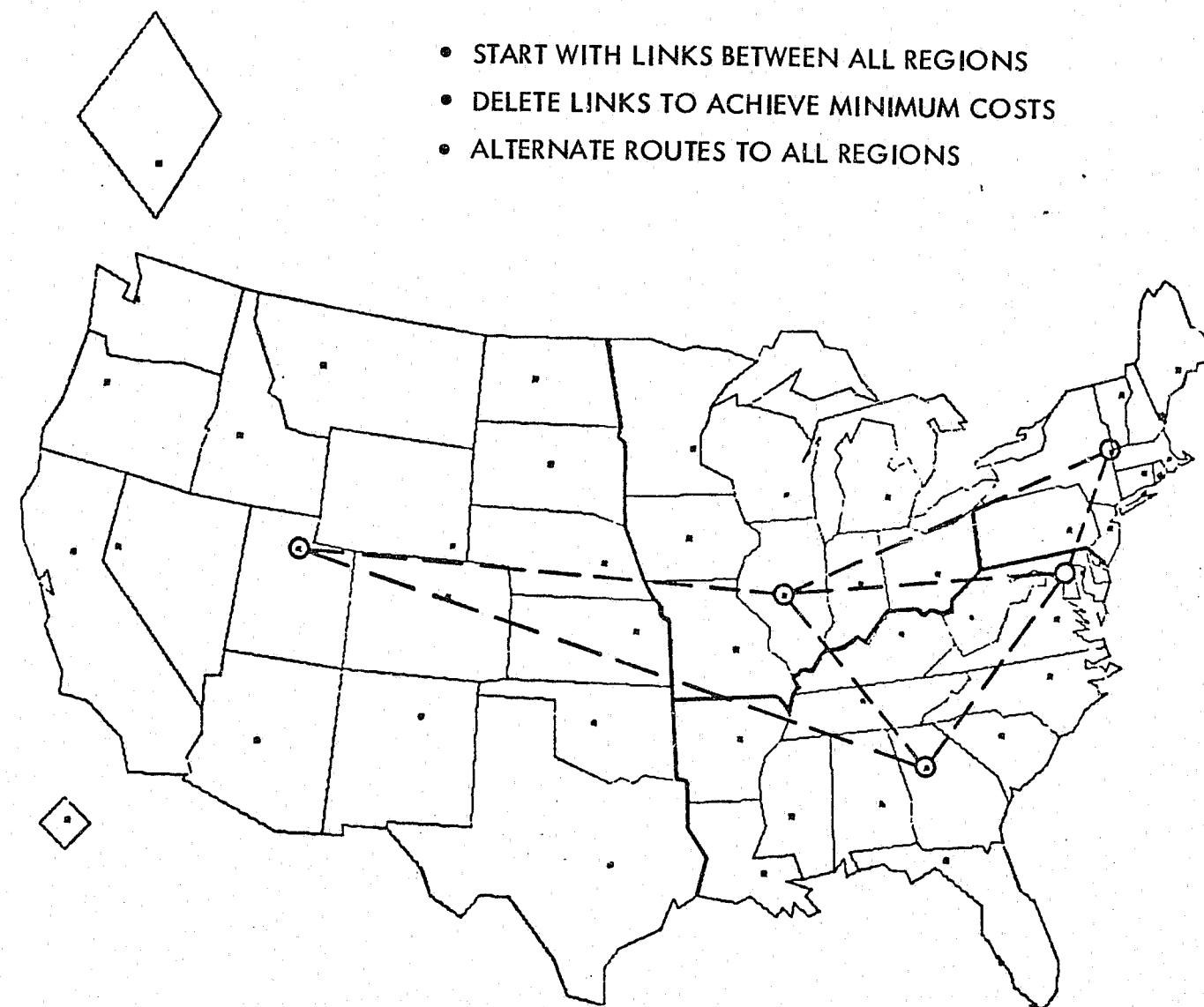

Fig. 4. Network optimization: inter-region network selection

SECTION IV EVALUATION CRITERIA

In the analysis of alternative system approaches, it is important to provide quantitative measures to all factors that impact the decision process. Dollar costs are easiest to quantify. There are other criteria, however, that are at least as important and, in some cases, more so. This section discusses the approach to network costing and quantitative measurement of other evaluation criteria.

A. COST

Detailed cost evaluations for each option are presented in Section V. Details are divided into one-time costs, recurring costs, personnel costs, and engineering costs. Table 5 gives the cost items for entries tabulated under cost details in Section V.

In addition to the costs given in Table 5, engineering costs are also tabulated. A 2-year lead time is allocated between the beginning of engineering effort and of network operation. In general, engineering costs taper to zero in the second year of network operation. Option 7, which involves four phases of implementation, is an exception.

The cost detail sheets for each option presented in Section V assume engineering design activity starts in January 1975. One-time installation costs are primarily evidenced in 1976, the year before the beginning of network operation. As a rule, network upgrading takes place in 1979 in preparation for the first year of upgraded operation in 1980. This upgrade schedule reflects additional one-time cost entries in 1979 and an increment in recurring costs for lines and switchers in 1980. A deviation from this general rule occurs in option 7 where upgrading to the final stage of satellite capability takes place in three stages.

Cost detail backup data are provided in Appendix I where costs for each of the above categories are further divided for each option.

Cost estimates for option 7 are estimated to be accurate to $\pm 20\%$. Accuracy for all other options is estimated as $\pm 10\%$.

Table 5. Cost items

Cost terms	Cost items included
One time	
Lines	Installation costs for lines, modems, and service terminals
Hardware	Installation costs for basic switching computers, peripheral equipment, computer line interfaces, full-duplex converters, microwave installations, and satellite ground stations where applicable
Computer software	One-time cost of a single software package which is duplicated and used at each switcher
Facilities	One-time facility preparation costs
Recurring	
Lines	Maintenance costs for communications lines, modems, and service terminals. Space link lease costs are also included in this category in option 7
Hardware	Maintenance costs for basic computers, computer line interfaces, computer peripherals, and microwave and ground stations where applicable.
Facilities	Rental costs for floor space and utilities at regional switcher sites plus backup power supply maintenance
Operations	
Operating personnel	Salaries for supervisory, programming, and computer-operating personnel plus travel costs

B. TECHNICAL CRITERIA

1. Response Times

Response-time goals for the NALECOM Network outlined in Section II-A-6 were derived from requirements for Police Information System response times given in Ref. 7.

For each of the nine NALECOM options, delay calculations were conducted for the worst possible link configuration in terms of average delay interconnecting one system termination with another. Conditions for the calculations were that: (1) interfaces to system terminations use communication lines with capacity equal to or greater than 2400 bps, (2) inter-region lines have capacities equal to or greater than 4800 bps, and (3) line utilization (the fraction of time a line is in use over a given period of time) does not exceed 0.7.

Details of response-time, or network delay time, calculations are presented in Appendix G.

2. Reliability

A reliability analysis was conducted for each of the nine network configurations. The goal of the analysis was to determine the average fraction of time that the worst-case network routing could be expected to be operational. This fraction of time is referred to as network availability.

The goal for availability for each network option is 0.993, which is equivalent to an outage of less than 10 min/day. An outage is defined as a complete disconnect between two network nodes.

Compliance with availability goals is developed by using redundancy at network locations where an outage would cause more than one system termination to be disconnected by providing double connectivity at switchers, and providing backup power supplies to commercial power at switchers.

A detailed description of techniques for developing availability figures for serial and parallel paths together with component availability estimates are presented in Appendix H.

3. Subjective Technical Evaluation Criteria

In addition to response time and reliability, other technical evaluation criteria were identified and analyzed. For each of the criteria, relative numerical weightings were assigned for each of the options under consideration.

This group of evaluation criteria is technical in nature and consists of the following points:

- (a) Flexibility.
- (b) Ease of implementation.
- (c) Simplicity
- (d) Privacy.
- (e) Security.

For each of these criteria, the impact of specific factors was evaluated for each option. Table 6 is the evaluation form which lists the specific points evaluated for each criteria.

The evaluation forms were given to four senior JPL engineers on the NALECOM Project. One input was received by LEAA and reviewed. The LEAA input did not alter any relative rankings and was not included in the final evaluation.

In all cases, each respondent was asked to work independently in assigning ratings to each entry in the form; a rating of 1 meant poor, 2 fair, 3 average, 4 good, and 5 meant excellent.

If a respondent entered a rating of 1 (poor) or 5 (excellent), he was asked to indicate on a separate sheet how the conclusion was reached. He was also instructed to leave blank all entries on which he did not feel competent to comment. Ratings from respondents were averaged and converted to a scale of 0 to 100, where 100 is an excellent rating.

Results of the evaluation criteria analysis are presented in Section VI. An evaluation form showing detailed averages from respondents is presented in Appendix J.

Table 6. Evaluation form

	Option								
	1	2	3	4	5	6	7	8	9
	N-DC S-PH	1 REG PH	1 REG DC	2 REG PH-DC	5 REG	50 REG	2 REG W/VIDEO	10 REG	25 REG
I. Ease of Implementation									
a) Switchover to new network from existing capability									
b) Minimum of technical design risks									
c) Number of switchers									
d) Number of lines									
Subtotal									
II. Simplicity									
a) Design									
b) Control operations									
c) Maintenance									
d) Upgrades									
e) Routing									
f) User interface									
g) Network checkout									
h) Monitoring network (statistics gathering)									
Subtotal									
III. Privacy									
a) Must data other than header (routing data msg type) and msg lengths be stored									
b) Difficulty in accommodating new legislation changes									
Subtotal									
IV. Flexibility									
a) Can new system terminations be easily added?									
b) Can network be expanded to handle traffic 2 x predictions?									
c) Expansion for 4 x predictions									

Table 6. (Contd)

	Option								
	1	2	3	4	5	6	7	8	9
	N-DC S-PH	1 REG PH	1 REG DC	2 REG PH-DC	5 REG	50 REG	2 REG W/VIDEO	10 REG	25 REG
IV. Flexibility (contd)									
d) Design flexibility during implementation phase?									
e) Can audit or format checks be added easily?									
f) Can system termination connections to network be changed easily to balance switcher/line loading?									
Subtotal									
V. Security									
a) Message intercept protection									
b) Message insertion protection									
c) Facility physical security against acts of violence									
d) Comm line physical security									
e) Dedication to criminal justice use									
f) Physical security against unwanted personnel having access to switchers									
g) Cost of security personnel if required									
h) Is present NCIC data base security maintainable?									
i) Can an act of physical violence severely degrade the network?									
Subtotal									
Totals									
Averages									

C. NON-TECHNICAL CRITERIA

Non-technical criteria are not included in the network evaluation. However, it should be recognized that non-technical criteria may be a major factor in network selection or in breaking a tie between two networks of near equal ranking. Such criteria include network acceptability and ease of selection of network management. Ease of selection of network management is a self-contained item; however, a number of points should be considered as pertinent to network acceptability. These points consider whether the network to be accepted:

- 1) Retains existing capabilities.
- 2) Allows states to upgrade as desired.
- 3) Is a large change from present network operations.
- 4) Is acceptable to existing managements.

In order to evaluate these criteria, a survey of network users and existing network managers should be made.

SECTION V
DETAILS OF EACH OPTION

This section contains a detailed description of each of the nine options considered. For each option a general description is provided along with a discussion of topology, constraints, and option costs. Further detail cost back-up is presented in Appendix I.

1. Option 1

a. Description.

General description. Option 1 consists of two separate networks, one handling state-to-state traffic through a switcher in Phoenix and a second handling state-to-national traffic to the NCIC data base through a computer in Washington, D. C. The primary intent of this option is to determine whether operation of two separate networks leads to major cost differentials as compared with the use of one network handling the total traffic.

Topology. The basic option 1 approach consists of the superposition of two star networks, one centered in Phoenix and one in Washington, D. C., each with one or more lines connected to each system termination. This type of configuration is amenable to the use of multiplexing techniques which were applied to reduce line costs. Figure 5 shows the state-to-state network with multiplexing sites; Fig. 6 shows the state-to-national network with multiplexing sites.

Figure 7 shows the two networks superimposed to form the option 1 configuration. Multiple pathways to single system terminations do not represent alternative pathways for message flow because the networks are discrete functional entities. The figure shows the redundant use of communications lines in option 1 due to the duplication of lines at each system termination.

Constraints. For option 1, the topology program was run separately for the state-to-state and state-to-national networks. For the state-to-state network, Phoenix was pre-loaded as the switcher location to conform to the NLETS facility location.

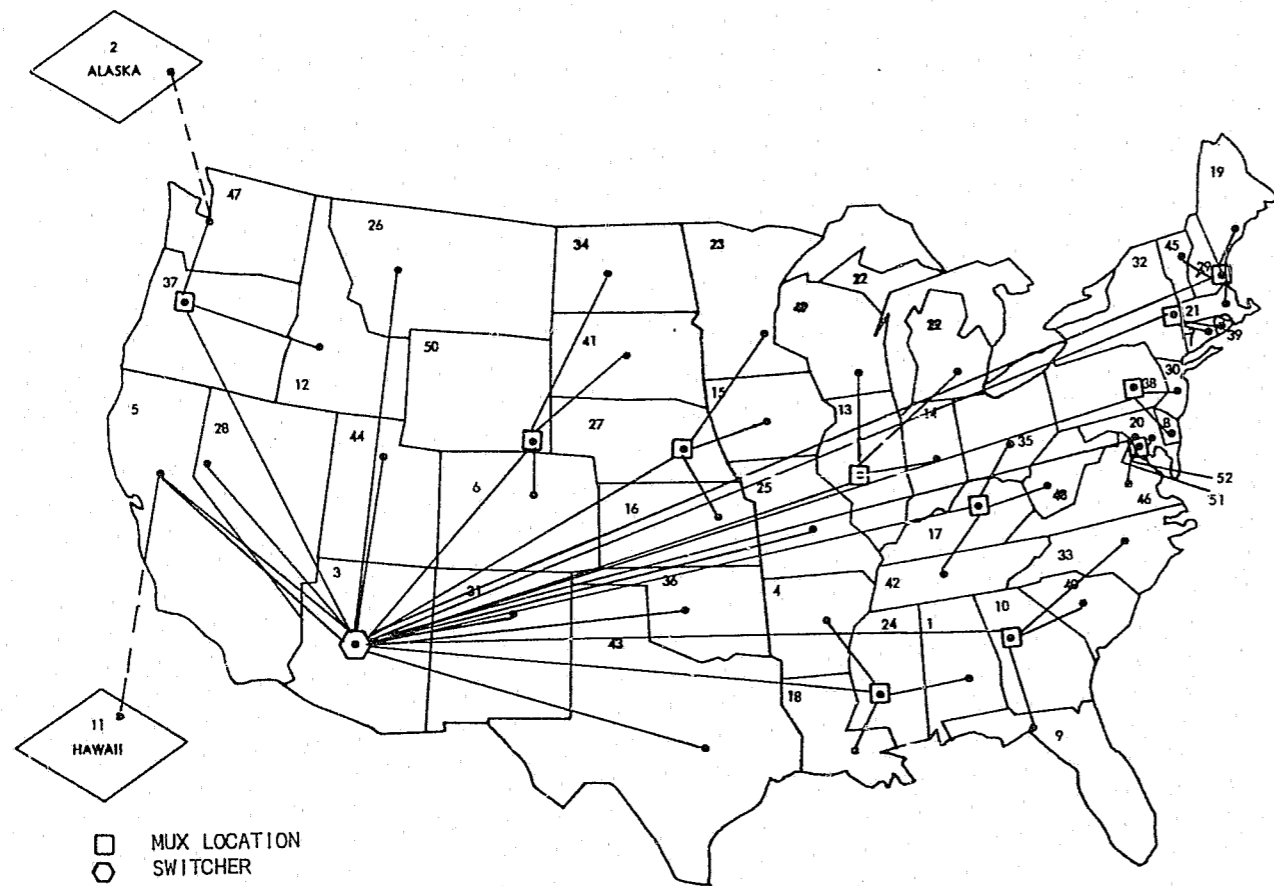

Fig. 5. Option 1. State-to-state network configuration: 1979-1983

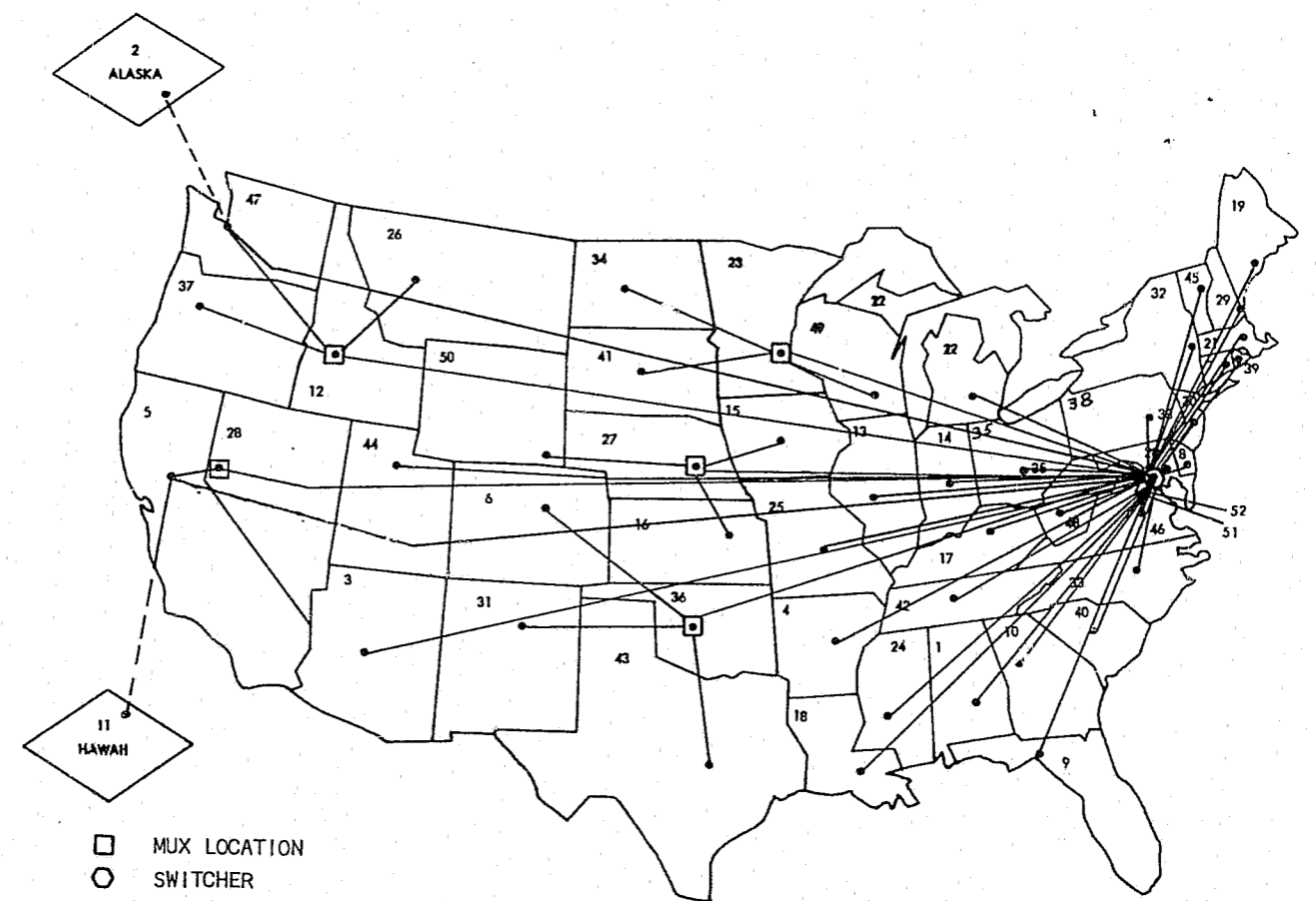

Fig. 6. Option 1. State-to-national network MUX configuration: 1980-1983

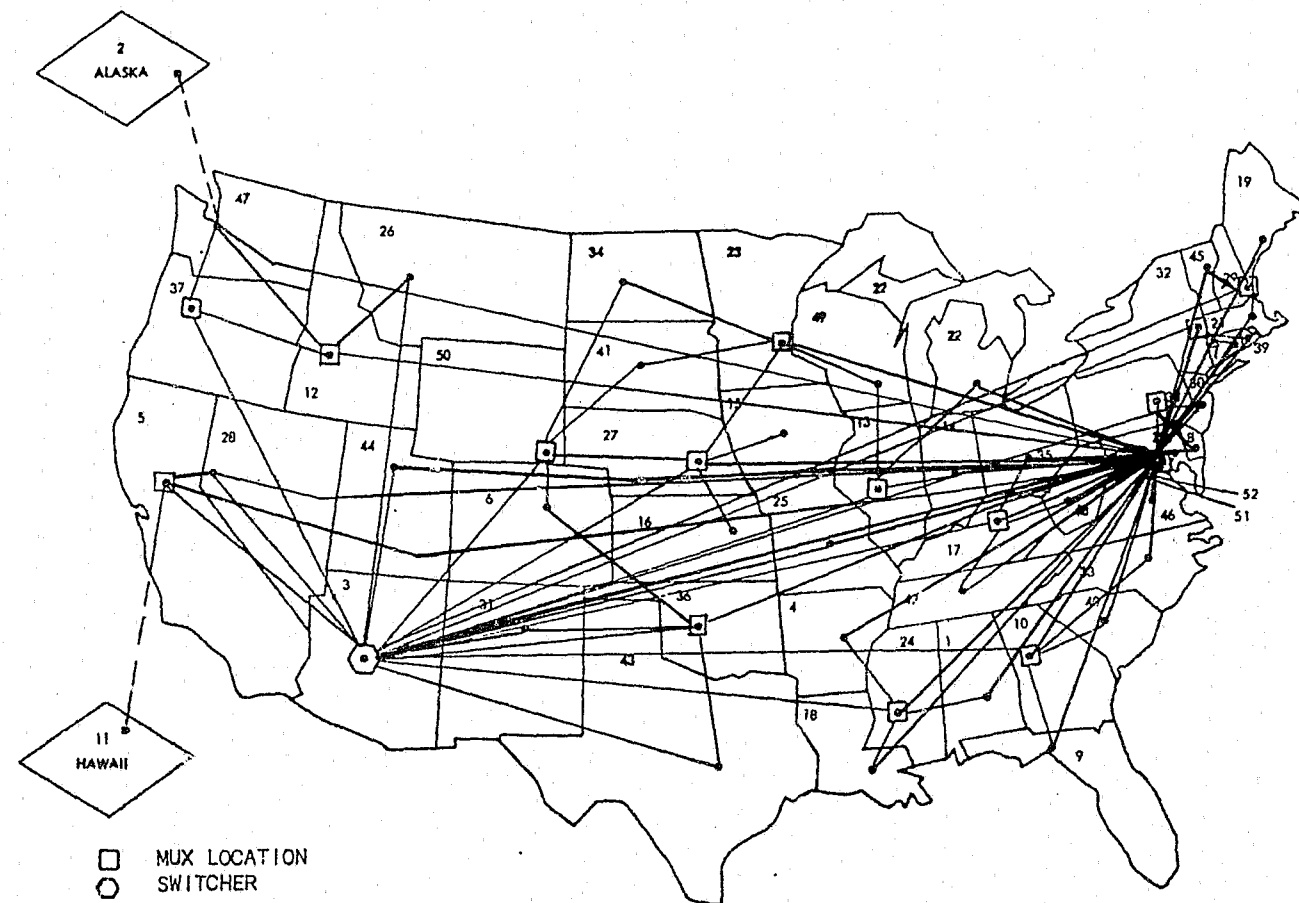

Fig. 7. Option 1. Overlay of separate state and national network configurations: 1979-1983

Traffic projections call for the NLETS facility to be upgraded in 1977, with the upgrade operational in 1978. The present NLETS computer will be used throughout 1976 and 1977. A line printer is scheduled to be installed in 1977. Existing NLETS computer software will receive a minor upgrade in 1977.

Computer interfaces will be added to existing interfaces at Phoenix to meet upgrade requirements; however, as in all cases, they will be installed in 1976. A backup power supply is also included at Phoenix to be consistent with the other options.

For the state-to-national network, Washington, D.C. was preloaded as the switcher site. The D.C. configuration in option 1 is structured as a completely new installation.

Multiplexing is incorporated in both networks. Multiplexing sites are connected to switchers through 9600- or 4800-bps lines; they service up to four system terminations in accordance with multiplexing rules outlined in Appendix B. Eleven multiplexing sites are implemented in the state-to-state network and five in the state-to-national network as shown in the topology figures.

b. Cost. Figure 8 summarizes cost details for option 1 with multiplexing. The total cost is \$12,220,000. An upgrade to the existing Phoenix system takes place in 1977 to meet operational requirements for that facility in 1978. This upgrade is shown in one-time cost entries in 1977 and an increment in recurring costs in 1978. The normal network upgrade that applies to all options, except option 7, takes place in 1979 and results in a further increment in recurring costs in 1980.

Figure 9 shows cost details for option 1 without multiplexing. The total cost is \$13,439,000, indicating a savings of \$1,219,000 in this option due to multiplexing. The lower cost figure for option 1 with multiplexing is used in the final network comparison matrix in Section VI.

OPTION: 1
 REMARKS: SEPARATE STATE AND NATIONAL NETWORKS, WITH MULTIPLEXING

ITEM	CALENDAR YEAR									TOTAL
	1975	1976	1977	1978	1979	1980	1981	1982	1983	
I. ONE-TIME COSTS										
1. LINES		27	1	-	15	-	-	-	-	43
2. COMPUTER HARDWARE		821	113	-	-	-	-	-	-	934
3. COMPUTER SOFTWARE		294	30	-	-	-	-	-	-	324
4. FACILITIES		100	-	-	-	-	-	-	-	100
II. RECURRING COSTS										
1. LINES			1045	1053	1053	1173	1173	1173	1173	7843
2. SWITCHERS			119	126	126	141	141	141	141	935
3. FACILITIES			22	22	22	22	22	22	22	154
III. OPERATING PERSONNEL			154	154	154	154	154	154	154	1078
IV. ENGINEERING	257	368	169	15						809
ANNUAL SUBTOTALS	257	1610	1653	1370	1370	1490	1490	1490	1490	

OVERALL TOTAL 12,220

Fig. 8. Cost details

OPTION: 1
 REMARKS: SEPARATE STATE AND NATIONAL NETWORKS, WITHOUT MULTIPLEXING

ITEM	CALENDAR YEAR									TOTAL
	1975	1976	1977	1978	1979	1980	1981	1982	1983	
I. ONE-TIME COSTS										
1. LINES		27	1	-	15	-	-	-	-	43
2. COMPUTER HARDWARE		821	113	-	-	-	-	-	-	934
3. COMPUTER SOFTWARE		294	30	-	-	-	-	-	-	324
4. FACILITIES		100	-	-	-	-	-	-	-	100
II. RECURRING COSTS										
1. LINES			1234	1242	1242	1336	1336	1336	1336	9062
2. SWITCHERS			119	126	126	141	141	141	141	935
3. FACILITIES			22	22	22	22	22	22	22	154
III. OPERATING PERSONNEL			154	154	154	154	154	154	154	1078
IV. ENGINEERING	257	368	169	15						809
ANNUAL SUBTOTALS	257	1610	1842	1559	1559	1653	1653	1653	1653	

OVERALL TOTAL 13,439

Fig. 9. Cost details

2. Option 2

a. Description.

General description. This option is a single-switcher configuration, with the switcher located in Phoenix serving total state-to-state and state-to-national traffic. The primary intent of this option is to determine the cost of expanding the NLETS network such that it can handle the total traffic requirements.

Costs for this option were first derived using a new computer installation at Phoenix and then using existing NLETS hardware and software. Savings through the use of multiplexing were also found to be meaningful in this option.

Because of the great distance between Phoenix and the NCIC, half-duplex lines are replaced with full-duplex lines in each consideration of option 2 in order to reduce line costs.

Topology. Option 2 consists of a single star network centered in Phoenix with multiplexing employed where applicable. The network topology is shown in Fig. 10. From a communication line standpoint, this figure shows that Phoenix constitutes an inefficient single-switcher location due primarily to the large number of system terminations in the east with resultant excessive use of long communication lines.

Constraints. The topology program was run for option 2 with Phoenix specified as a single-switcher location. The topology program assigned 23 half-duplex lines between Phoenix and the NCIC. Option 2 line and computer interface savings were realized by replacing these half-duplex lines with three full-duplex lines. A full-duplex to half-duplex converter is installed at the NCIC so that the use of full-duplex lines is invisible to the NCIC. Half-duplex lines run the short distance between the half-duplex side of the converter and the actual NCIC site. The Phoenix computer is capable of handling full-duplex protocol.

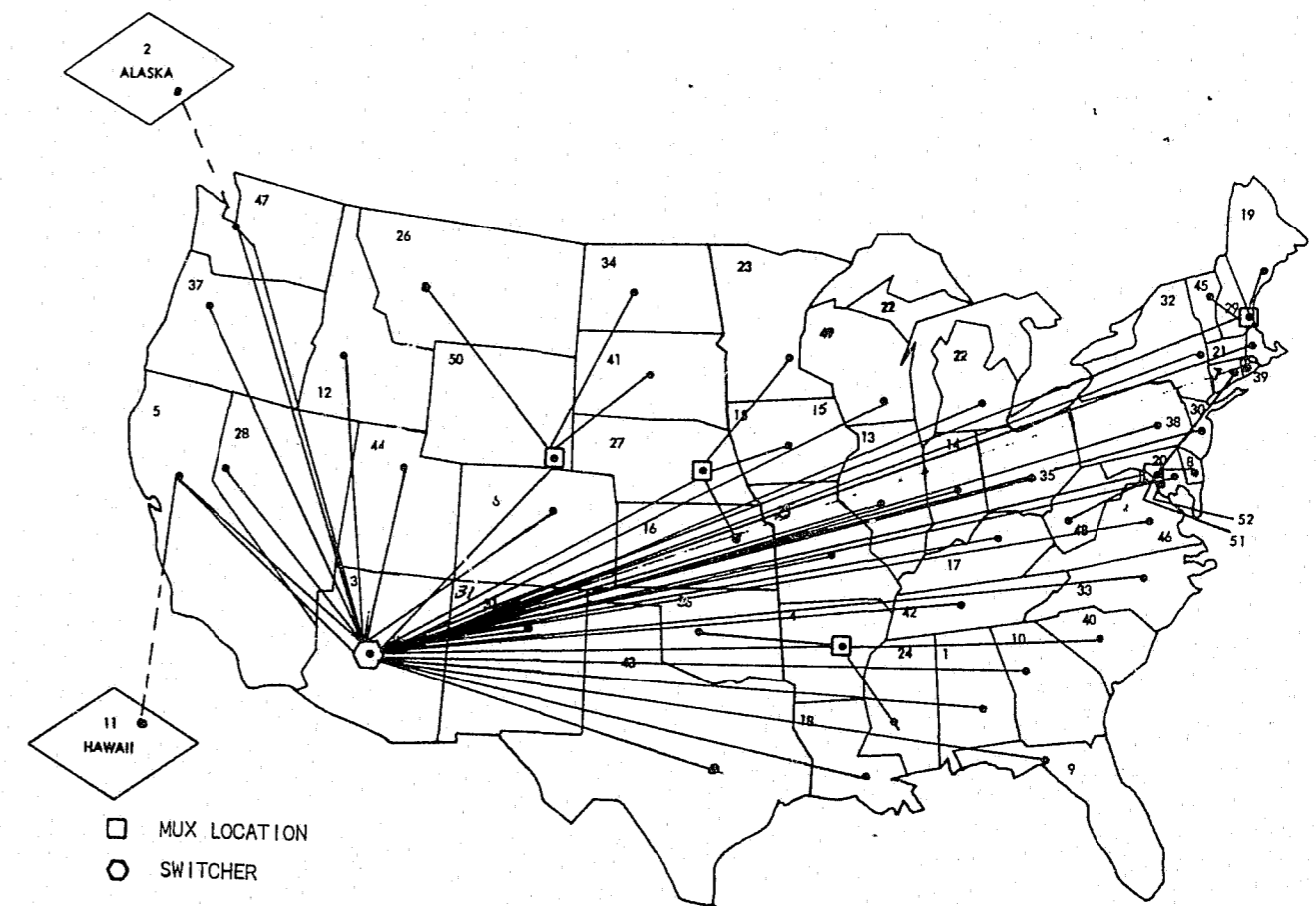

Fig. 10. Option 2. Network topology configuration: 1979-1983

In each of the option 2 cases, network operation will start in 1977; a single-line upgrade takes place in 1979 and will become operational in 1980.

Line costs are further reduced through the use of multiplexing. From 1977 through 1979, eight multiplexing sites will be used. After the upgrade, five multiplexing sites will operate from 1980 through 1983. Figure 10 shows the 1983 configuration.

b. Cost. Figure 11 shows cost details for option 2 with multiplexing, and a new computer installed in Phoenix. The total cost is \$10,031,000. Figure 12 shows details of costs realized when the existing NLETS computer is upgraded to meet NALECOM requirements. The total cost using the NLETS upgrade is \$9,870,000 for a savings of \$161,000 over the 7-year network life. The principal factors contributing to the cost difference are computer hardware and software one-time costs and switcher recurring costs.

The NLETS computer hardware one-time cost has software cost bundled with hardware costs, which accounts for the large value (\$1,124,000) of that entry. The \$40,000 one-time software entry is for the full-duplex to half-duplex converter software. This \$40,000 one-time software cost is also included in the \$334,000 entry seen in Fig. 11.

Recurring switcher costs are lower for the NLETS upgrade and are constant throughout the 7-year period. While basic computer costs for the upgrade are higher, the line interface costs are considerably lower, bringing the total recurring switcher costs for the upgrade case to \$101,000 per year as shown.

All other costs for the NLETS upgrade vs new computer comparison remain the same in each case.

Figure 13 shows option 2 costs without multiplexing. The cost detail sheet is made out for the new computer case and shows a total cost of \$10,472,000. Savings due to multiplexing alone in this option are \$441,000 over the 7-year network life. These savings are independent of whether the NLETS upgrade or new computer approach is implemented.

Cost savings due to the use of full-duplex lines to the NCIC, instead of half-duplex lines, amount to \$37,000 in installation costs and recurring savings of \$162,000 per year from 1976 to 1979 and \$334,141 per year from 1980 to 1983. These savings, although not shown explicitly in the cost detail figures, are considered in the final totals.

OPTION: 2
REMARKS: 1 SWITCHER PHOENIX, WITH MULTIPLEXING AND NEW COMPUTER

ITEM	CALENDAR YEAR									TOTAL
	1975	1976	1977	1978	1979	1980	1981	1982	1983	
I. ONE-TIME COSTS										
1. LINES		19	-	-	19	-	-	-	-	38
2. COMPUTER HARDWARE		871	-	-	-	-	-	-	-	871
3. COMPUTER SOFTWARE		334	-	-	-	-	-	-	-	334
4. FACILITIES		50	-	-	-	-	-	-	-	50
II. RECURRING COSTS										
1. LINES			708	708	708	962	962	962	962	5972
2. SWITCHERS			105	105	105	128	128	128	128	827
3. FACILITIES			11	11	11	11	11	11	11	77
III. OPERATING PERSONNEL			152	152	152	152	152	152	152	1064
IV. ENGINEERING	399	319	80							798
ANNUAL SUBTOTALS	399	1593	1056	976	995	1253	1253	1253	1253	
										OVERALL TOTAL 10,031

Fig. 11. Cost details

OPTION: 2
 REMARKS: 1 SWITCHER PHOENIX, WITH MULTIPLEXING AND NLETS UPGRADE

ITEM	CALENDAR YEAR									
	1975	1976	1977	1978	1979	1980	1981	1982	1983	TOTAL
I. ONE-TIME COSTS										
1. LINES		19	-	-	19	-	-	-	-	38
2. COMPUTER HARDWARE		1124	-	-	-	-	-	-	-	1124
3. COMPUTER SOFTWARE		40	-	-	-	-	-	-	-	40
4. FACILITIES		50	-	-	-	-	-	-	-	50
II. RECURRING COSTS										
1. LINES			708	708	708	962	962	962	962	5972
2. SWITCHERS			101	101	101	101	101	101	101	707
3. FACILITIES			11	11	11	11	11	11	11	77
III. OPERATING PERSONNEL			152	152	152	152	152	152	152	1064
IV. ENGINEERING	399	319	80							798
ANNUAL SUBTOTALS	399	1552	1052	972	991	1226	1226	1226	1226	

OVERALL TOTAL **9,870**

Fig. 12. Cost details

OPTION: 2
 REMARKS: 1 SWITCHER PHOENIX, WITHOUT MULTIPLEXING, WITH NEW COMPUTER

ITEM	CALENDAR YEAR									
	1975	1976	1977	1978	1979	1980	1981	1982	1983	TOTAL
I. ONE-TIME COSTS										
1. LINES		19	-	-	19	-	-	-	-	38
2. COMPUTER HARDWARE		871	-	-	-	-	-	-	-	871
3. COMPUTER SOFTWARE		334	-	-	-	-	-	-	-	334
4. FACILITIES		50	-	-	-	-	-	-	-	50
II. RECURRING COSTS										
1. LINES			787	787	787	1013	1013	1013	1013	6413
2. SWITCHERS			105	105	105	128	128	128	128	827
3. FACILITIES			11	11	11	11	11	11	11	77
III. OPERATING PERSONNEL			152	152	152	152	152	152	152	1064
IV. ENGINEERING	399	319	80							798
ANNUAL SUBTOTALS	399	1593	1135	1055	1074	1304	1304	1304	1304	

OVERALL TOTAL **10,472**

Fig. 13. Cost details

3. Option 3

a. Description.

General description. This network contains a single switcher located in Washington, D. C. and is configured to serve total state-to-state and state-to-national traffic. Consideration of this option was specifically requested by LEAA. However, it is also the optimum configuration for a single-switcher network handling the total NALECOM traffic requirements with the NCIC located in Washington, D. C.

Costs were derived using a new computer installation at Washington, D. C. capable of handling total NALECOM traffic requirements and upgrades.

Multiplexing to various distant western states was incorporated to reduce communication line costs.

A minimum traffic analysis was also conducted for the option 3 configuration. The minimum traffic analysis consists of generating complete cost details based on traffic estimates considered to be at a minimum. The purpose of the exercise is to gain understanding regarding the sensitivity of total costs to variations in estimated traffic levels. A minimum traffic analysis is also conducted in option 4, the two-region case. Results of the minimum traffic analysis are presented in Section VI.

Topology. Option 3 consists of a single star network centered in Washington, D. C., with multiplexing employed where applicable. The network topology is shown in Fig. 14.

Washington, D. C. represents the most cost-effective single-switcher location. This is primarily due to the higher volume of state-to-national traffic over state-to-state traffic, and the large number of states in the East (reducing total line distances).

Constraints. The topology program was run for option 3 with Washington, D. C. specified as a single-switcher location. Single-switcher locations were also considered in Indiana, Illinois, and Ohio with full-duplex lines to the NCIC. These locations showed cost increases and were not considered further.

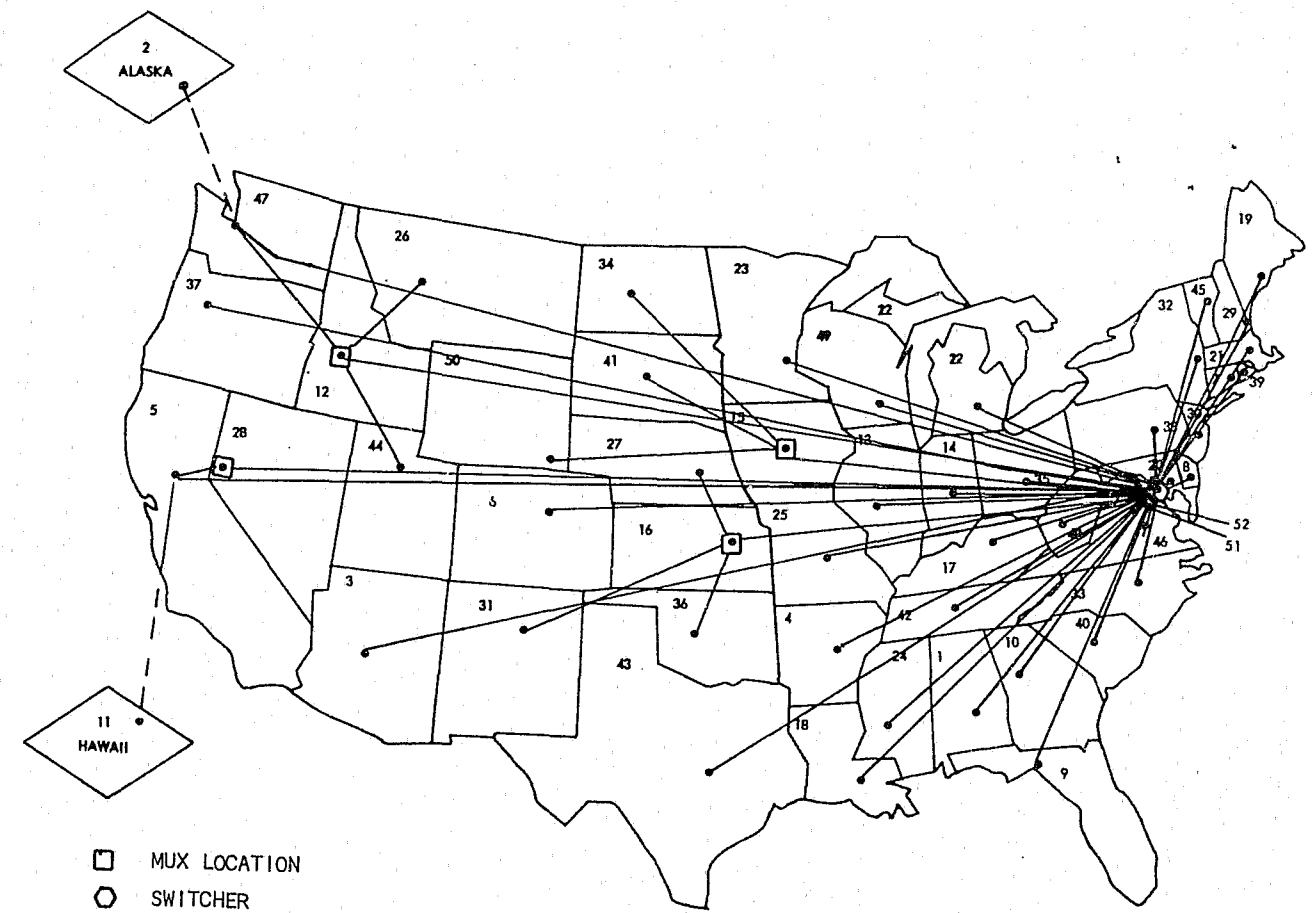

Fig. 14. Option 3. Network topology configuration: 1979-1983

Multiplexing to western states is used to advantage in option 3. From 1977 through 1979 five multiplexing sites are used; from 1980 through 1983 four multiplexing sites are used. Figure 14 shows the four 1983 multiplexing sites.

b. Cost. Figure 15 shows cost details for option 3 with multiplexing and a new computer installed in Washington, D.C. The total cost is \$7,948,000, which is the lowest cost of all options considered. Costs are less than option 2 (one region with switcher in Phoenix) costs, primarily due to one-time computer hardware and software costs, and in recurring line costs. Other differences are minor.

Figure 16 shows cost details for option 3 without multiplexing, indicating a cost savings of \$276,700 over the 7-year network life due to multiplexing. From 1977 through 1979 annual savings are \$60,000 with five multiplexing sites; from 1980 through 1983 annual savings are \$24,000 with four multiplexing sites.

OPTION: 3
REMARKS: 1 SWITCHER DC, WITH MULTIPLEXING

ITEM	CALENDAR YEAR									TOTAL
	1975	1976	1977	1978	1979	1980	1981	1982	1983	
I. ONE-TIME COSTS										
1. LINES		15	-	-	16	-	-	-	-	31
2. COMPUTER HARDWARE		759	-	-	-	-	-	-	-	759
3. COMPUTER SOFTWARE		294	-	-	-	-	-	-	-	294
4. FACILITIES		50	-	-	-	-	-	-	-	50
II. RECURRING COSTS										
1. LINES			508	508	508	662	662	662	662	4172
2. SWITCHERS			96	96	96	111	111	111	111	732
3. FACILITIES			11	11	11	11	11	11	11	77
III. OPERATING PERSONNEL			152	152	152	152	152	152	152	1064
IV. ENGINEERING	385	307	77							769
ANNUAL SUBTOTALS	385	1425	844	767	783	936	936	936	936	
										OVERALL TOTAL 7948

Fig. 15. Cost details

OPTION: 3
 REMARKS: 1 SWITCHER DC, WITHOUT MULTIPLEXING

ITEM	CALENDAR YEAR									
	1975	1976	1977	1978	1979	1980	1981	1982	1983	TOTAL
I. ONE-TIME COSTS										
1. LINES		15.3	-	-	16.0	-	-	-	-	31.3
2. COMPUTER HARDWARE		759	-	-	-	-	-	-	-	759.0
3. COMPUTER SOFTWARE		294	-	-	-	-	-	-	-	294.0
4. FACILITIES		50	-	-	-	-	-	-	-	50.0
II. RECURRING COSTS										
1. LINES			568	568	568	686.2	686.2	686.2	686.2	4448.8
2. SWITCHERS			95.8	95.8	95.8	111.4	111.4	111.4	111.4	733
3. FACILITIES			10.8	10.8	10.8	10.8	10.8	10.8	10.8	75.6
III. OPERATING PERSONNEL			152	152	152	152	152	152	152	1064
IV. ENGINEERING	385	307	77							769
ANNUAL SUBTOTALS	385	1425.3	903.6	826.6	842.6	960.4	960.4	960.4	960.4	
OVERALL TOTAL										8224.7

Fig. 16. Cost details

4. Option 4

a. Description.

General description. Option 4 is a two-region configuration with one regional switcher located in Phoenix serving the western states (region 1), and the second regional switcher located in Washington, D. C. serving the eastern states (region 2). Each switcher handles state-to-state and state-to-national traffic for its own region. Regions communicate with each other through inter-regional lines between the regional switchers.

Costing in option 4 was done assuming new computers at each regional switcher. Additionally the required upgrading of existing computer facilities in Phoenix was considered in order to use the NLETS computer as the western switcher.

As in option 3, a minimum traffic analysis was conducted for option 4 to determine the sensitivity of total costs to lower than predicted traffic levels. Results of the minimum traffic analysis are presented in Section VI.

Topology. The two-region topology of option 4 consists of two basic star networks, one centered at a regional switcher in Phoenix and one centered at a regional switcher in Washington, D. C. The topology is shown in Fig. 17. As in all multiple-region configurations, full-duplex inter-region lines connect the regional switchers.

The boundary between the two regions was manually adjusted to provide a clean delineation of regions and a minimum cost connection of system terminations to the switchers.

Constraints. The topology program was run for option 4 with Phoenix and Washington, D. C. pre-loaded as regional switchers. Another topology run was made allowing the program to specify optimum switcher locations. The program selected Washington, D. C. as the best region 2 switcher location and Utah as the best region 1 switcher location. The total cost difference between using Utah and Arizona amounted to only 3% of the total.

Adjustment of the boundary between the two regions was accomplished by assigning each state individually to its appropriate region before running the program.

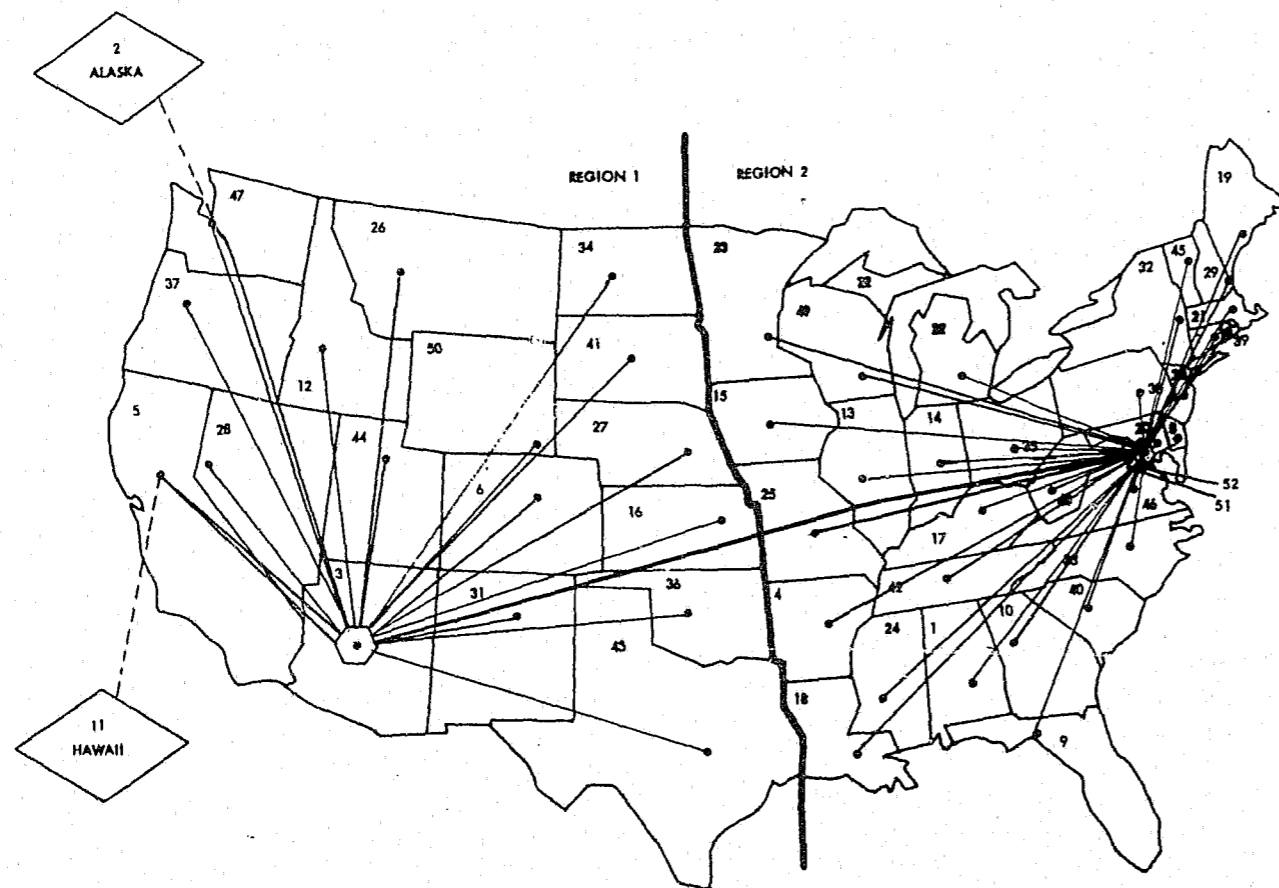

Fig. 17. Option 4. Two-region network

Multiple-region networks (options 4 through 9) do not use multiplexing techniques because line lengths progressively get shorter as the number of regions increases, making the use of multiplexing a negligible cost benefit.

b. Cost. Figure 18 shows cost details for option 4 with new computers at both regional switcher sites. Cost details assuming a new computer installation at Washington, D. C. only, with an upgraded version of existing hardware at Phoenix, are shown in Fig. 19.

Unlike option 2, the cost for considering an NLETS upgrade in option 4 exceeds the cost of implementing new computers by \$321, 000 over the 7-year life of the network. The principal differences contributing to this figure are higher one-time computer costs and recurring switcher costs for the NLETS upgrade version. Line costs remain the same in both cases.

5. Option 5

a. Description.

General description. Option 5 is a five-region network with regional switchers located in capital cities of Colorado, Illinois, Georgia, New York, and Washington, D. C. This option represents the first network configuration with more than two regional switchers and a first step toward consideration of more distributed networks.

Topology. The five-region topology of option 5 consists of five basic star networks centered at locations within each region that provide the least total message miles (message moment) to all system terminations serviced by the region. The regional switcher locations for each region are:

- Region 1: Washington, D. C.
- Region 2: Denver, Colorado
- Region 3: Albany, New York
- Region 4: Springfield, Illinois
- Region 5: Atlanta, Georgia

The topology for option 5 is shown in Fig. 20. As in option 4, the boundaries between regions were manually adjusted to provide a minimum cost connection of system terminations to the switchers.

OPTION: 4

REMARKS: 2 SWITCHERS, NEW COMPUTERS

ITEM	CALENDAR YEAR									
	1975	1976	1977	1978	1979	1980	1981	1982	1983	TOTAL
I. ONE-TIME COSTS										
1. LINES		16	-	-	15	-	-	-	-	31
2. COMPUTER HARDWARE		913	-	-	-	-	-	-	-	913
3. COMPUTER SOFTWARE		294	-	-	-	-	-	-	-	294
4. FACILITIES		85	-	-	-	-	-	-	-	85
II. RECURRING COSTS										
1. LINES			461	461	461	577	577	577	577	3691
2. SWITCHERS			111	111	111	129	129	129	129	849
3. FACILITIES			19	19	19	19	19	19	19	133
III. OPERATING PERSONNEL			171	171	171	171	171	171	171	1197
IV. ENGINEERING	500	400	100							1000
ANNUAL SUBTOTALS	500	1708	862	762	777	896	896	896	896	

OVERALL TOTAL 8193

Fig. 18. Cost details

OPTION: 4

REMARKS: 2 SWITCHERS, USING UPGRADED NLETS COMPUTER

ITEM	CALENDAR YEAR									
	1975	1976	1977	1978	1979	1980	1981	1982	1983	TOTAL
I. ONE-TIME COSTS										
1. LINES		16	-	-	15	-	-	-	-	31
2. COMPUTER HARDWARE		1104	-	-	-	-	-	-	-	1104
3. COMPUTER SOFTWARE		294	-	-	-	-	-	-	-	294
4. FACILITIES		85	-	-	-	-	-	-	-	85
II. RECURRING COSTS										
1. LINES			461	461	461	577	577	577	577	3691
2. SWITCHERS			133	133	133	145	145	145	145	979
3. FACILITIES			19	19	19	19	19	19	19	133
III. OPERATING PERSONNEL			171	171	171	171	171	171	171	1197
IV. ENGINEERING	500	400	100							1000
ANNUAL SUBTOTALS	500	1899	884	784	799	912	912	912	912	

OVERALL TOTAL 8514

Fig. 19. Cost details

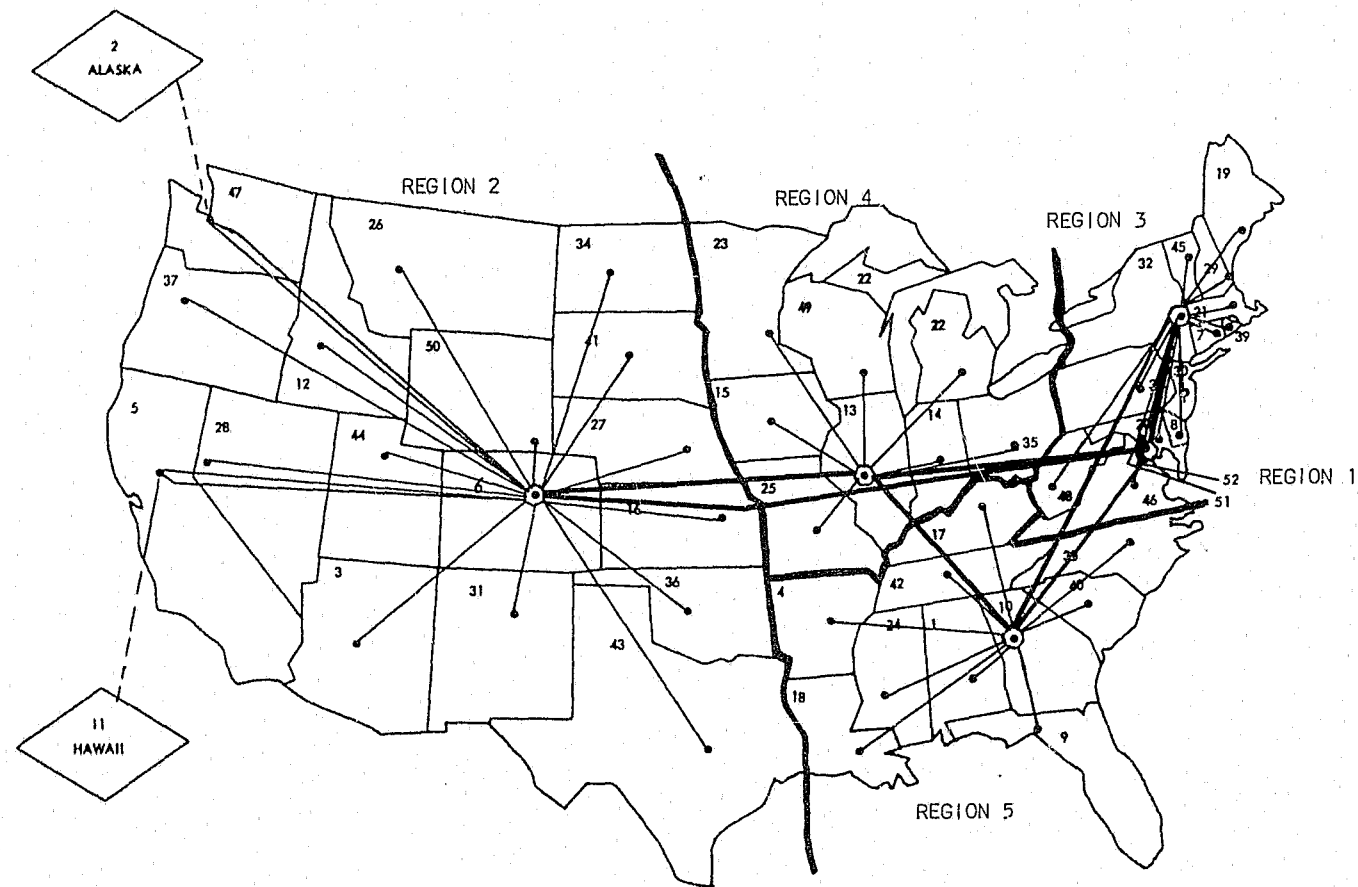

Fig. 20. Option 5. Five-region network configuration: 1979-1983

Constraints. The topology program was run for option 5 with the specification that five optimum (least cost) switcher locations be determined by the software algorithm outlined in Section III. Regional boundary lines were then manually adjusted by assigning specific states to each region, and a final five-region topology run was made.

The inter-region line optimization algorithm described in Section III resulted in the assignments of 1983 inter-region lines given in Table 7. These inter-region lines are shown in the option 5 topology of Fig. 20. Lower traffic levels experienced up through 1979 before the normal upgrade result in the inter-region line assignments also presented in Table 7. Note that in these inter-region line selections, no regional switcher is connected to another through more than one intermediate regional switcher.

Table 7. Inter-region line assignments

Inter-region lines: 1983			Inter-region lines: through 1979		
Region number		Line capacities, bps	Region number		Line capacities, bps
From	To		From	To	
1	2	9600, 9600	1	3	9600
1	3	9600, 4800	1	4	9600, 7200
1	4	9600, 9600	1	5	9600
1	5	9600, 4800	2	4	7200
2	4	4800	2	5	4800
3	5	4800	3	4	7200
4	5	4800	4	5	4800

b. Cost. Figure 21 shows cost details for option 5 with new computers at all regional switcher sites. The total 7-year cost for option 5 is \$9,446,000. The cost is slightly higher than that of either options 3 and 4. The total costs for each of the options 3, 4, and 5 are the only ones below \$10,000,000 in the nine options considered.

The higher cost of option 5 over options 3 and 4 is due primarily to the larger number of computers, facilities, and operating personnel. These increases are evidenced in both one-time and in recurring costs.

Total line costs, however, are less for the five-region case. These figures indicate (from a cost standpoint only) the nature of the tradeoff between an increasing number of regional switchers and the accompanying reduction in line costs. That is, costs associated with the implementation of five regional switchers offset line cost savings so as to increase total 7-year period costs by about \$1,250,000 over the two-region case of option 4.

OPTION: 5
REMARKS: 5 SWITCHERS

ITEM	CALENDAR YEAR									TOTAL
	1975	1976	1977	1978	1979	1980	1981	1982	1983	
I. ONE-TIME COSTS										
1. LINES		18	-	-	15	-	-	-	-	33
2. COMPUTER HARDWARE		1368	-	-	-	-	-	-	-	1368
3. COMPUTER SOFTWARE		294	-	-	-	-	-	-	-	294
4. FACILITIES		190	-	-	-	-	-	-	-	190
II. RECURRING COSTS										
1. LINES			422	422	422	503	503	503	503	3278
2. SWITCHERS			150	150	150	179	179	179	179	1166
3. FACILITIES			44	44	44	44	44	44	44	308
III. OPERATING PERSONNEL			228	228	228	228	228	228	228	1596
IV. ENGINEERING	607	485	121							1213
ANNUAL SUBTOTALS	607	2355	965	844	859	954	954	954	954	

OVERALL TOTAL 9446

Fig. 21. Cost details

6. Option 6

a. Description.

General description. Option 6 is a 50-switcher network constructed from the basic five-region configuration presented in option 5. Five major redundant regional switchers are located in capital cities of Colorado, Illinois, Georgia, New York, and Washington, D.C., as they were in the previous option. Within each region, system terminations are comprised of nonredundant state switchers which are connected through multiple pathways to their assigned regional switchers.

This option represents the most highly distributed network configuration of the nine options considered. The purpose of this option is to provide a configuration to assess the relative value of a highly redundant topology with maximum nodal switching capability.

Topology. The topology for the 50-switcher option 6 case is shown in Fig. 22. Redundant computers are located at the five major regional switching centers. Each system termination within the continental United States served by regional switchers consists of a nonredundant computer capable of message switching. These switchers are interconnected in groups of two or more to form a series of loops in each region providing alternate routing for message flow. Alaska and Hawaii are the only system terminations in option 6 without message switching capability.

Constraints. System terminations within each region, with the exception of Alaska and Hawaii, are connected such that each system termination has at least one alternate path to its regional switcher. Each system termination so connected is a computerized state switcher with message switching capability. The result is a series of loop structures emanating from each regional switcher as shown in Fig. 22. When an odd number of state switchers are to be connected, or where geography dictates, specific system terminations (state switchers) may belong to two loops. Examples of this connectivity are Oregon (state 37), Oklahoma (state 36), Mississippi (state 24), and Michigan (state 22).

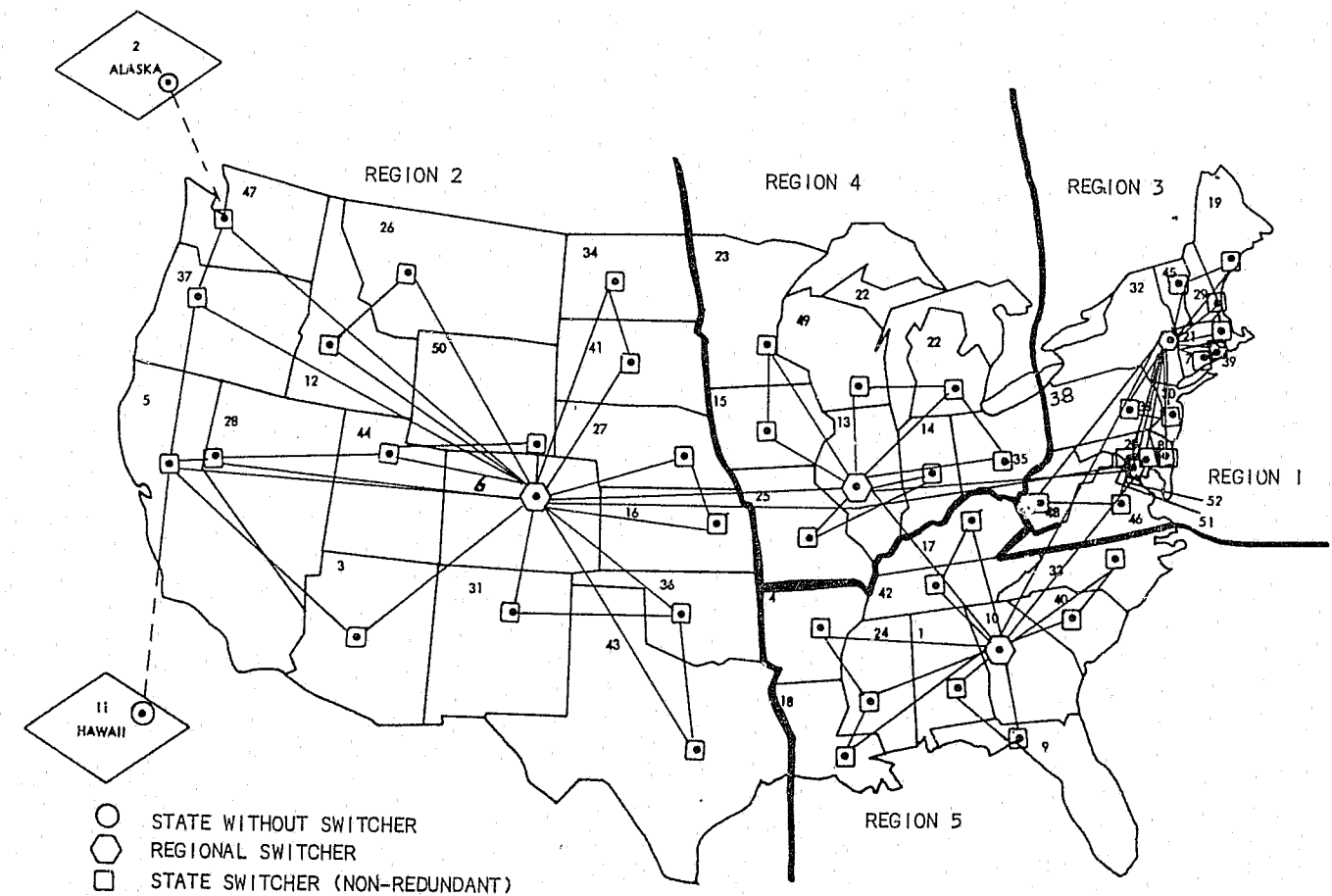

Fig. 22. Option 6. 50-switcher network configuration: 1979-1983

Additional line costs caused by looping were calculated manually. Because the regional switchers are located as they are in the five-region case of option 5, the inter-region line assignments are the same as in option 5 for 1983 and 1979.

b. Cost. The cost details for option 6 are shown in Fig. 23. The total 7-year cost of \$24,640,000 for option 6 is second only to option 7, the two-region case that is expandable to satellite video and data handling capabilities. The high cost of option 6 is due principally to one-time and recurring costs for switching computers, facilities, and operating personnel.

Line costs are not significantly increased over the two- and five-region cases, as the outer connections on each loop are relatively short.

Computer software costs are only slightly higher (\$340,000 compared to \$294,000). The increase is due to an extended software set required for inter-computer communications and traffic routing management, which is more sophisticated when multiple routing is implemented at the system termination level.

7. Option 7

a. Description.

General description. Option 7 entails four phases of implementation (Table 8) in which a ground-based two-region network is upgraded to provide satellite video and data-handling capability, both inter-regionally and to selected high traffic states. The eventual configuration uses a single switcher that services all system terminations.

The purpose of option 7 is to evaluate the enhancement of network capabilities by the inclusion of satellite data and video channels through leased commercial satellites.

OPTION: 6
REMARKS: 50 SWITCHERS

ITEM	CALENDAR YEAR									TOTAL
	1975	1976	1977	1978	1979	1980	1981	1982	1983	
I. ONE-TIME COSTS										
1. LINES		25	-	-	10	-	-	-	-	35
2. COMPUTER HARDWARE		3750	-	-	-	-	-	-	-	3750
3. COMPUTER SOFTWARE		340	-	-	-	-	-	-	-	340
4. FACILITIES		1765	-	-	-	-	-	-	-	1765
II. RECURRING COSTS										
1. LINES			491	491	491	537	537	537	537	3621
2. SWITCHERS			439	439	439	462	462	462	462	3165
3. FACILITIES			422	422	422	422	422	422	422	2954
III. OPERATING PERSONNEL			1083	1083	1083	1083	1083	1083	1083	7581
IV. ENGINEERING	720	575	144	-	-	-	-	-	-	1439
ANNUAL SUBTOTALS	720	6445	2579	2435	2445	2504	2504	2504	2504	

OVERALL TOTAL 24,640

Fig. 23. Cost details

Table 8. Four phases of implementation

Phase	Operational dates	Description
7-a	Jan 1977 - June 1977	Two-region terrestrial network with regional switchers at Washington, D.C. and Phoenix; similar to option 4, but with expansion capability
7-b	July 1977 - Sept 1978	Satellite ground stations are installed at Washington, D.C. and Phoenix, Arizona. The satellite link is used for data transmission between these two points
7-c	Oct 1978 - Sept 1979	Six additional satellite ground stations are installed. Terrestrial links from these six locations are replaced by satellite links and video capability is provided
7-d	Oct 1979 - Dec 1983	Six additional satellite ground stations are installed. Terrestrial links are replaced by satellite links. The western switcher is phased out, but Arizona maintains its satellite link connection to the regional switcher

Topology. The network topology for phase 7-a of option 7 is identical to that of option 4 pictured in Fig. 17. Phase 7-a is also shown in block diagram form in Fig. 24a.

In phase 7-b the terrestrial eastern and western star networks servicing system terminations are retained, while the inter-region lines (one 9600-bps line and one 4800-bps line) are replaced by a satellite link between Washington, D.C. and Phoenix. This configuration is shown in Fig. 25.

Figure 26 shows phase 7-c where satellite communications capability is added for six states: Texas and California in the west and Florida, Michigan, Illinois and New York in the east.

In the last implementation phase (7-d shown in Fig. 27), the western switcher located at Phoenix is discontinued and the eastern switcher at Washington D.C. serves the entire network. Texas and California satellite links are unchanged, and Arizona maintains its satellite link. All other system terminations previously in the western region are connected by way of new ground lines to the eastern switcher. Also provided with satellite communications capability in phase 7-d are six new eastern states: Missouri, Georgia, North Carolina, Ohio, Pennsylvania, and Massachusetts, bringing the total number of satellite stations to 14.

Constraints. Phase 7-a of option 7 is almost identical to the two-region case of option 4. The exception is that additional line interface units are installed at the eastern switcher in 1976 and are sufficient to handle the final line load of phase 7-d when the western switcher is phased out.

All system terminations using satellite data links in phases 7-c and 7-d interface to the network through the eastern switcher. Each satellite ground station is capable of simultaneously transmitting to and receiving data from the eastern switcher over full-duplex data channels. Communications through the satellite link must be full duplex to maintain reasonable line throughput with the delays inherent in satellite transmission. The eastern switcher Earth station can simultaneously transmit to and receive from all system termination Earth stations. Continuous 24-h unattended operation is required of satellite links in addition to the general NALECOM functional requirements outlined in Section II. Typical data communication configurations for phases 7-a and

V-34

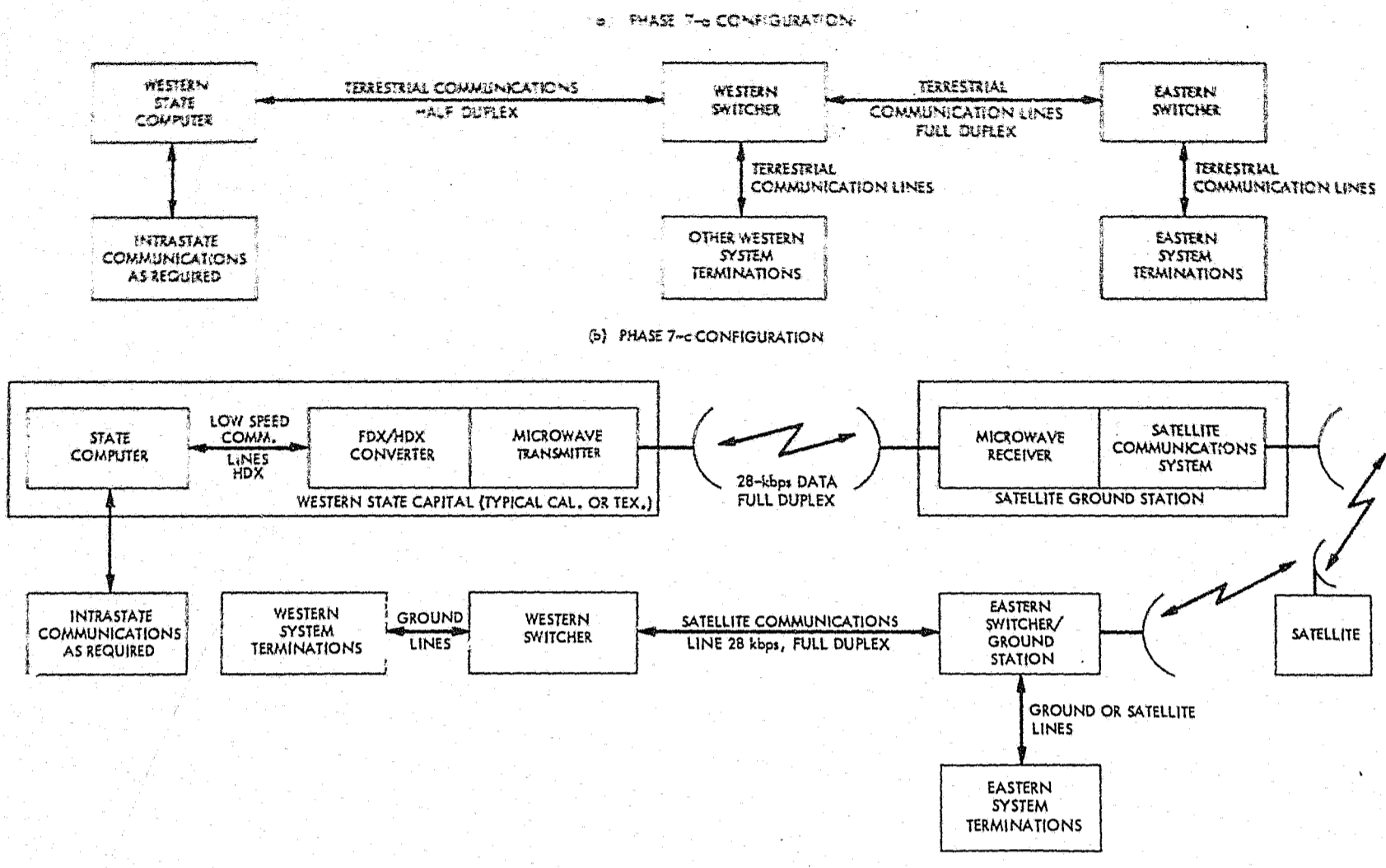

Fig. 24. Option 7. Typical data communications configuration for a western state in phases 7-a and 7-c

V-35

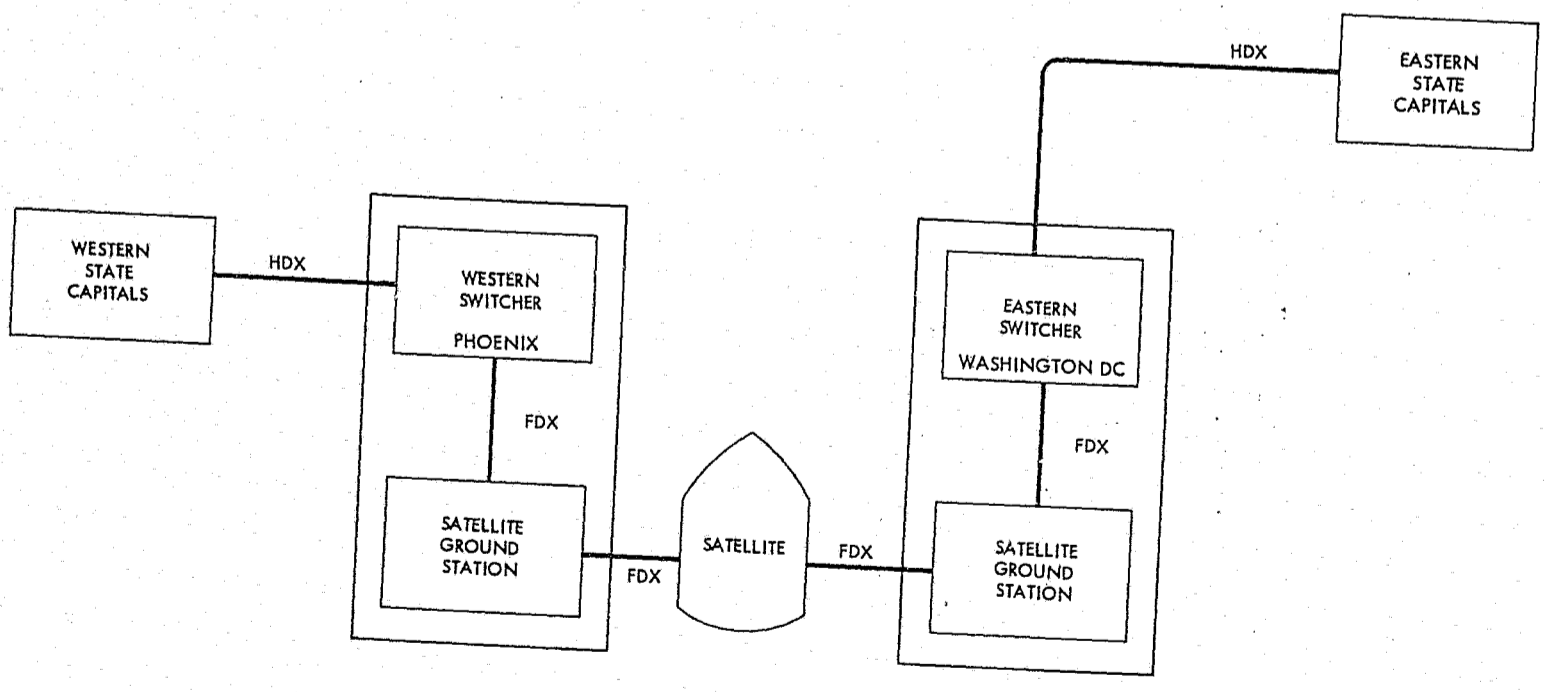

Fig. 25. Option 7. Phase 7-b network configuration

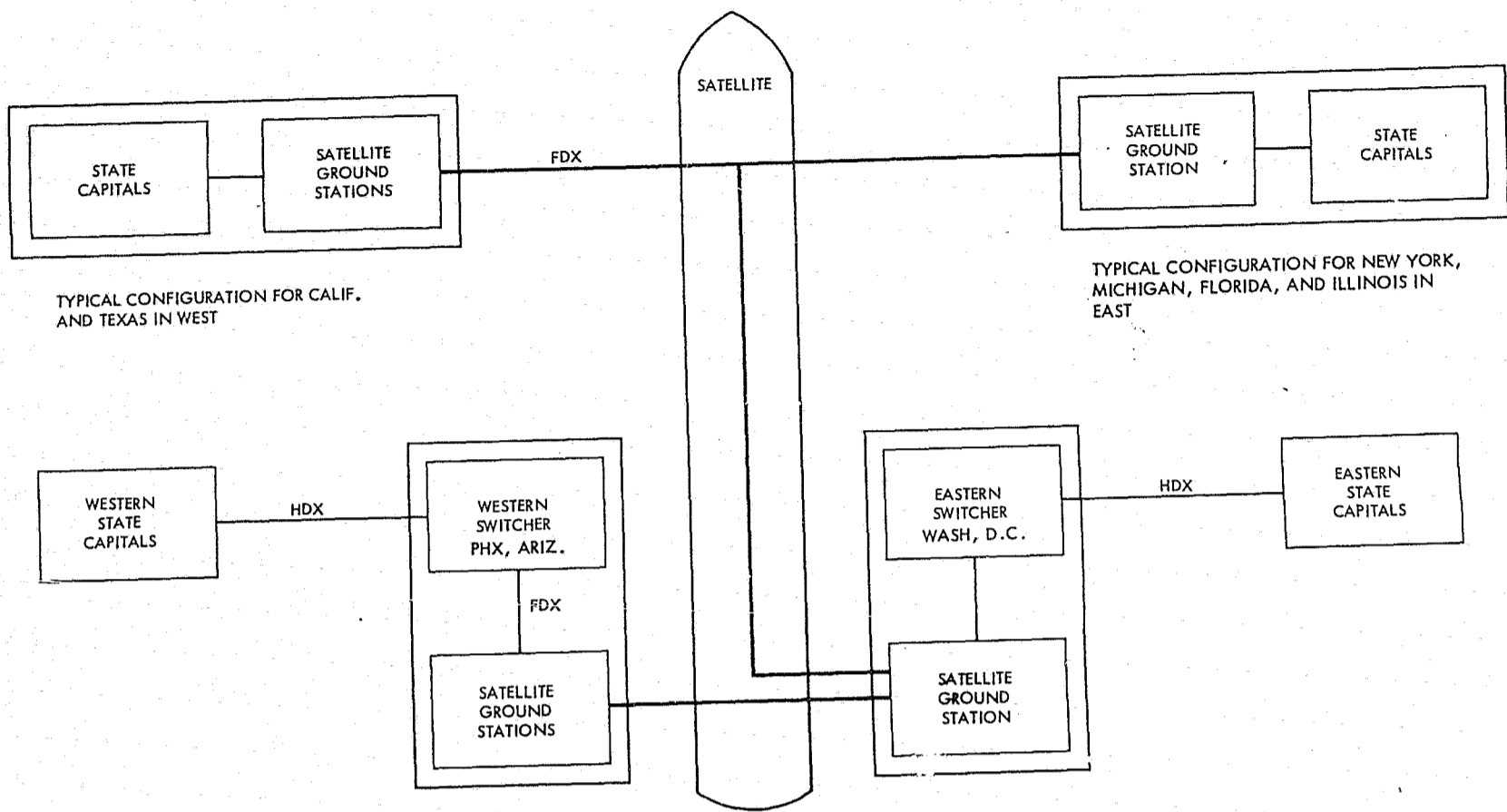

Fig. 26. Option 7. Phase 7-c network configuration

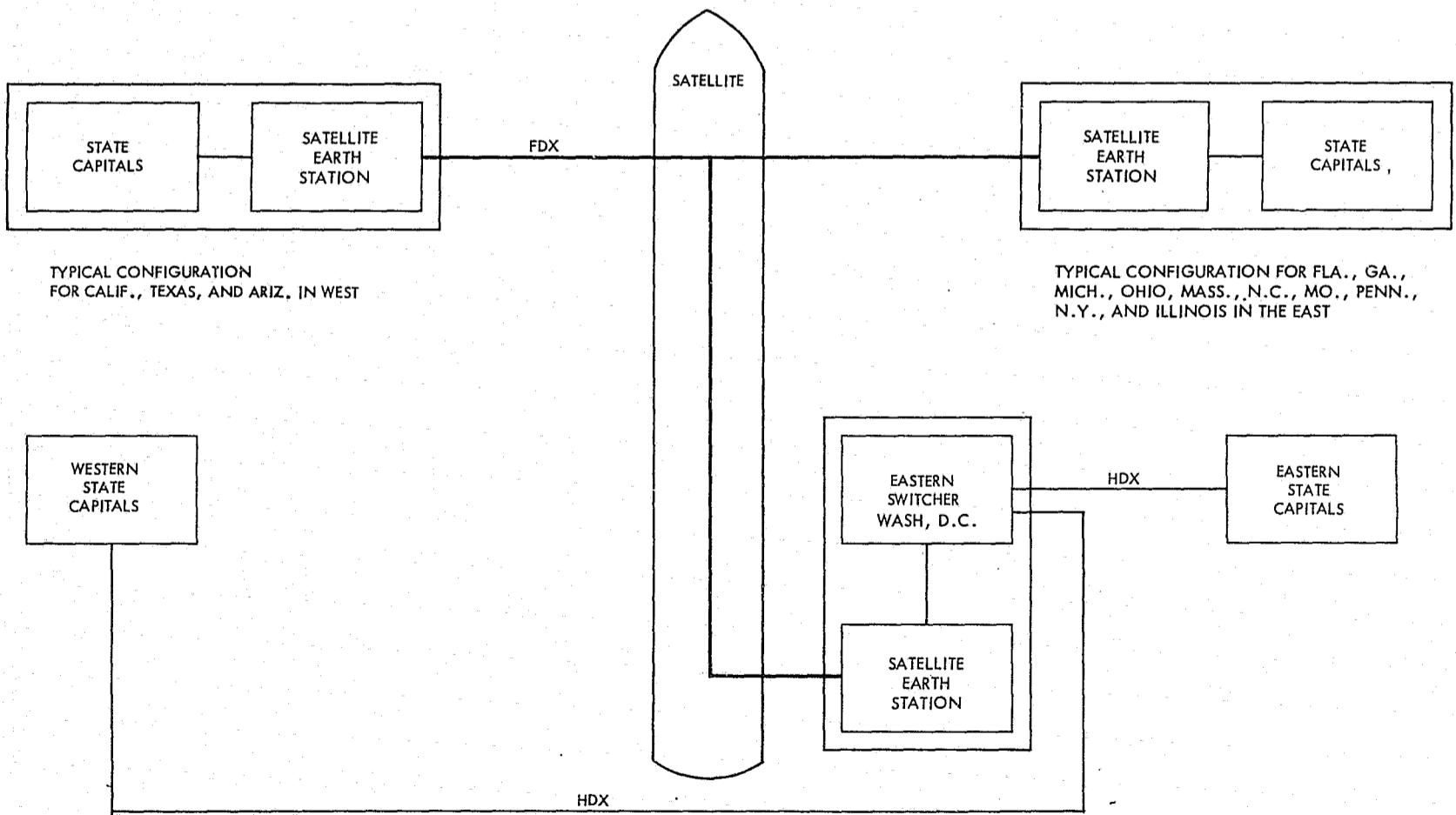

Fig. 27. Option 7. Phase 7-d network configuration

7-c are shown in Fig. 24. This configuration is typical of either California or Texas. Eastern states equipped with satellite capability have similar configurations.

Video capability is also provided for satellite links. Each of the satellite Earth stations is capable of originating video transmission, and all Earth stations are capable of simultaneously receiving the video signal broadcast through the domestic communications satellite. Video channel usage for the space link is scheduled through a commercial satellite.

A typical ground station block diagram is shown in Fig. 28. This configuration is typical of a station used at a system termination for data communications to and from the eastern switcher, as provided during phases 7-c and 7-d, and also the western switcher during phase 7-b. The master station at the eastern switcher is similar, but has additional data coders/decoders so as to communicate with all the slave stations.

NALECOM-provided microwave radio links are used in areas where local commercial communication capabilities are not adequate to provide communications from satellite Earth stations to the physical locations of system terminations.

Full-duplex to half-duplex converters are used to provide the half-duplex protocol interface to system terminations.

Microwave links average about 30 mi in length and, in general, one repeater station is employed. Microwave full-duplex data channels can simultaneously transmit and receive data up to 56 kbps on a redundant channel. The microwave links can also handle half-duplex black and white video. As in the case with satellite links, all microwave links are capable of continuous 24-h unattended operation and meet all general functional requirements of the NALECOM Network.

b. Cost. The total 7-year cost for option 7 is \$34,488.00. Cost details over the four implementation phases are shown in Fig. 29. The installation periods and operational periods for each phase are given in Table 9.

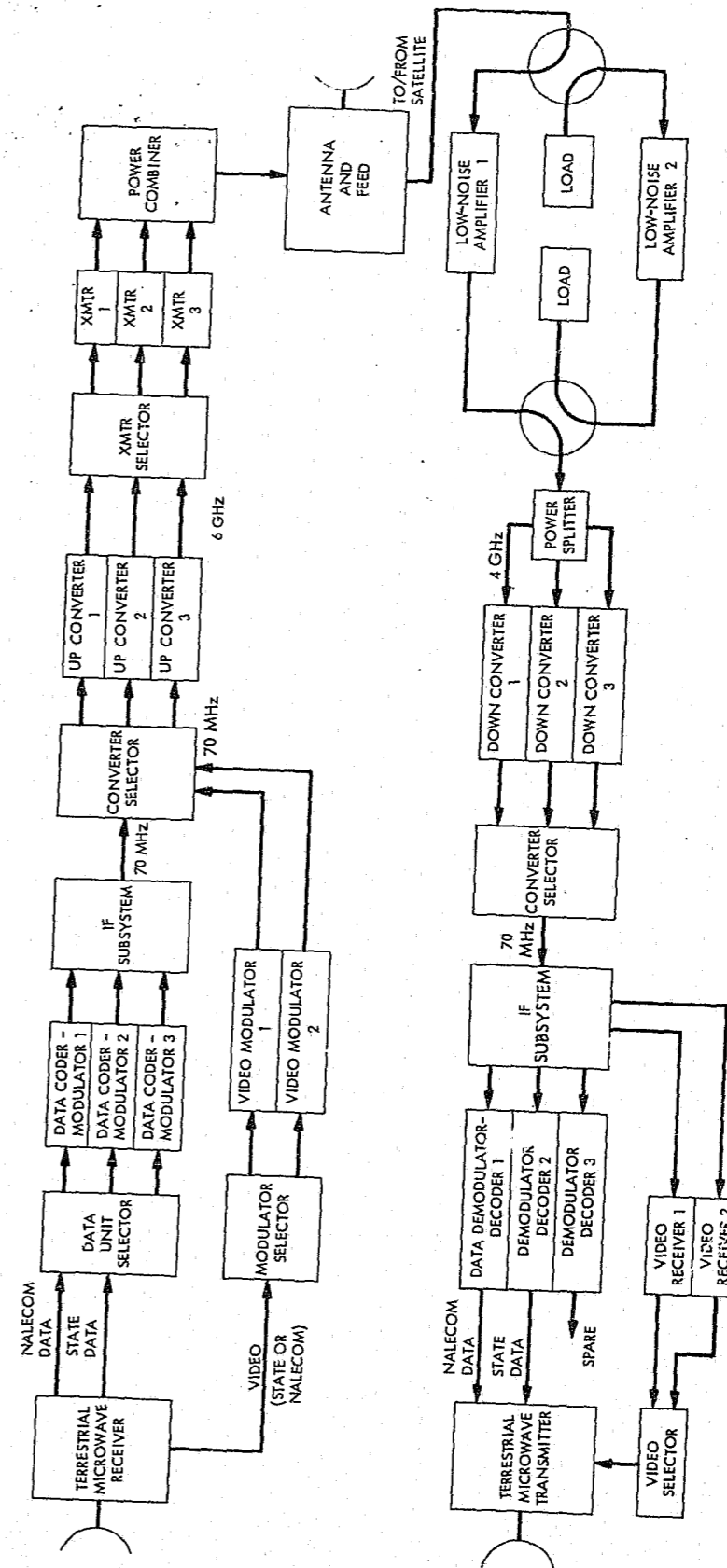

Fig. 28. Typical ground station

OPTION: 7
REMARKS: 2 SWITCHERS PLUS SATELLITES

ITEM	CALENDAR YEAR											
	1975	1976	1977			1978		1979	1980	1981	1982	1983
I. ONE-TIME COSTS												
1. LINES		16	-	-		8	-	-	-	-	-	24
2. COMPUTER HARDWARE		1017	1533	5176	-	5044	-	-	-	-	-	12770
3. COMPUTER SOFTWARE		294	-	40	-	-	-	-	-	-	-	334
4. FACILITIES		85	-	-	-	-	-	-	-	-	-	
II. RECURRING COSTS												
1. LINES			231	406	608	278	832	457	1829	1829	1829	10128
2. SWITCHERS			55	165	247	226	678	381	1524	1524	1524	7848
3. FACILITIES			10	10	14	5	14	3	11	11	11	100
III. OPERATING PERSONNEL			86	86	128	43	128	38	152	152	152	1117
IV. ENGINEERING	500	400	300	200	200	200	182	100				232
ANNUAL SUBTOTALS	500	1812	2215	6083	1197	5804	1834	979	3516	3516	3516	

OVERALL TOTAL 34,488

Fig. 29. Cost details

Table 9. Installation and operational periods

Phase	Installation period	Operational period
7-a	1976	Jan 1977 - June 1977 (0.5 yr)
7-b	Jan 1977 - June 1977	July 1977 - Sept 1978 (1.25 yr)
7-c	July 1977 - Sept 1978	Oct 1978 - Sept 1979 (1.0 yr)
7-d	Oct 1978 - Sept 1979	Oct 1979 - Dec 1983 (4.25 yr)

The vertical lines in Fig. 29 dividing the years 1977, 1978, and 1979 denote the dates in those years that successive phases become operational. Yearly costs are prorated according to the above schedule.

In 1976, one-time installation costs are shown in preparation for phase 7-a. One-time cost entries under computer hardware for the years 1977 and 1978 reflect initial and upgrading costs for installation of microwave links, ground stations, and full-duplex to half-duplex converters. A substantial portion of option 7 costs is in the installation and maintenance of these facilities. Complete microwave cost details are presented in Appendix D.

The one-time computer software cost in 1977 of \$40,000 is for full-duplex to half-duplex software. The one-time line cost of \$8,000 shown in 1978 is for the installation of lines from western system terminations to the eastern switcher in preparation for the phaseout of the western switcher in phase 7-d.

Recurring costs for lines include space link lease costs for data and video channels.

Total annual facility recurring costs decrease in 1980 when the western switcher is phased out, as do operating personnel costs.

Engineering costs for option 7 are greater than for the other options and are spread over the total implementation period to 1980.

8. Option 8

a. Description.

General description. Option 8 is a ten-region network with regional switchers located in capital cities of California, Colorado, Texas, Florida, Illinois, Ohio, Maryland, New York, Massachusetts, and Washington, D.C. This option provides an intermediate evaluation step in the consideration of multi-regional network configurations.

Topology. The ten-region topology of option 8 consists of ten star networks centered at locations within each region that provide the least total message miles between system terminations serviced by each region and the appropriate regional switcher. The regional switcher assignments for each region are:

- Region 1: Washington, D. C.
- Region 2: Sacramento, California
- Region 3: Denver, Colorado
- Region 4: Boston, Massachusetts
- Region 5: Albany, New York
- Region 6: Austin, Texas
- Region 7: Annapolis, Maryland
- Region 8: Tallahassee, Florida
- Region 9: Columbus, Ohio
- Region 10: Springfield, Illinois

The topology for option 8 is shown in Fig. 30. The boundaries between regions were manually adjusted to provide a minimum cost connection of system terminations to the switchers.

Constraints. The topology program was constrained in the run for option 8 to select the ten optimum (least cost) locations for regional switchers in accordance with the software algorithm outlined in Section III. A second

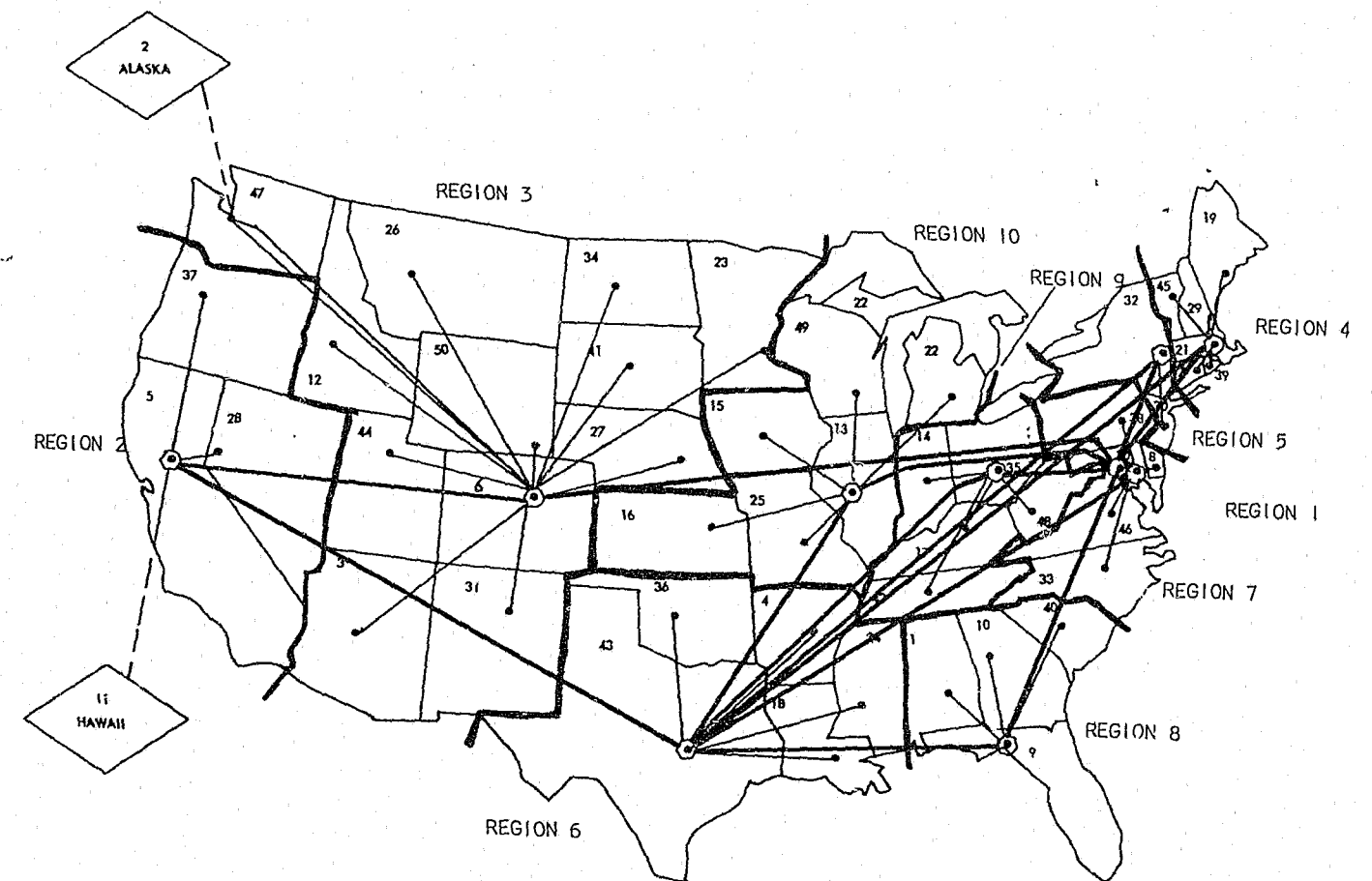

Fig. 30. Option 8. Ten region network configuration: 1979-1983

CONTINUED

1 OF 3

program run was then made with regional boundaries adjusted by assigning specific states to the previously determined ten regional switchers.

The inter-region line optimization section of the topology program made assignments for 1983 inter-region lines as given in Table 10. The lines are illustrated in Fig. 30.

Inter-region line connections for the lower 1979 traffic levels before the normal network upgrade remain the same as in 1983; however, line capacities are lower. Single line assignments of 4800 bps are made for all inter-region lines, with the exception of a 9600-bps line between regions 1 and 10 and a 7200-bps line between regions 2 and 3. In option 8, all regional switching computers are fully redundant.

b. Cost. Cost details for option 8 are presented in Fig. 31 and show a 7-year total cost of \$11,670,000. The ten-region cost is slightly less than option 1 total costs.

As is the case with the 5-, 25-, and 50-switcher cases, the principal contribution to increased costs in option 8 over options 3 and 4 is due to one-time computer and facilities costs and recurring costs for switchers, facilities, and operating personnel.

Table 10. Inter-region line assignments: 1983

Region number		Line capacities, bps	Region number		Line capacities, bps
From	To		From	To	
1	3	9600	2	6	7200
1	4	9600	4	6	4800
1	5	9600	5	6	7200
1	7	9600	6	7	4800
1	8	9600	6	8	4800
1	9	7200	6	9	4800
1	10	9600, 7200	6	10	4800
2	3	9600			

OPTION: 8
REMARKS: 10 SWITCHERS

ITEM	CALENDAR YEAR									
	1975	1976	1977	1978	1979	1980	1981	1982	1983	TOTAL
I. ONE-TIME COSTS										
1. LINES		18	-	-	12	-	-	-	-	30
2. COMPUTER HARDWARE		1952	-	-	-	-	-	-	-	1952
3. COMPUTER SOFTWARE		294	-	-	-	-	-	-	-	294
4. FACILITIES		365	-	-	-	-	-	-	-	365
II. RECURRING COSTS										
1. LINES			429	429	429	496	496	496	496	3271
2. SWITCHERS			225	225	225	243	243	243	243	1647
3. FACILITIES			86	86	86	86	86	86	86	602
III. OPERATING PERSONNEL			323	323	323	323	323	323	323	2261
IV. ENGINEERING	624	499	125							1248
ANNUAL SUBTOTALS	624	3128	1188	1063	1075	1148	1148	1148	1148	

OVERALL TOTAL 11,670

Fig. 31. Cost details

Line recurring costs for options 5 and 8 (five-region and ten-region cases) are virtually the same and represent the lowest line maintenance costs of all of the options. The savings in line costs, however, are more than offset by hardware, facility, and personnel costs as the number of switchers increases.

9. Option 9

a. Description.

General description. Option 9 is a 25-switcher network constructed from the five-region configuration presented in option 5. Five major redundant regional switchers are located in state capital cities of Colorado, Illinois, Georgia, New York, and in Washington, D.C. Within each region, a basic star network provides connections to system terminations that do not have resident state switchers. There are 20 non-redundant state switchers assigned among the regions and connected in loop configurations to one or more neighboring state switchers and to the regional switcher.

This option provides an intermediate evaluation step in the consideration of multi-regional, distributed network options.

Topology. The topology for the 25-switcher option 9 case is shown in Fig. 32. Redundant computers are located at the five major regional switching centers. Twenty state switchers are added to the network on the basis of traffic requirements to provide a total of 25 switchers. State switchers are nonredundant and connected together within each region in looped paths to provide alternate routing for higher traffic states. Other system terminations within each region are connected directly to their regional switchers in conventional star patterns.

Constraints. The 20 state switchers in option 9 are connected together such that each state switcher has at least one alternate path to its regional switcher. The loop structures created are similar to those in the 50-switcher case in that specific state switchers may belong to two loops, as is seen, for example, in the case of Michigan (state 22) and Kentucky (state 17) in Fig. 32.

Additional line costs due to looping were calculated manually. Inter-region line assignments remain the same as for options 5 and 6 for 1983 and 1979.

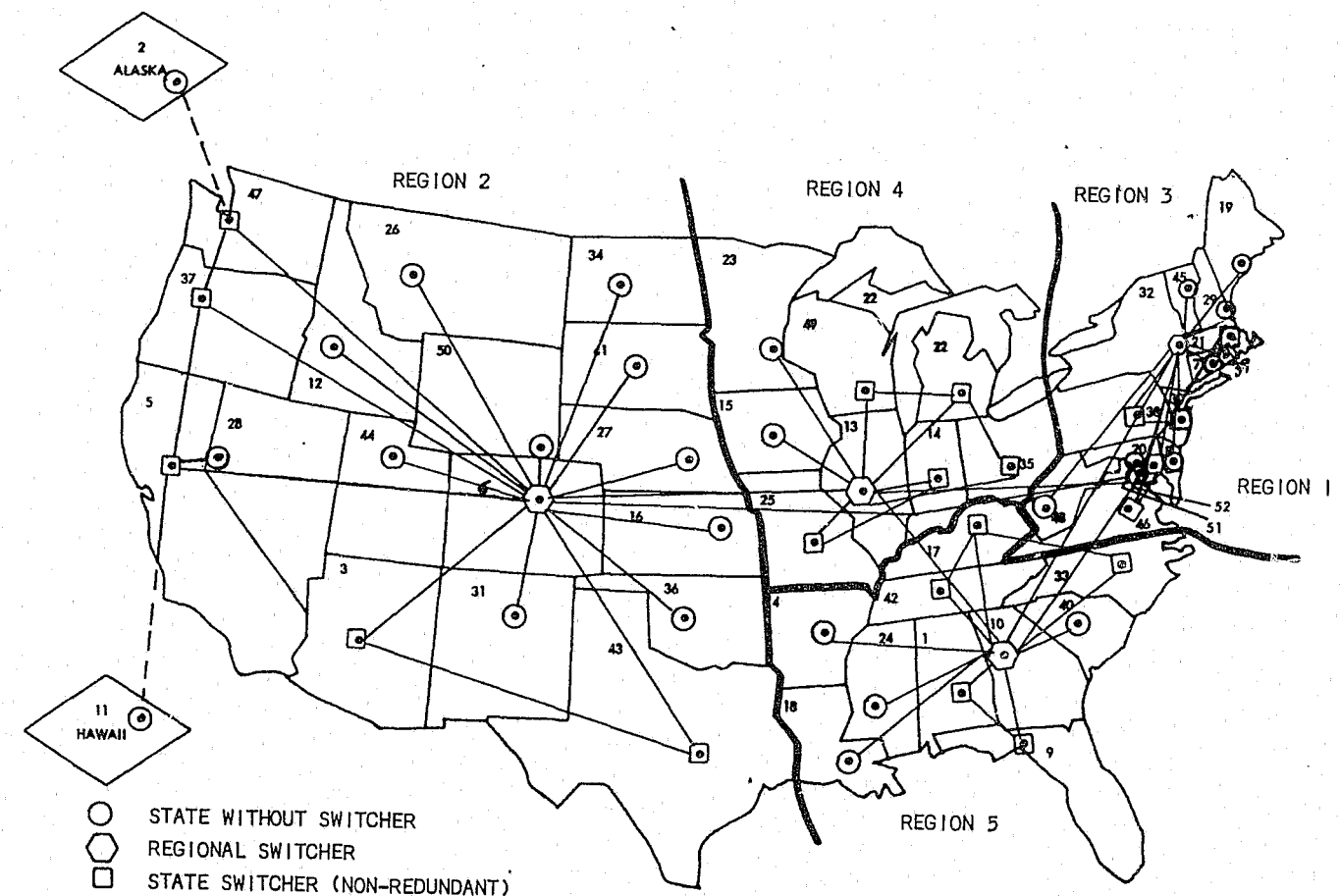

Fig. 32. Option 9. 25-switcher network configuration: 1979-1983

b. Cost. Cost details for option 9 are shown in Fig. 33. The total 7-year cost figure for option 9 is \$16,012,000. The cost for option 9 is exceeded only by option 7 with satellite capability and the 50-switcher case of option 6. Cost patterns in option 9 conform to those exhibited in multi-region options where cost increases are due primarily to increases in switchers, facilities, and operating personnel.

Seven-year line costs for option 9 are essentially no different from total line costs in option 6 (50-switcher case) or option 5 (five-region case).

Computer software one-time costs are slightly higher (\$340,000), as in option 6 where state switchers are employed, due to the extended software set required for inter-computer communications and traffic routing management.

OPTION: 9
REMARKS: 25 SWITCHERS

ITEM	CALENDAR YEAR									
	1975	1976	1977	1978	1979	1980	1981	1982	1983	TOTAL
I. ONE-TIME COSTS										
1. LINES	-	20	-	-	13	-	-	-	-	33
2. COMPUTER HARDWARE		2345	-	-	-	-	-	-	-	2345
3. COMPUTER SOFTWARE		340	-	-	-	-	-	-	-	340
4. FACILITIES		890	-	-	-	-	-	-	-	890
II. RECURRING COSTS										
1. LINES			449	449	449	481	481	481	481	3271
2. SWITCHERS			277	277	277	298	298	298	298	2023
3. FACILITIES			212	212	212	212	212	212	212	1484
III. OPERATING PERSONNEL			608	608	608	608	608	608	608	4256
IV. ENGINEERING	685	548	137	-	-	-	-	-	-	1370
ANNUAL SUBTOTALS	685	4143	1683	1546	1599	1599	1599	1599	1559	

OVERALL TOTAL 16,012

Fig. 33. Cost details

SECTION VI EVALUATION SUMMARY

This section summarizes the results of network evaluations for the nine options considered. The evaluation criteria summarized include quantitative costs, network response times, reliability, and qualitative criteria derived from responses to an evaluation form. The latter category consists of the five technical criteria: flexibility, ease of implementation, simplicity, privacy, and security. The approach to conducting these evaluations is discussed in Section IV.

A. COST

Total network 7-year costs for each option are tabulated on line 5 of the network comparison matrix shown in Fig. 34. Lines 1 through 4 give one-time, recurring, personnel, and engineering costs for each option. Total costs for each option are presented in bar graph form in Fig. 35.

Option 3, a single-switcher configuration with a switcher at Washington, D.C. is the least expensive of all options. Options 3, 4, and 5 have total costs less than \$10,000,000. Option 4 is a two-region network with switchers in Phoenix and Washington, D.C.; option 5 is a five-region network.

Personnel costs show a sharp increase as the number of regions increase from \$1,100,000 for option 3 (one region) to \$7,600,000 for the 50-region case of option 6.

Recurring costs are minimized in options 4 and 5, the two-region and five-region cases, respectively. This represents a minimum in the recurring cost tradeoffs between the longer lines required for single-switcher configurations and the higher recurring equipment costs for multiple-region cases. The high recurring cost in option 1, for example, is due to the line duplication inherent in maintaining two separate networks.

One-time costs increase as a function of the number of switchers slightly less than personnel costs do, moving from \$1,100,000 for option 3 to \$5,900,000 for the 50-region case of option 6. One-time costs are seen to remain relatively stable throughout options 1 to 4.

ITEM	PARAMETER	UNITS	NETWORK OPTION/NUMBER OF SWITCHERS									
			1	2	3	4	5	6	7	8	9	
			1+1	1 (PHX)	1 (DC)	2	5	50	2+5	10	25	
1	ONE-TIME COSTS	MS	1.4	1.3	1.1	1.3	1.9	5.9	13.2	2.6	3.6	TECHNICAL CRITERIA
2	RECURRING COSTS	MS	8.9	6.9	5.0	4.7	4.8	9.7	18.1	5.5	6.8	
3	PERSONNEL COSTS	MS	1.1	1.1	1.1	1.2	1.6	7.6	1.1	2.3	4.3	
4	ENGINEERING COSTS	MS	0.8	0.8	0.8	1.0	1.2	1.4	2.1	1.3	1.4	
5	TOTAL COSTS	MS	12.2	10.1	8.0	8.2	9.5	25	34.5	11.7	16.0	
6	RESPONSE TIMES											
	PRIORITY 1	SEC	2.2	2.2	2.2	2.4	2.4	1.9	2.4	2.9	2.4	
	PRIORITY 2	SEC	3.3	3.3	3.2	3.6	3.7	3.2	3.6	4.6	3.7	
	PRIORITY 3	SEC	6.0	5.1	5.9	6.6	6.8	6.0	6.6	8.5	6.8	
7	RELIABILITY	0-1	0.991	0.991	0.991	0.991	0.991	0.989	0.991	0.991	0.989	
8	FLEXIBILITY	0-100	56	61	61	56	46	32	56	40	38	
9	EASE OF IMPLEMENTATION	0-100	70	63	63	67	44	16	56	33	17	
10	SIMPLICITY	0-100	62	71	71	58	43	17	55	29	19	
11	PRIVACY	0-100	56	66	66	66	38	22	50	25	22	
12	SECURITY	0-100	52	54	54	52	44	37	52	45	37	
13	ACCEPTABILITY	0-100	SEE SECTION IV-C									NON- TECHNICAL CRITERIA
14	EASE IN SELECTION OF MANAGEMENT	0-100	SEE SECTION IV-C									
15	DECISION ON NETWORK SELECTION REQUIRED BY	DATE	SEE SECTION VI-E									

Fig. 34. Network comparison matrix

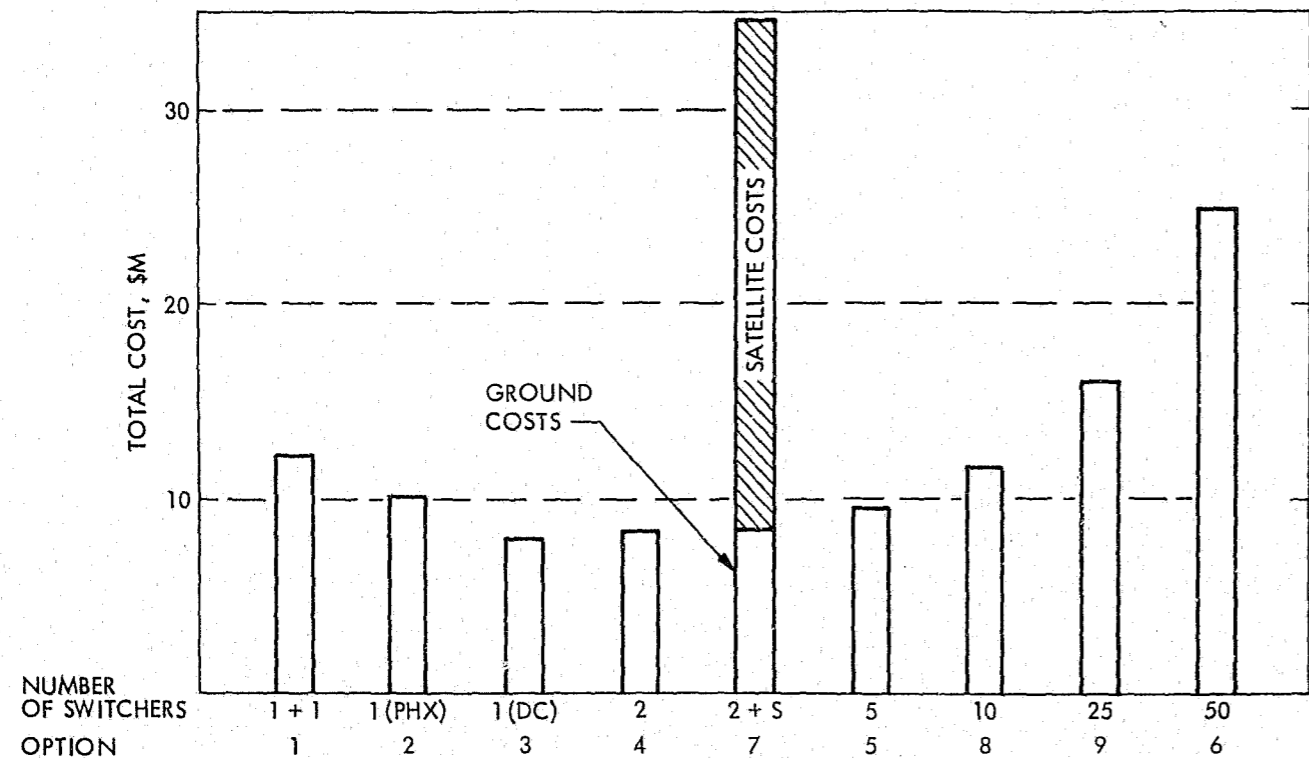

Fig. 35. Total cost summary

Engineering costs indicate the least fluctuation of all cost factors. The highest cost is associated with option 7. The high cost is due to the implementation of satellite video and data-handling capability. The greatest factor contributing to the cost increase in option 7 is in recurring costs followed closely by the increase in one-time costs.

B. RESPONSE TIMES

NALECOM one-way-transmission response-time goals between any two system terminations by message priority are:

Priority	Response time, s
1	7
2	7.5
3	30

Results of response-time calculations for total worst-case communication links for the topology of each option by priority are tabulated in item 6 of Fig. 34.

In all cases response times fall within the NALECOM design goals. No option exhibits significantly low response times compared with the other options. Therefore, response time is not a critical factor in the selection of options. Details of the delay analysis leading to the response-time values shown are presented in Appendix G.

C. RELIABILITY

Reliability figures are presented for each option in item 7 of Fig. 34. Each of the options show reliability (actually availability) figures of 0.991, with the exception of the 25- and 50-switcher cases where availability was calculated at 0.989.

In all cases the figures fall slightly short of the previously stated goal for availability of 0.993. However, it is felt that the calculated figures are

acceptable in that the average outages at 0.991 availability amount to about 12 min/day, which is close to the original goal of 10 min/day. Availability also can easily be improved at a low cost by the addition of dialup backup lines or redundant components at critical points.

The lower availability figure for options 6 and 9 result solely from connections to Alaska and Hawaii for option 6 and connections to Alaska, Hawaii, and Nevada for option 7. Worst-case availability for other system terminations is 0.991 for option 9 and 0.993 for option 6.

D. TECHNICAL EVALUATION CRITERIA

Total averaged ratings for the criteria discussed in this section are presented for each option in Fig. 36.

1. Flexibility

The single-region configurations of options 2 and 3 are considered to have the highest degree of flexibility primarily because of their structural simplicity. The two-region cases of options 4 and 7 rate somewhat lower. Option 1, where the two separate networks are maintained, also rates lower than options 2 and 3 because of differences in hardware and software between the Phoenix and Washington, D. C. installations in that option. Flexibility ratings continue to decrease as the number of regions increases, primarily because of increased complexity in realizing hardware and software changes.

2. Ease of Implementation

Option 1 received the highest rating for ease of implementation because the networks are already in existence. The two-region network of option 4 rates next on the ease of implementation scale, followed by the single-region cases of options 2 and 3.

Option 7, the two-region case with satellite capability rates fifth, and the multiple-region options follow in the order of their increasing number of switcher sites.

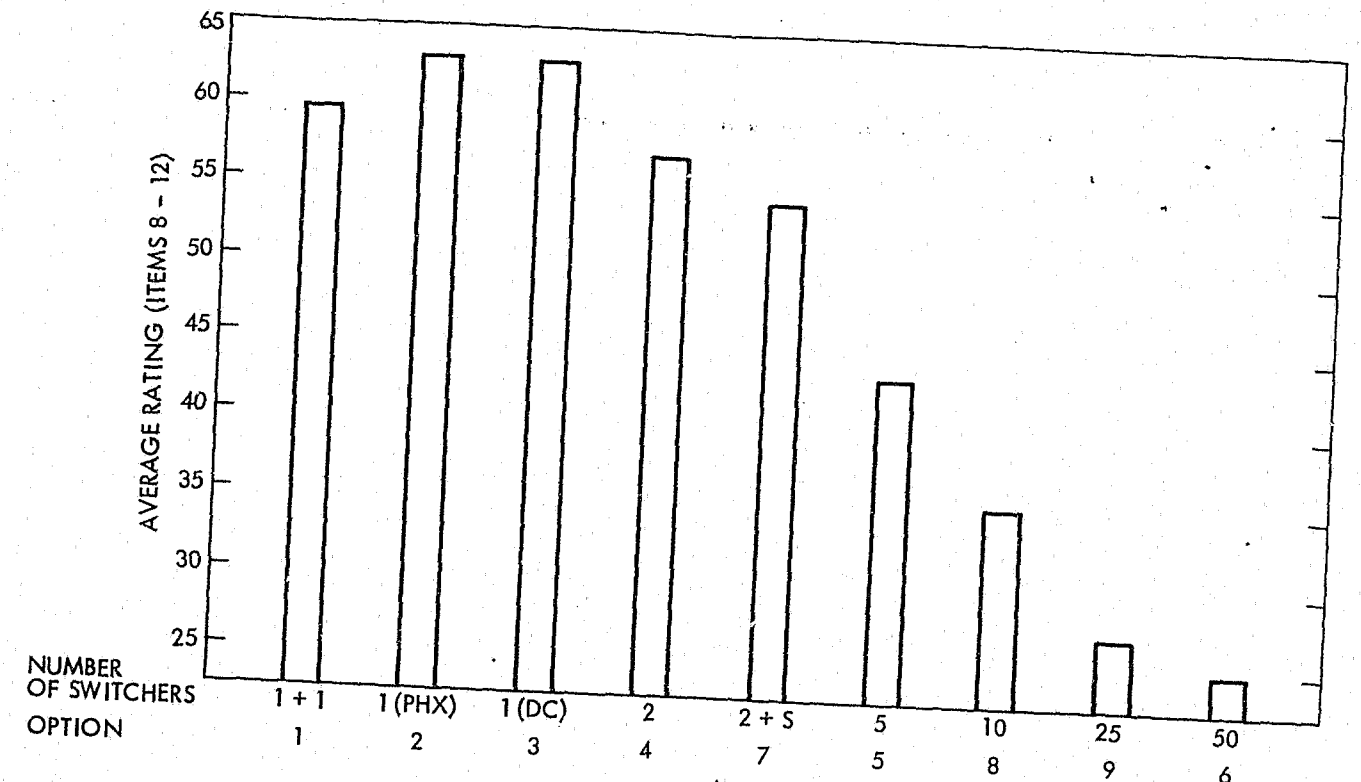

Fig. 36. Evaluation summary

3. Simplicity

The single-region configurations of options 2 and 3 received the highest rating for network simplicity. Principal reasons for this lie in their simple designs, network control, message routing simplicity, and ease in network checkout and monitoring functions.

As network checkout, operations, and maintenance are slightly more complex for the two-region case of option 4 compared with option 1, option 1 is rated second and option 4 third.

Option 7, involving video upgrade of a two-region configuration follows next. The multiple-region networks involving 5, 10, 25, and 50 switchers (options 5, 8, 9, and 6, respectively) logically follow with decreasing simplicity ratings.

4. Privacy

Ease in the maintenance of privacy received equally high ratings for the two single-region cases of options 2 and 3, and the two-region case of option 4. Option 1 was rated next due to the independent operational aspect of separate state and national networks.

Option 7 was next. Its two-region configuration is similar to option 4, but the use of satellite data links somewhat degraded the privacy rating.

The multiple-region networks received poor privacy ratings primarily because of increased difficulties in maintaining privacy with a large number of switchers as well as difficulty in accommodating possible legislative changes affecting privacy standards.

5. Security

The single-region cases of options 2 and 3 were rated highest with regard to network security. Single-region configurations are physically easier to guard against access by unauthorized personnel and against acts of violence. Message intercept protection is also easier when only one switcher is involved.

The two-switcher configurations of options 1, 4, and 7 received second-place security ratings of equal value for reasons similar to those mentioned.

Despite the fact that physical acts of violence can seriously degrade network operations of one- and two-switcher networks, the multiple-region networks received lower ratings primarily because of increased costs in maintaining security and the higher probability of network access by unwanted persons with a larger number of switchers in operation.

E. REQUIRED NETWORK SELECTION DATE

For all options, schedules and costs presented in this document assume a network decision to implement by January 1975.

This date is predicated on the assumption that a 2-year lead time is required to perform design, procurement, and installation of hardware. Thus, a decision date of January 1975 is required to provide an operational start date of January 1977.

Figure 37 illustrates the predicted growth of national (state-to-national plus national-to-state) traffic for both the best- and minimum-traffic estimates. The points plotted for 1975 assume 52,000,000 transactions per year and an average of 160 characters per transaction. Other points shown are derived from Appendix A. If the assumption is made that the NCIC can accommodate a doubling of present traffic before a major system redesign, upgrades would be required as follows:

Traffic model	Required upgrade date (operational)	Design start date ^a
Best estimate	Feb 1977	Feb 1975
Minimum estimate	Oct 1977	Oct 1975

^aAssuming 2-year design/implementation period.

A detailed analysis of the NCIC to determine the required upgrade date was not a part of this study.

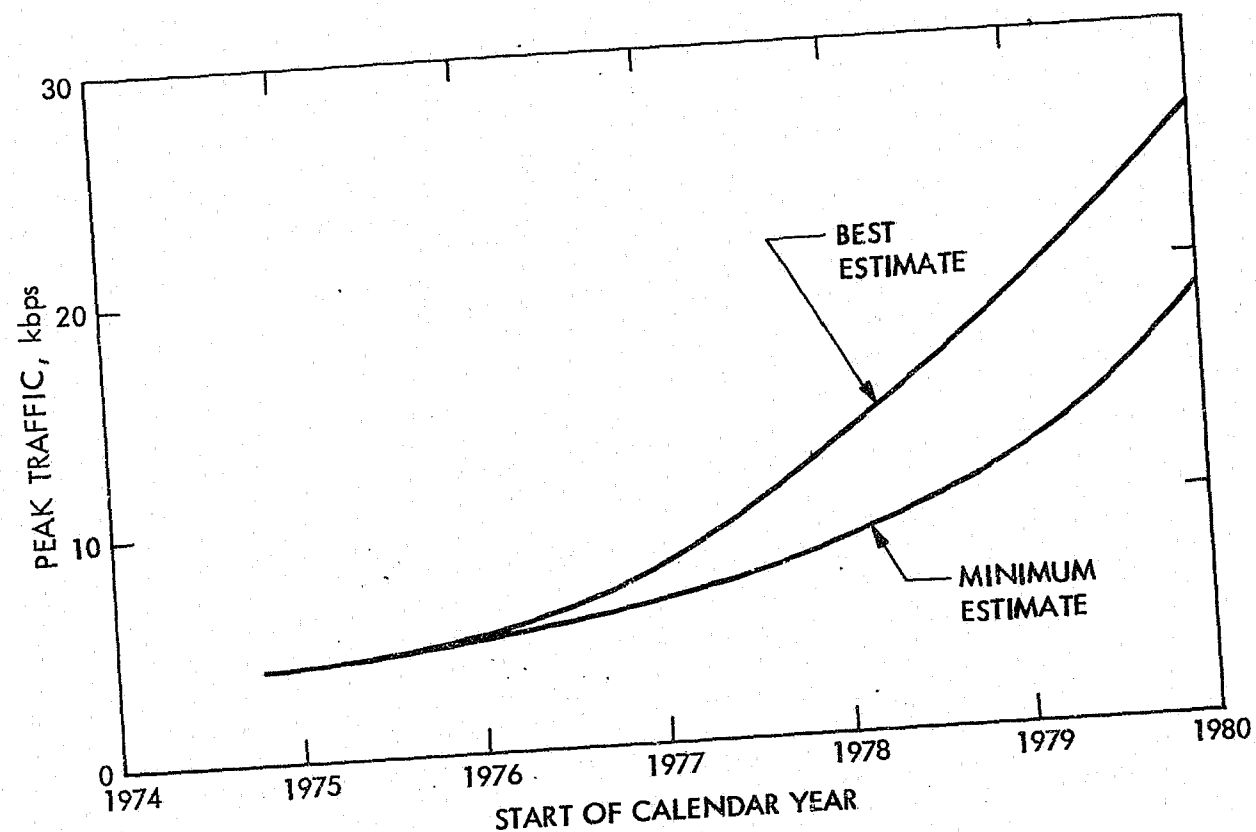

Fig. 37. National traffic projections

The NLETS switcher in its present configuration can handle traffic projections through January 1978 (see Fig. 38). The 2-year lead time requirement necessitates a decision date of January 1976 based on NLETS.¹

Also of note is the fact that a lack of decision is essentially a selection of option 1, as option 1 is really nothing more than continuing the two networks currently in existence (NCIC and NLETS).

F. MINIMUM TRAFFIC ANALYSIS

A minimum-traffic estimate was made to determine network costing sensitivity to reductions in projected traffic. Minimum-traffic levels were derived from the best-estimate projections by considering factors that may

¹ Background analysis of NLETS performance is contained in a JPL Interoffice Memorandum from D. Gallop to G. Garrison, October 1974.

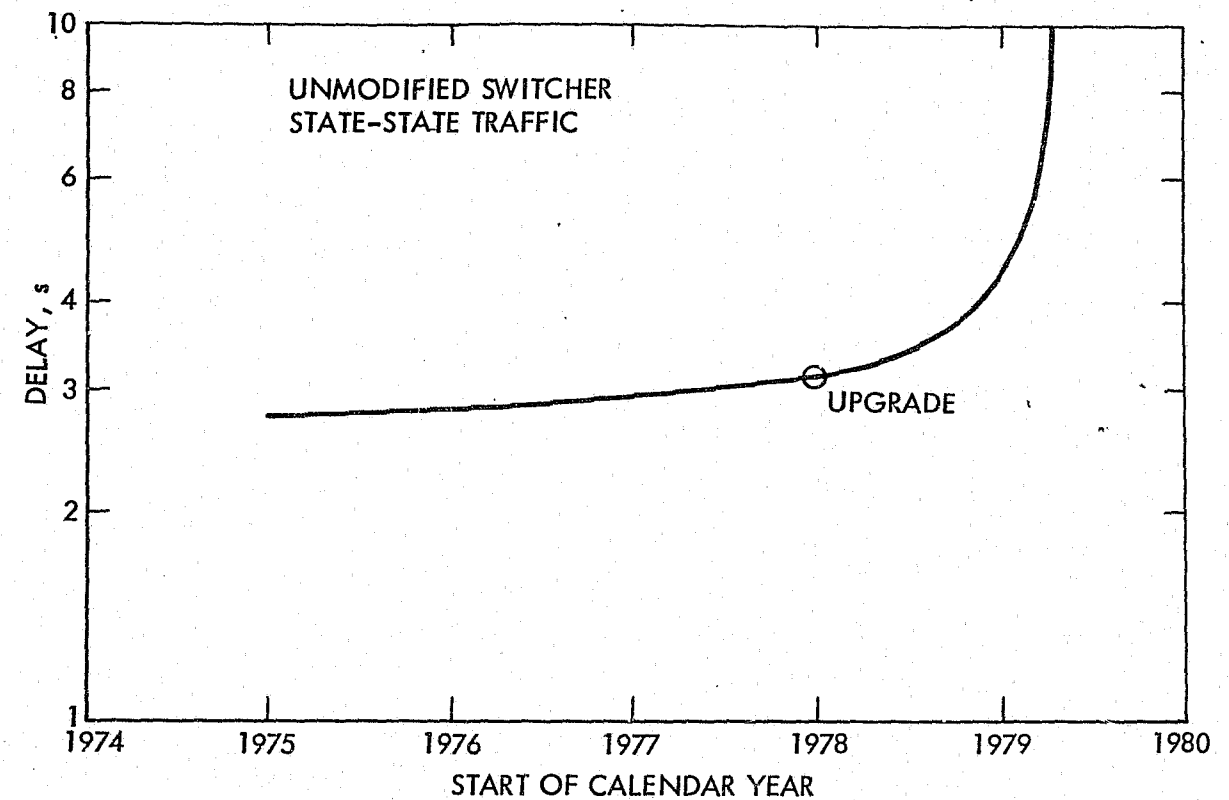

Fig. 38. NLETS delay estimates

reduce message lengths while maintaining predicted volume. Assumptions were made regarding the handling of CCH files and the characters per message of state-to-state mobile digital terminal traffic. Details of the derivation are presented in Appendix A. The result is shown in Table 11, which compares best-estimate and MDT levels for 1979 and 1983 in kilobits per second. The normal factor of 2 for peak vs average loading is not included in these figures.

Network costing with minimum traffic levels was conducted for options 3 (one switcher in D.C.) and 4 (two switchers). Reduction in traffic has the maximum effect with a small number of regions. Decreasing traffic principally impacts line assignments so that costs for lines and computer interfaces are lowered.

Table 12 shows changes in percent in total 7-year network costs for options 3 and 4 at minimum traffic levels. Cost differences amount to 1.8% and 4.0% for options 3 and 4, respectively. The conclusion is that total network costing is relatively insensitive to reductions in traffic levels.

Table 11. Best and minimum estimates: total traffic comparison
(values in kilobits per second)

Estimate	End of calendar year				
	1975	1977	1979	1981	1983
Best	3.3	7.7	16.2	26.0	34.7
Minimum	3.3	6.2	12.1	20.9	28.6

Table 12. Sensitivity of cost to traffic

Option	Number of switchers	Cost, dollars		Cost delta, %
		For best peak traffic (estimate)	For minimum peak traffic (estimate)	
3 ^a	1	8,200,000	8,100,000	-1.8
4	2	8,200,000	7,900,000	-4.0

^aComparisons made without multiplexing.

G. NLETS VS NALECOM PROTOCOL COMPARISON

NLETS protocol can be upgraded by the addition of two features that enable a system termination to gain control of the line when it has a high-priority message to send. Thus, upgraded protocol is referred to as the NALECOM protocol.

A comparison of NLETS vs NALECOM protocol was made to determine the relative advantages of each approach. The following summarizes protocol differences and comparison findings.

a. NLETS protocol. In the NLETS protocol the regional switcher behaves as a master in that it outputs all messages destined for a particular system termination before allowing any message inputs from that system

termination. Three priorities are used, but all priority messages to be output from the switcher have priority over messages generated at system terminations.

All message transmissions are self-contained in that they are initiated by a request for the line (ENQ) and terminated by an end of transmission (EOT). When line contention takes place, the switcher (or master) takes control of the line. This is basically the same protocol used by the NCIC and NLETS at present except that the three priority levels are not used.

b. NALECOM protocol. In the NALECOM protocol the regional switcher also behaves as a master. However, there are two modes of operation added that enable the system termination to gain control of the line when it has high-priority messages waiting to be transmitted.

The informal mode allows the system termination to immediately send a priority 1 message in place of an acknowledgement (ACK).

The second mode is the reverse interrupt mode (RVI), which notifies the regional switcher that the system termination has a priority 2 message in queue. Line control is relinquished by the regional switcher in this case when all priority one or two messages in the switcher queue have been sent.

These features allow the network to move high-priority messages in both directions in a more efficient manner. For a more detailed discussion of the proposed NALECOM protocol see Ref. 3.

c. Protocol comparison. Figures 39 and 40 show average delays for messages of priorities 1, 2, and 3 as a function of traffic for the two protocols over distances of 500 and 1000 mi, respectively.

The average delay is somewhat improved with the NALECOM protocol, but the improvement is not overly pronounced. The averages, however, do not show the periodic excessive waiting times that are encountered by system terminations under NLETS protocol when the regional switcher is outputting a long message to the system termination. Long messages are typically priority 3, and in these instances when the system termination has a priority 1 in queue the advantage of the NALECOM protocol becomes important.

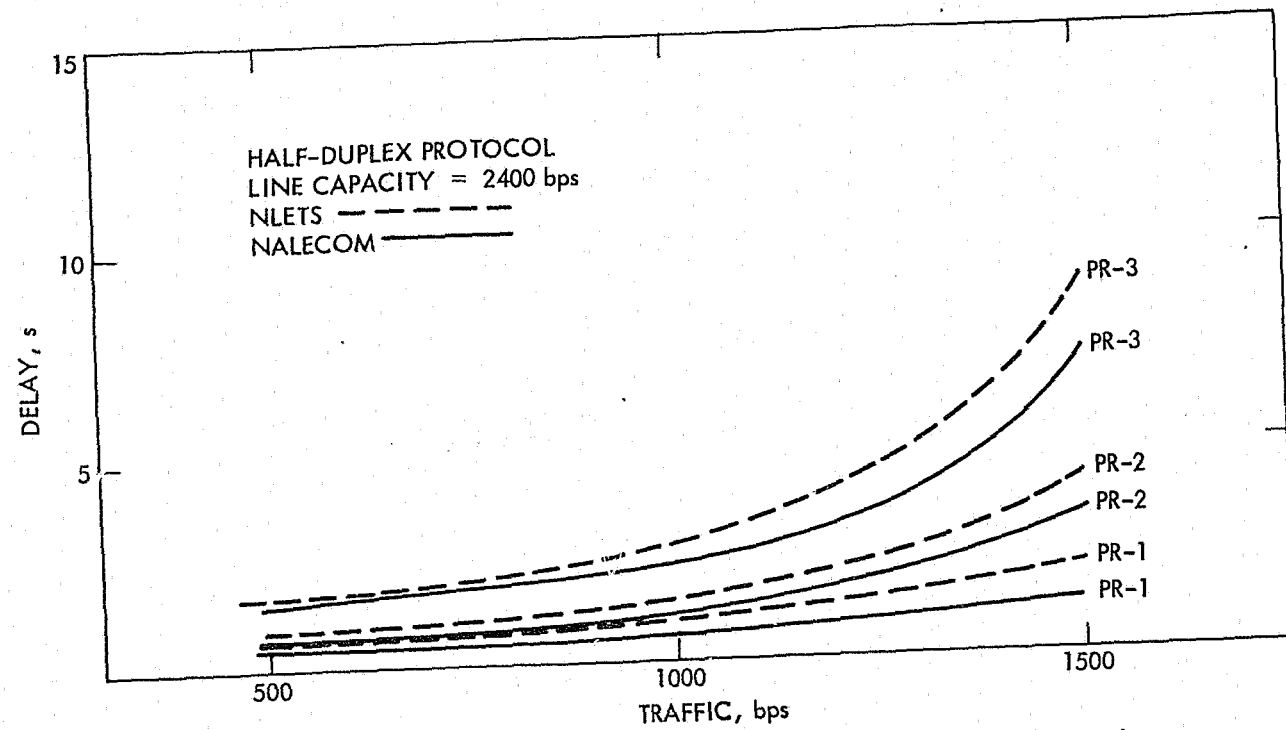

Fig. 39. NLETS vs NALECOM: state-to-region delay, 500 mi

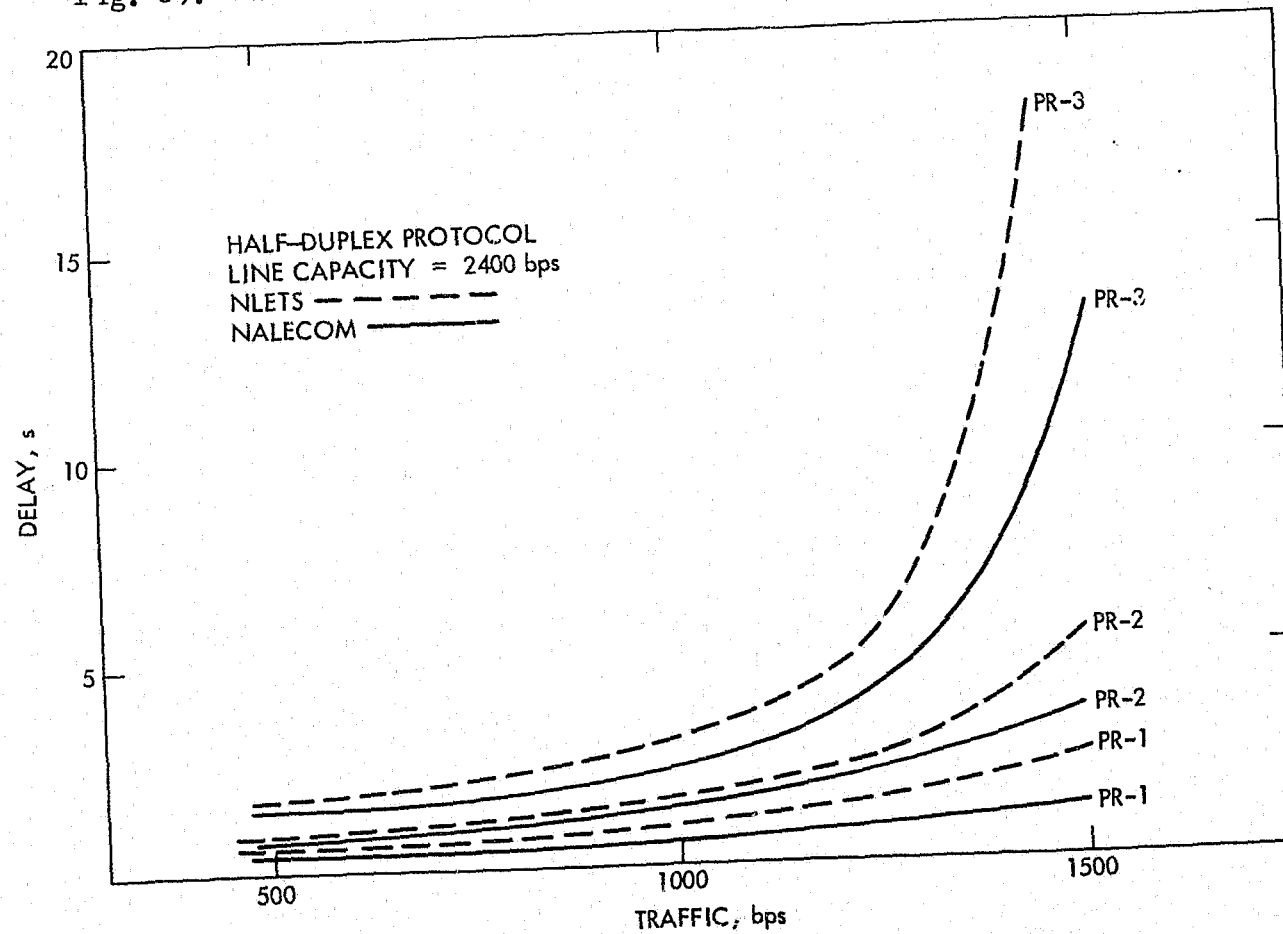

Fig. 40. NLETS vs NALECOM: state-to-region delay, 1000 mi

H. LEASE VS BUY POLICY

1. Modems

The policy used in the network design was to lease modems.

Figure 41 indicates the present modem lease-vs-buy crossover range for 2400-, 4800-, 7200- and 9600-bps modems. The shaded range of decision points represents vendor cost variations. The figure shows that it is cheaper to buy modems if large quantities are required. However, there are other factors to consider in determining a policy. Among them are that a substantial upgrade is planned for NALECOM in 1979 and design flexibility is desirable in the event of unforeseen changes. It is feasible, for example, that digital services may become available at a cost benefit before the 7-year network plan has transpired. If modems had been procured previously, they would then be unusable. Tables 13 through 16 compare lease-vs-buy data for four modem speeds for three different manufacturers.

2. Computer Hardware

The policy used in network design was to buy computer hardware.

Purchase is cost effective if equipment usage is greater than 4 years. As the lifetime of the network is 7 years, it is clearly advantageous to purchase computer hardware. The planned network upgrade in 1979 does not affect computer usage since the same hardware is used through network life. All computer hardware is purchased at the start of network operation to circumvent possible inability to procure additional hardware when the upgrade is made.

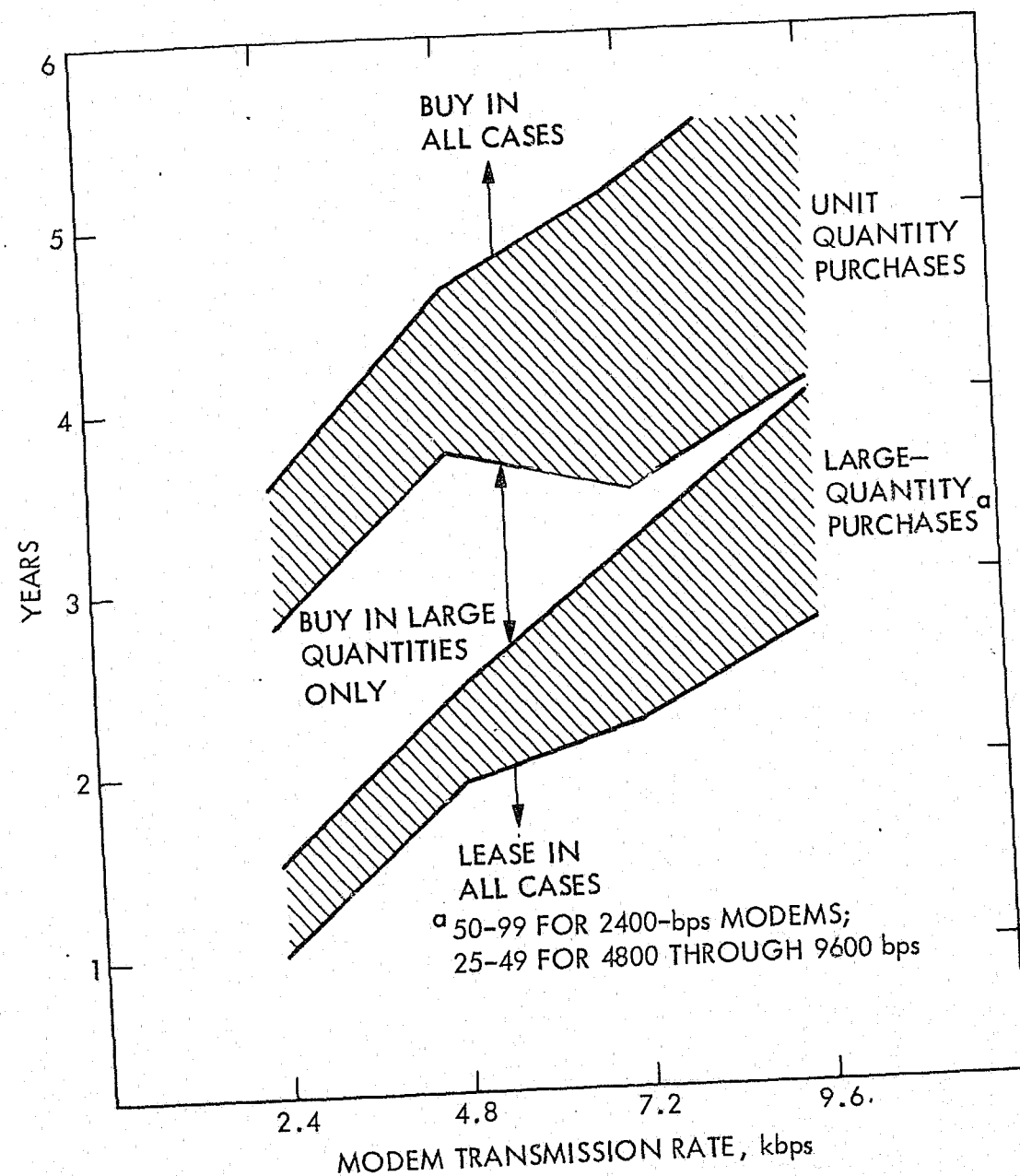

Fig. 41. Modem lease-vs-buy crossover range

Table 13. Lease-vs-buy tradeoff: 2400-bps modems

Modem	Purchase analysis cost, dollars ^a		Lease plus maintenance cost, dollars	
	3 years	7 years	3 years	7 years
Bell 201C	Not sold		1980	4620
GE 2201	1682 1246	2349 1879	1875	3027
ICC 24LSI	2064 1253	2884 1749	2050	2474

^aPurchase analysis includes list price, interest, maintenance, and residual value.

Note:

Unit Quantity	Large Quantity 25-49
---------------	-------------------------

Table 14. Lease-vs-buy tradeoff: 4800-bps modems

Modem	Purchase analysis cost, dollars		Lease plus maintenance cost, dollars	
	3 years	7 years	3 years	7 years
Bell 208A	Not sold		4500	10,500
ICC 4500/48	5776 3354	8067 4684	4090	9054
Penril 4800D	4872 4350	6804 6075	5994 5166	9030 8694

Note:

Unit Quantity	Large Quantity 25-49
---------------	-------------------------

Table 15. Lease-vs-buy tradeoff: 7200-bps modems

Modem	Purchase analysis cost, dollars		Lease plus maintenance cost, dollars	
	3 years	7 years	3 years	7 years
Bell 203	Not sold		7200	16,800
ICC 4800/72	8004 6252	11,316 8731	6234	11,944
CODEX 7200	8352 5916	11,664 8262	5580	-

Note:

Unit Quantity	Large Quantity 25-49
---------------	----------------------

Table 16. Lease-vs-buy tradeoff: 9600-bps modems

Modem	Purchase analysis cost, dollars		Lease plus maintenance cost, dollars	
	3 years	7 years	3 years	7 years
Bell 209	Not sold		8280	19,320
ICC 96A	11,588 9222	13,284 12,879	9459	18,977
CODEX 9600	11,310 8935	15,795 12,479	7200	-

Note

Unit Quantity	Large Quantity 25-49
---------------	----------------------

I. NCIC LOCATION ANALYSIS

An analysis was made to determine what cost savings could be realized by placing the NCIC (national data base) at a location other than Washington, D.C. Candidate locations were restricted to existing system terminations.

The topology program was run for seven mid-west locations from Ohio to Nebraska to determine the least cost location for the NCIC. In each case the cost of a 4800-bps line was included from the candidate system termination to Washington, D.C., to maintain communications with the FBI offices. A single-region topology was chosen for the comparison test, and results compared with the single-region case of option 3 where a single switcher (and the NCIC) is located in Washington, D.C.

The optimal location on a cost basis for the NCIC was found to be Springfield, Illinois. The 7-year total cost saving for this case is approximately \$500,000, compared with a national data base location at Washington, D.C.

Costs of moving NCIC equipment and personnel and opening new facilities would substantially reduce these savings to a small percentage of the total network cost. Consequently, the relocation of the NCIC was not considered in the costing of any of the options.

SECTION VII
CONCLUSIONS

The following conclusions summarize the salient findings discussed in Section VI. Presented here are general conclusions, rankings by evaluation criteria, and network selection conclusions.

A. GENERAL CONCLUSIONS

- Continuation of the two-network operation of option 1 will entail costs for 7 years greater than \$4,000,000 more than the lowest cost option.
- Advantages of highly distributed multi-region networks are outweighed by excessive costs, complexity, and problems related to security and privacy.
- Response-time goals for the NALECOM Network are met by all options considered.
- Reliability figures for all options are close to stated goals. Reliability can be improved to meet goals at moderate cost.
- Cost and schedule date given on options is predicated on a design start date of January 1975. This allows a 2-year engineering lead time before any of the options can become operational in January 1977.
- Projections indicate that the start on an NLETS upgrade is required by January 1976.

B. RANKING BY EVALUATION CRITERIA

1. Cost

The three least expensive options each have 7-year cost figures totalling less than \$10,000,000. They are:

Option 3 (one region, D. C.): \$8,000,000
Option 4 (two switchers): \$8,200,000
Option 5 (five switchers): \$9,500,000

Four options have 7-year total costs that range between \$10,000,000 and \$20,000,000. They are:

Option 2 (one region, Phoenix): \$10,100,000
Option 8 (ten switchers): \$11,700,000
Option 1 (separate networks): \$12,200,000
Option 9 (25 switchers): \$16,000,000

Two options exceed 7-year total costs of \$20,000,000:

Option 6 (50 switchers): \$25,000,000
Option 7 (two switchers/satellites): \$34,500,000

Option 7, phase 7-a costs are essentially those of option 4 with the addition of sufficient computer interface to enable eventual upgrading to phase 7-b. This addition to the option 4 cost is \$114,000. Phase 7-a costs are therefore approximately \$8,200,000.

If the National Data Base were not constrained to be located in Washington, D. C., the 7-year cost for a one-region configuration would be \$7,500,000 with the switcher optimally located in Springfield, Illinois.

2. Rating by Technical Evaluation Criteria

The five top options, based on the averages of five technical evaluation criteria, are rated as:

Options 2 and 3 (one region, Phoenix and one region, D.C.): 63
Option 1 (separate networks): 59
Option 4 (two switchers): 57
Option 7 (two switchers/satellites): 54

The other four options had technical evaluation ratings of less than 43.

C. NETWORK SELECTION

Only options 3 and 4 appear among the upper rankings of cost and technical evaluation criteria.

Considering cost and technical factors alone, option 3 is the best network choice.

Non-technical evaluation criteria (see Section IV-C) were not considered in this study. These factors may have a major impact on network selection, as several other options have technical rankings only slightly below option 3 and are of comparable cost.

APPENDIX A
TRAFFIC REQUIREMENTS

I. INTRODUCTION

This Appendix presents NALECOM traffic projections by year from 1975 through 1983, including a best estimate and a minimum estimate. Reference 2 was used as the basic source of data for traffic estimates with minor revisions in state-to-state projections to account for message lengths higher than anticipated.

The best-estimate projection assumes that the national computerized criminal history (CCH) files will contain pointers to state CCH files, which will be the primary repositories for such information, plus multi-state offender files. The minimum-estimate projection reduces the national CCH file to pointer information only; it also reduces state-to-state message lengths in anticipation of significant traffic buildup from mobile digital terminals (MDT). Message volume is essentially unaffected by these changes, but the data rate (in bits per second) is reduced by about 18% in 1983.

Message-length distributions are presented to show the relative volumes of short vs long messages, which relate in turn to the relative frequency of high- vs low-priority messages.

Traffic projections for MDTs were taken from Ref. 2. A preliminary field survey of several systems recently placed in operation has been conducted (see Section V of this Appendix). Results indicate that the projected increase in traffic due to the use of MDTs is verified by operational experience, and that the estimates need not be revised. Traffic actuals should be monitored frequently, however, to verify predicted trends.

II. BEST ESTIMATE

A. 1983 Traffic

Table A-1 presents the 1983 traffic estimates. With the exception of state-to-state traffic, which has been adjusted to reflect the relatively higher

Table A-1. Summary of NALECOM traffic projections for 1983^a (best estimate)

Item	State-to-State 1983			National 1983			1983 (total bps, averaged)
	Message volume, 10 ⁶ /year	Average characters/ message	Average bps	Message volume, 10 ⁶ /year	Average characters/ message	Average bps	
Current uses projected (includes MDT)	38.3	104	1,013	520.6	50	6,612	23,092
Inquiries } MDT	38.3	377	3,670	520.5	85	11,240	(66.5%)
Responses } MDT							
Messages from non-MDT	7.7	286	557				
Computerized Criminal Histories (Case II) ^b							
CH: Inquiries	0	N/A		11.2	70	199	
CH: Hit responses	N/A	N/A		9.1	1,725	3,987	5,589
CS: Inquiries	2.1	130	69	7.5	70	133	(16.1%)
CS: Hit responses	2.1	450	240	3.4	390	337	
No-Hit responses	N/A ^c	N/A		4.1	70	73	
Updates	N/A	N/A		7.9	256	514	
Pointer-hit responses	N/A	N/A		2.1	70	37	
Fingerprints							
Booked offenders				2,915	50,000 bits	4,624	4,664
Latent fingerprints				0.083	15,000 bits	40	(13.4%)
Criminal justice planners							
GMIS: Inquiries				0.060	70	1.06	63
GMIS: Responses				0.060	1,725	26.16	(0.2%)
NCJSDB: Inquiries				0.156	50	1.94	
NCJSDB: Responses				0.156	500	19.76	
NCJRS: Inquiries				0.052	50	0.68	
NCJRS: Responses				0.052	1,000	13.18	
Criminal intelligence information							
Administration				0.165	200	8.4	11
Inquiries				0.024	60	0.4	(<0.1%)
Responses				0.024	342	2.1	
Updates				0.01	1,000	0.1	
Crime labs							
Facsimile	0.0078	30,000	595	0.0078	300,000	595	1,310
Bibliographic data							
Inquiries				0.1095	60	1.7	(3.8%)
Responses				0.1095	2,500	69.5	
Firearms identification:							
Inquiries				0.1095	60	1.7	
Responses				0.1095	500	13.9	
Spectrographic data							
Inquiries				0.021	100	0.5	
Responses				0.021	700	3.6	
Administrative responses				0.2707	432	29.7	
Total bps (Averaged)			6,144 (17.7%)			28,585 (82.3%)	34,729

^aUses for courts, prosecution, and corrections have been accounted for under the estimates for computerized criminal history, criminal justice planners, and current uses projected.

^bNational pointer plus multi-state offenders. (CH refers to criminal history and CS to criminal summary.)

^cNot applicable.

character counts per message being reported by NLETS, the values are taken from Ref. 2. The resulting overall traffic volume is 8% higher than originally reported.

B. 1975-1983 Traffic

Each of the six categories of traffic listed in Table A-1 was extended over the time span of interest, 1975-1983, using the methods described in Chapters 6 and 7 of Ref. 2. The exceptions are:

- 1) The state-to-state current uses projected category was corrected to the actual traffic level experienced through 1973, when the NLETS system upgrade was placed in operation. Message volume level was reduced by about one-third, but bit rate was increased as noted.
- 2) The fingerprint and CCH categories were adjusted for an exponential buildup in usage over a 4-year period rather than a complete buildup in 1 year. CCH traffic was assumed to start in early 1976 and reach full-scale use by early 1980. Fingerprint traffic reaches full-scale use by early 1983. Traffic in both categories increases beyond these dates in proportion to increases in arrest rates (3.75% per year). The form of the exponential buildup is:

$$TRAF_i = TRAF_o \left(\frac{1 - e^{-\tau_i}}{1 - e^{-\tau_o}} \right)^3$$

where subscripts i and o refer to an arbitrary year and the final year, respectively. Values for the exponential term are:

End of year	$\left[\frac{1 - e^{-\tau_i}}{1 - e^{-\tau_o}} \right]^3$
1	0.122
2	0.453
3	0.773
4	1.000

C. Traffic Projection Summaries

Traffic projection summaries are presented in Tables A-2 and A-3 for the time period 1975-1983 for national-state and state-state messages, respectively. The message and kilobit-per-second volumes are shown for each category of traffic, as defined in Table A-1. The results are approximately the same as those given in Ref. 2, assuming a gradual buildup in both CCH and fingerprint usage.

III. MINIMUM ESTIMATE

Two changes were made in the best-estimate projections to derive a minimum estimate:

- 1) CCH system was reduced to a national pointer system with all CCH files retained by the cognizant states (Case III in Ref. 2).
- 2) A lower value was assumed for the number of characters per message for the state-to-state MDT traffic. (The value was reduced from 377 to 150 characters per message to make it more consistent with values measured on the NCIC network.)

These two changes have the effect of reducing the bit rate (kbps) by about 18%, but not altering the message volume. The results are presented in Tables A-4 and A-5.

IV. MESSAGE-LENGTH DISTRIBUTIONS

Message-length distributions for the above traffic projections are given in Tables A-6 and A-7 for state-national and state-state messages, respectively. Values shown do not always total exactly 100% because percentage values are rounded off to the nearest 1/10%.

V. VERIFICATION OF TRAFFIC ESTIMATES

Comparisons have been made between the foregoing traffic estimates and traffic actuals accumulated through November 1974. Admittedly the actuals do not extend beyond the 1973 base year by more than 10 to 12 months, but a significant set of new data has been obtained for MDT traffic,

Table A-2. State-national traffic projections (best estimate)

Item	1975		1977		1979		1981		1983	
	Mpy ^a	Kbps ^b	Mpy ^a	Kbps ^b	Mpy ^a	Kbps ^b	Mpy ^a	Kbps ^b	Mpy ^a	Kbps ^b
Current uses projected										
State-national	59.3	0.755	109.0	1.389	215.9	2.751	358.8	4.571	520.6	6.612
National-state	59.3	1.284	109.0	2.361	215.9	4.676	358.8	7.772	520.6	11.240
Computerized criminal history										
State-national	--	--	10.4	0.329	23.1	0.736	24.9	0.791	26.6	0.846
National-state	--	--	7.3	1.725	16.3	3.855	17.5	4.146	18.7	4.434
Fingerprints										
State-national	--	--	--	--	0.4	0.553	2.3	3.510	3.0	4.664
National-state	--	--	--	--	(Small)	(Small)	(Small)	(Small)	(Small)	(Small)
Criminal justice planners										
State-national	0.1	0.002	0.2	0.002	0.2	0.003	0.2	0.003	0.3	0.004
National-state	0.1	0.028	0.2	0.033	0.2	0.040	0.2	0.049	0.3	0.059
Criminal intelligence information										
State-national	(Small)	(Small)	(Small)	(Small)	(Small)	(Small)	(Small)	(Small)	(Small)	(Small)
National-state									0.2	0.010
Crime labs										
State-national	0.2	0.219	0.2	0.237	0.2	0.256	0.2	0.277	0.2	0.299
National-state	0.4	0.305	0.4	0.330	0.4	0.356	0.5	0.384	0.5	0.415
Total state-national	59.6	0.976	119.8	1.957	239.8	4.299	386.4	9.152	550.7	12.425
Total national-state	59.8	1.617	116.9	4.449	232.8	8.927	377.0	12.351	540.3	16.158

^aMillion messages per year.

^bKilobits per second.

Table A-3. State-state traffic projections (best estimate)

Item	1975		1977		1979		1981		1983	
	Mpy ^a	Kbps ^b	Mpy ^a	Kbps ^b	Mpy ^a	Kbps ^b	Mpy ^a	Kbps ^b	Mpy ^a	Kbps ^b
Current uses projected	9.6	0.694	17.7	1.208	35.0	2.264	57.9	3.646	84.3	5.240
Computerized criminal history	0	0	1.5	0.110	3.3	0.244	3.9	0.289	4.2	0.309
Crime labs	0	0	0	0	(Small)	0.436	(Small)	0.515	(Small)	0.595
Total	9.6	0.694	19.2	1.318	38.3	2.944	61.8	4.450	88.5	6.144

^aMillion messages per year.

^bKilobits per second.

Table A-4. State-national traffic projections (minimum estimate)

Item	1975		1977		1979		1981		1983	
	Mpy ^a	Kbps ^b	Mpy ^a	Kbps ^b	Mpy ^a	Kbps ^b	Mpy ^a	Kbps ^b	Mpy ^a	Kbps ^b
Current uses projected										
State-national	59.3	0.755	109.0	1.389	215.9	2.751	358.8	4.571	520.6	6.612
National-state	59.3	1.284	109.0	2.361	215.9	4.676	358.8	7.772	520.6	11.240
Computerized criminal history										
State-national	--	--	5.6	0.099	12.4	0.221	13.4	0.237	14.3	0.254
National-state	--	--	4.4	0.078	9.7	0.173	10.5	0.186	11.2	0.199
Fingerprints										
State-national	--	--	--	--	0.4	0.553	2.3	3.510	3.0	4.664
National-state	--	--	--	--	(Small)	(Small)	(Small)	(Small)	(Small)	(Small)
Criminal justice planners										
State-national	0.1	0.002	0.2	0.002	0.2	0.003	0.2	0.003	0.3	0.004
National-state	0.1	0.028	0.2	0.033	0.2	0.040	0.2	0.049	0.3	0.059
Criminal intelligence information										
State-national		(Small)	(Small)	(Small)	(Small)	(Small)	(Small)	(Small)	(Small)	(Small)
National-state									0.2	0.010
Crime labs										
State-national	0.2	0.219	0.2	0.237	0.2	0.256	0.2	0.277	0.2	0.299
National-state	0.4	0.305	0.4	0.330	0.4	0.356	0.5	0.384	0.5	0.415
Total state-national	59.6	0.976	115.0	1.727	229.1	3.784	374.9	8.598	538.4	11.833
Total national-state	59.8	1.617	114.0	2.802	226.2	5.245	370.0	8.391	532.8	11.923

^aMillion messages per year.

^bKilobits per second.

Table A-5. State-state traffic projections (minimum estimate)

Item	1975		1977		1979		1981		1983	
	Mpy ^a	Kbps ^b	Mpy ^a	Kbps ^b	Mpy ^a	Kbps ^b	Mpy ^a	Kbps ^b	Mpy ^a	Kbps ^b
Current uses projected	9.6	0.682	17.7	1.022	35.0	1.576	57.9	2.263	84.3	3.058
Computerized criminal history	0	0	4.0	0.455	8.9	1.019	9.5	1.097	10.2	1.173
Crime labs	0	0	0	0	(Small)	0.436	(Small)	0.515	(Small)	0.595
Total	9.6	0.682	21.7	1.477	43.9	3.031	67.4	3.875	94.5	4.826

^aMillion messages per year.

^bKilobits per second.

Table A-6. State-national message length distributions (best estimate)

Characters per message	State-national									
	1975		1977		1979		1981		1983	
	Mpy ^a	% Mpy ^a	Mpy ^a	% Mpy ^a	Mpy ^a	% Mpy ^a	Mpy ^a	% Mpy ^a	Mpy ^a	% Mpy ^a
50	59.4	99.5	109.2	91.0	216.1	90.0	259.0	92.9	520.8	94.5
60	0.2	0.3	0.2	0.2	0.2	0.1	0.2	0.1	0.2	0
70	0	0	7.3	6.1	16.2	6.8	17.5	4.5	18.7	3.4
256	0	0	3.1	2.6	6.9	2.9	7.4	1.9	7.9	1.4
50,000 bits ^b	0	0	0	0	0.4	0.2	2.2	0.6	2.9	0.5
15,000 bits ^b	0	0	0	0	0	0	0.1	~0	0.1	~0
300,000	0.003	0.005	0.003	0.003	0.003	0.001	0.004	0.001	0.004	0.001
Total	59.6	100	119.8	100	239.8	100	386.4	100	550.7	100
National-state										
70	0	0	2.4	2.1	5.4	2.3	5.8	1.5	6.2	1.1
85	59.4	99.2	109.0	93.2	215.9	92.7	358.8	95.2	520.6	96.4
200	0.1	0.1	0.1	0.1	0.1	0.1	0.1	0	0.2	0
390	0	0	1.3	1.1	3.0	1.3	3.2	0.8	3.4	0.6
500	0.1	0.1	0.1	0.1	0.1	0.1	0.1	0	0.2	0
1,725	0	0	3.6	3.0	7.9	3.4	8.5	2.3	9.1	1.7
300,000	0.003	0.005	0.003	0.003	0.003	0.001	0.004	0.001	0.004	0.001
Total	59.8	100	116.9	100	232.8	100	377.0	100	540.3	100

^aMillion messages per year.

^bBits per message.

Table A-7. State-state message length distributions

Characters per message	Best estimate									
	1975		1977		1979		1981		1983	
	Mpy ^a	% Mpy ^a	Mpy ^a	% Mpy ^a	Mpy ^a	% Mpy ^a	Mpy ^a	% Mpy ^a	Mpy ^a	% Mpy ^a
104	0.2	2.0	3.3	17.1	12.1	31.6	24.3	39.3	38.3	43.3
130	0	0	0.7	3.9	1.7	4.3	2.0	3.2	2.1	2.4
286	9.2	95.9	11.1	58.0	10.9	28.2	9.3	15.0	7.7	8.6
377	0.2	2.0	3.3	17.1	12.1	31.6	24.3	39.3	38.3	43.3
450	0	0	0.7	3.9	1.7	4.3	2.0	3.2	2.1	2.4
300,000	0	0	0	0	0.01	0	0.01	0	0.01	0
Total	9.6	100	19.2	100	38.3	100	61.9	100	88.5	100
Minimum estimate										
70	0	0	2.0	9.1	4.4	10.1			5.1	5.4
104	0.2	2.1	3.3	15.2	12.1	27.5			38.3	40.6
150	0.2	2.1	3.3	15.2	12.1	27.5			38.3	40.6
286	9.2	95.9	11.1	51.4	10.9	24.8			7.7	8.1
390	0	0	1.3	6.0	3.0	6.7			3.4	3.6
1,725	0	0	0.7	3.1	1.5	3.4			1.7	1.8
300,000	0	0	0	0	0.01	0			0.01	0
Total	9.6	100	21.6	100	43.9	100			94.5	100

^aMillion messages per year.

which contributes heavily to the anticipated growth in both inter-state and intra-state traffic in the late 1970s and beyond.

The following comparisons are presented in Figs. A-1 through A-3 and in Table A-8:

- a) State-national traffic: Fig. A-1
- b) State-state traffic (messages): Fig. A-2
- c) State-state traffic Fig. A-3
- d) MDT traffic: Table A-8

A. State-National Traffic

Figure A-1 compares the traffic estimates of Ref. 2 to NCIC actuals through October 1974; the 1974 actual was obtained by a seasonally adjusted extrapolation of year-to-date data. Results show a reasonable agreement between actual and estimated growth over the short period of overlap; growth rates are quite similar.

Note that NCIC traffic has increased 60% in the past 2 years, or about 30% per year. This is considerably greater than the unofficial estimate of 10 to 15% per year growth rate.

B. State-State Traffic

Figure A-2 compares the message traffic estimate of Ref. 2 with the NLETS actuals through November 1974. Traffic remained constant until the December 1973 switch upgrade, beyond which a sharp increase in traffic occurred. Good agreement is noted between the estimates and actuals to date.

A similar comparison is shown in Fig. A-3 for NLETS bit rates (in kilobits per second). Actual bits per message are considerably higher than values assumed used in Ref. 2; the estimates of Table A-1 are based on the higher values. Again, a good agreement is noted between the estimates and actuals. Traffic can be expected to increase at a fairly rapid rate as more user states install automated data base query capabilities, especially vehicle registration and driver's license files.

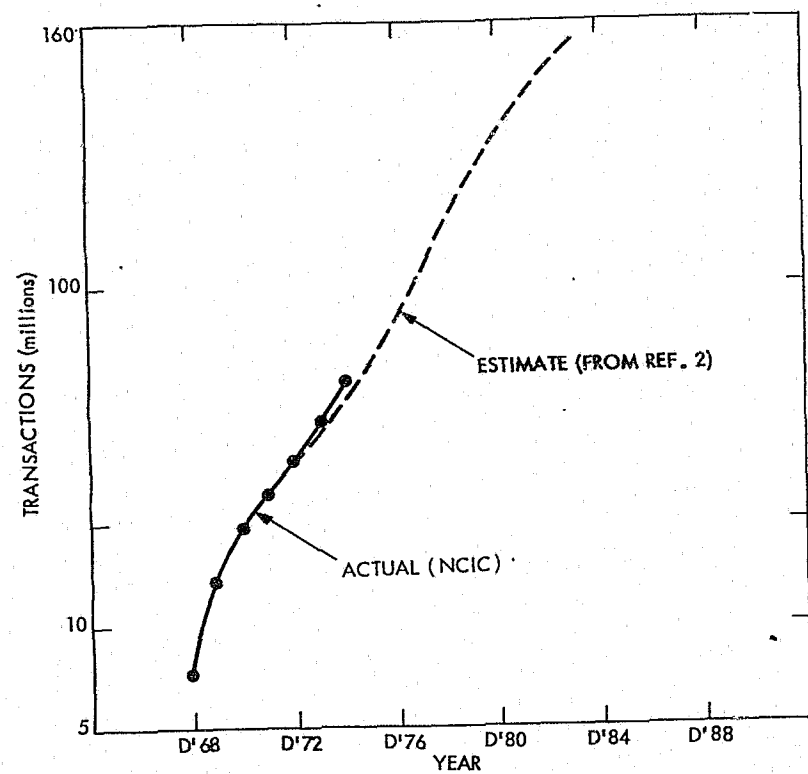

Fig. A-1. State-national traffic estimates: transactions

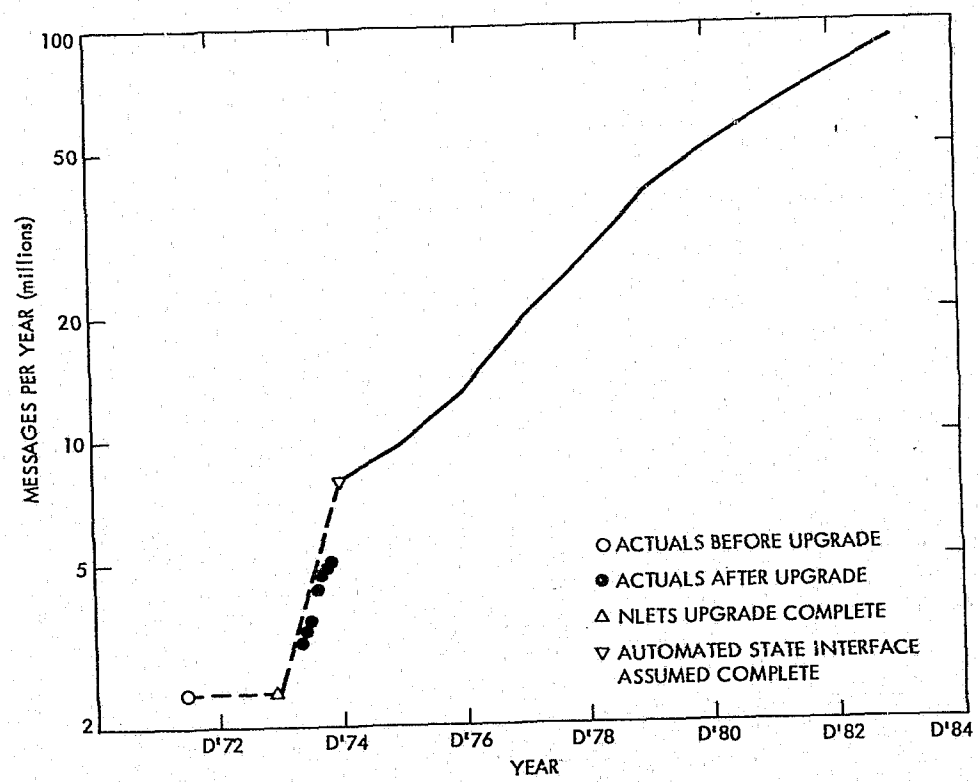

Fig. A-2. State-state traffic estimates: messages per year

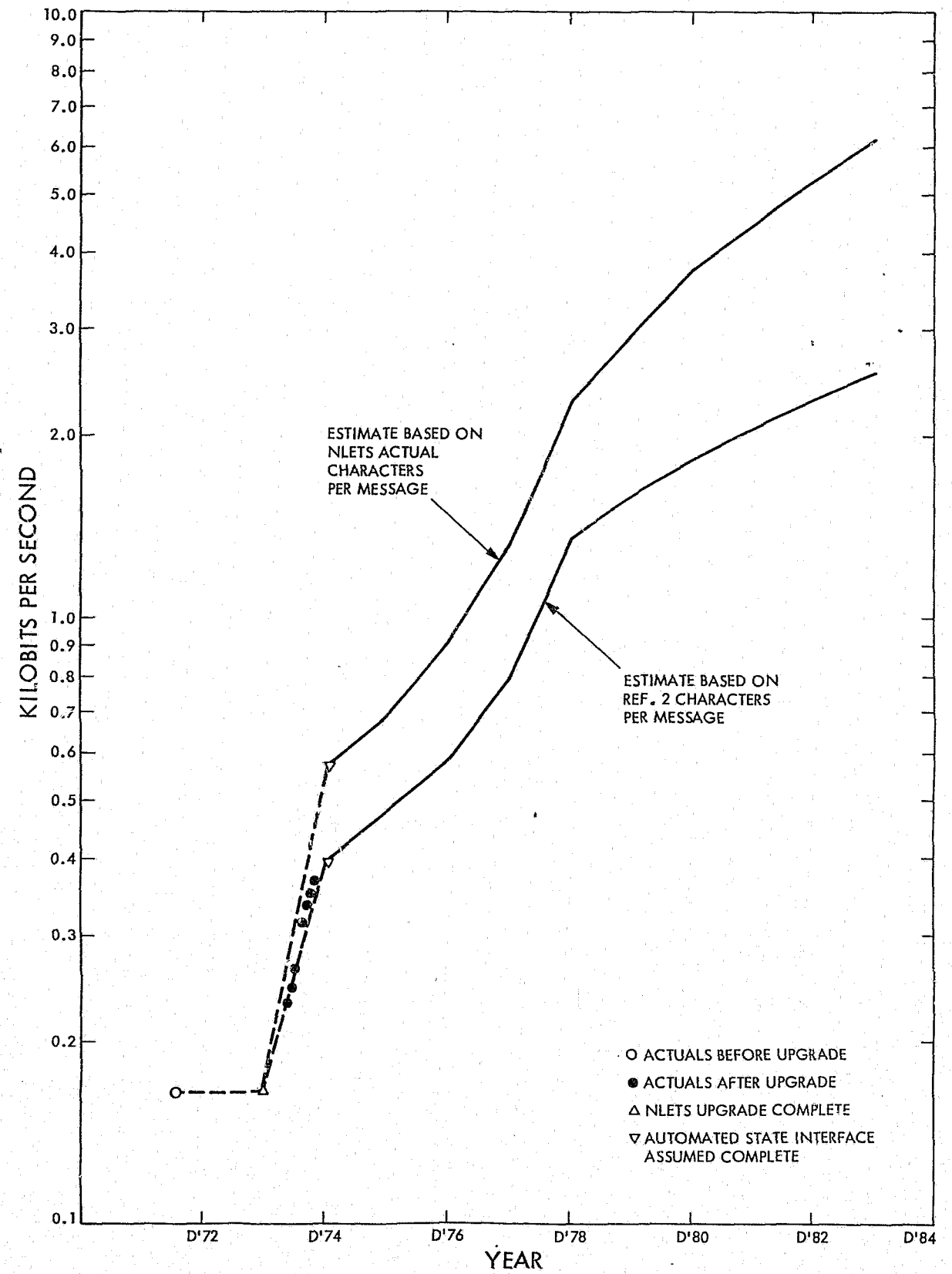

Fig. A-3. State-state traffic estimates

Table A-8. MDT traffic estimates

City	Population, thousands	Patrol units ^a	Population per unit	Automatic query	Number of MDTs	Queries per MDT /h	Queries to NCIC per MDT/h	Increases in queries with MDT
Kansas City	503	150	3353	Yes	14	4.8	0.75	×4.5
Oakland	360	45	8000	Yes	25	2.0	0.2	×5
Palm Beach County Sheriff	150 ^b	36	4160	Yes	30	1.9	1.9	×10+
Cleveland	741	138	5370	Yes	40	6	6	×3.5
Minneapolis	435	45	9667	Yes	25	2	0.3	×10
Chicago ^c	3500	NA ^d	NA	Yes	NA	5.8	1.2	NA
San Francisco ^e	720	52	13846	Yes	5	NA	-	-
Glendale	135	19	7105	No	-	NA	-	-
Huntington Beach	150	25-50	4000(av)	No	-	0.4	-	-
Montclair	24	7	3429	No	-	NA	-	-
Seattle	525	200	2625	No	-	0.4	-	-
Average			6600			3.8(MDT)	1.7	6.6
(Ref. 2 assumptions)			(5550)				(1.5)	(5.0)

^aMaximum patrol units in field at any given time.

^bPopulation served by Palm Beach County Sheriff.

^c1974 test results.

^dNot available.

^eNot fully operational; data not available.

C. MDT Traffic

It is expected that MDT traffic will have a major impact on both inter-state and intra-state traffic in the next decade. To date, less than 1% of the mobile patrol units are equipped with MDTs, but these few operational units show a marked increase in data base queries compared to query rate over conventional voice links.

To verify the traffic estimates of Ref. 2, a limited survey was conducted of several agencies that have equipped a number of their patrol units with MDTs. (Only one or two agencies surveyed have equipped all patrol units with MDTs to date, although it is their intention to do so in the near future.) Eleven agencies were visited, six of which have automated data base query capability through MDTs; other agencies were surveyed because of their experience with computer-aided dispatch systems or automatic vehicle location systems. The results of the survey are summarized in Table A-8.

Key factors obtained from the survey include:

- 1) Increase in data base queries from MDTs vs queries over voice links.
- 2) Number of patrol units per capita.
- 3) Number of data base queries from MDTs per unit per hour.
- 4) Fraction of queries directed to NCIC or NLETS.

Factors (1) and (2) can be combined as shown in Ref. 2, Pages 6-29, to derive an estimate for total MDT originated traffic, assuming widespread use by all agencies by 1983. The actual increase in query rates with MDTs is noted to be 6.7, compared with an estimate of 5.0 used in Ref. 2. Samples and estimated number of patrol units per capita are 6600 and 5550, respectively; i.e., the estimated number of patrol units is somewhat higher than the sample actual. The actuals for factors (1) and (2) are sufficiently close to the estimates that revisions are not warranted at this time. Essentially, the anticipated increase in data base query rates is confirmed by operational experience to date.

A second comparison of actuals with estimates can be obtained by using factors (2) and (4) directly to derive the absolute number of queries directed to NCIC or NLETS. Again, the actuals confirm the estimates within reasonable limits.

Several observations can be made regarding MDT traffic estimates. The use of MDTs in the law enforcement community is in its infancy; less than 1% of the total patrol fleet¹ is equipped with these devices, and operational experience is limited to less than 1 year in most cases. About 2 to 3% of the total patrol fleet will be so equipped by the end of 1975. Traffic projections through 1983 based on available actuals must be reviewed frequently to verify projected trends.

A wide variance in use rates is noted in Table A-8, from 1.9 to 6 queries per MDT per hour. Many factors contribute to this variance, and it is premature to construct multivariate traffic models based on the limited data available. As use of MDTs becomes more widespread, correlations should be attempted with variables such as: (1) number of calls for service, (2) patrol units per capita, (3) crime rate, (4) use of one-man versus two-man patrols, and (5) agency policies regulating the conditions under which data base queries should be made. One might expect a strong dependence on patrol units per capita and crime rate, and relatively weak dependence on total population. The variation in query rate between one-man and two-man patrols is difficult to predict; also, the variation in query rates between busy and slack periods is obscured by conflicting demands on the officers' time.

A significant factor not previously quantified relates to an agency's policy of limiting queries to local or state data files, or directing all queries to the NCIC as well as local and state files. The Cleveland Police Department and Palm Beach County Sheriff's Office follow the latter policy, while the other agencies interviewed restricted NCIC queries to wanted-person and out-of-state-vehicle checks, which constitute about 10 to 20% of the total traffic. It can be expected that agencies will alter their policies in response to developments in query capability (and demand). For example, if query rates increase to the point of saturating communication links to data files, an agency would be forced to implement more restrictive query policies until additional communication capability was installed. Low hit rates might also induce an agency to

¹The total potential number of MDT installations is estimated at 37,500 (see Ref. 2, Pages 6-29).

limit queries. On the other hand, a capability to automatically run a check on a registered owner simultaneously with a vehicle check would greatly increase transactions against the NCIC wanted-person file. This capability is now available on a limited basis, but is used extensively because of enhanced officer safety.

In summary, the results of the survey indicate that automated queries from MDTs is one of the most readily accepted and utilized innovations in law enforcement command and control, and can be expected to rapidly increase data base query traffic over the next decade. Small and large communities will be afforded this capability through metropolitan and regional systems (e.g., Kansas City and Las Vegas) and county-wide cooperative systems (e.g., Palm Beach County).

APPENDIX B
COMMUNICATION LINE COSTS

I. INTRODUCTION

This Appendix presents a detailed description of costs for communication lines within the continental United States (CONUS) and for links to Alaska and Hawaii.

A typical communication line structure between a system termination point and a regional switcher is shown in Fig. B-1. The line consists of a modem at each end, each of which is connected locally to a service terminal where the long-distance connection is made between the cities being served. The communication line is subject to a mileage charge.

This Appendix covers line mileage costs (which include service terminal costs), modem costs, special costs to Alaska and Hawaii, and multiplexing costs. Sample calculations are included.

II. LINE MILEAGE COSTS

Line mileage costs cover costs of connecting voice grade lines from one modem to another. These include the local service terminal cost at both ends plus the charge based on airline mileage distances between the cities being serviced. (The service terminal cost is the charge for connecting a line from the actual user's site to a local exchange office for long-distance transmission.) Table B-1 shows installation and monthly charges for these services by line capacity.

III. MODEM COSTS

Modems provide the essential interface between a terminal (system termination, regional switcher, etc.) and a communication line. They provide the translation between the digital signals used by terminals and the analog signals transmitted over communication lines.

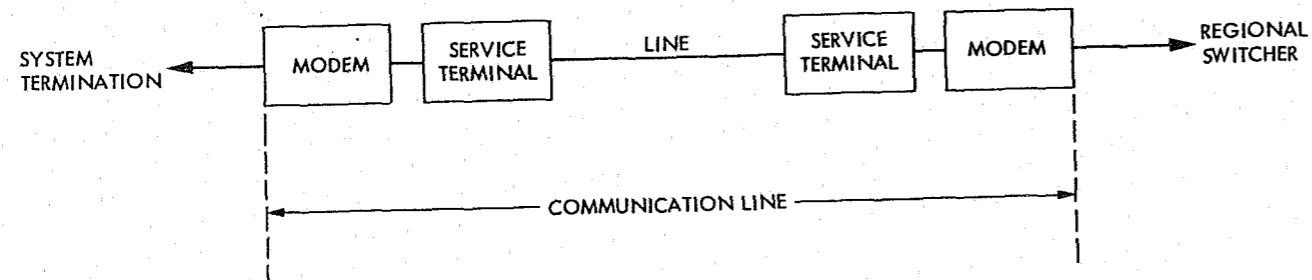

Fig. B-1. Components of a typical communication line

Table B-1. Line mileage and service terminal costs

Line data rate, bps	Line cost, dollars per month per mile	Service terminal costs, dollars	
		Installation	Maintenance per month
2400	0.54	50.00	40.00
4800	0.54	50.00	40.00
7200	0.54	50.00	40.00
9600	0.54	50.00	40.00
50,000	6.48	200.00	425.00

Standard voice grade telephone lines are unconditioned, meaning that they meet minimum specified line requirements. Special engineering, or conditioning, by the phone company is required to maintain performance of voice grade lines operating at higher bit-per-second capacities. The Bell Telephone Company uses the term "data set" to mean modem. Installation and monthly costs for leased Bell Telephone Company data sets, together with line conditioning costs where appropriate, are given in Table B-2. A sample calculation for a terrestrial 2400-bps communication line over a distance of 100 miles is given in Table B-3.

IV. ALASKA AND HAWAII LINKS

Alaska and Hawaii are serviced via international links from Seattle and San Francisco, respectively. Line costs to these states, therefore, include terrestrial line charges from the regional switcher(s) servicing the states of Washington and California plus the respective link costs outside the CONUS. Link costs for 2400-bps service are shown in Table B-4. Minimum 2400-bps service is provided to both Alaska and Hawaii in all options. A sample calculation for a 2400-bps line from a regional switcher in Phoenix to a system termination in Juneau is given in Table B-5.

V. LINE SIZING

The following sample calculation indicates how line capacity is adjusted in the topology program (see Section III of main report) to maintain a line utilization factor, or ρ , of less than 0.7. As stated in Section III, ρ is given by:

$$\rho = \left(\frac{T}{L_m \times B_c} \right) \left[\frac{(L_m + OH) B_c}{C} + NTA \times D \times DDL + NPT \right]$$

Table B-2. Modem and line conditioning costs

Line capacity, bps	Bell modem	Modem costs, ^a dollars		Line conditioning costs, ^a dollars	
		Installation per month	Maintenance per month	Installation per month	Maintenance per month
2,400	201C	75.00	55.00	-	-
4,800	208A	150.00	125.00	-	-
7,200	203	200.00	200.00	-	19.00
9,600	209A	200.00	230.00	150.00	13.50
50,000	-	<u>-^b</u>	<u>-^b</u>	-	-

^aRequired at both ends of line.

^bIncluded in service terminal costs.

Table B-3. Sample calculation

Item	Installation costs, dollars	Maintenance costs per month, dollars
2400-bps modems, Two required	150.00	110.00
Line conditioning	-	-
Service terminals, Two required	100.00	80.00
Mileage cost 100 miles at \$0.54/mile	-	54.00
Total installation	<u>250.00</u>	
Total monthly charge		244.00
Annual charge		<u>2,928.00</u>

Table B-4. 2400-bps international link costs

International link	Lease costs per month, dollars
Seattle-Juneau	2,278.75
San Francisco-Honolulu	5,200.00

Table B-5. Sample calculation

Item	Installation costs, dollars	Maintenance costs per month, dollars
2400-bps modems Two required	150.00	110.00
Line conditioning	-	-
Service terminals Two required	100.00	80.00
Mileage cost (CONUS) Phoenix to Seattle 1094 mi at \$0.54/mi	-	590.76
Seattle-Juneau International link	-	<u>2,278.75</u>
Total installation	<u>250.00</u>	
Total monthly charge		3,059.51
Total annual charge		<u>36,714.12</u>

Consider a communication line between Phoenix and Washington, D. C., with traffic level (T) equal to 1.32 kbps and a distance (D) of 1977 mi. Other values in the equation are:

L_m = average message length in characters = 118

B_c = bits/character = 8

OH = overhead characters or message characters other than actual text characters = 34

NTA = average number of line turnarounds required to complete a message = 5

D = distance from system termination to regional switcher, mi

DDL = line propagation delay in milliseconds/100 mi = 0.001 s

NTP = nodal processing time = 0.006 s

To begin the calculation, a line capacity (C) of 2400 bps is used.

$$\rho = \left(\frac{1320}{118 \times 8} \right) \left[\frac{(118 + 34) \times 8}{2400} + \frac{5 \times 1977 \times 0.001}{100} + 0.006 \right]$$

$$= (1.398)(0.507 + 0.1048)$$

$$= 0.854$$

The resulting value of ρ equal to 0.854 is unacceptable because it exceeds 0.7. Therefore, a new iteration is attempted with the line capacity increased to 4800 bps.

$$\rho = \left(\frac{1320}{118 \times 8} \right) \left[\frac{(118 + 34) \times 8}{4800} + \frac{5 \times 1977 \times 0.001}{100} + 0.006 \right]$$

$$= (1.398)(0.2533 + 0.1048)$$

$$\rho = 0.5006 < 0.7$$

The resulting value of ρ equal to 0.5006 is acceptable. Therefore, for the indicated traffic level of 1.320 kbps between Phoenix and Washington, D. C., a line capacity of 4800 bps is assigned.

As line capacity requirements increase, the following line combinations are assigned:

Voice grade equivalents	Line capacities, bps
1	2400
2	4800
3	7200
4	9600
5	9600, 2400
6	9600, 4800
7	9600, 7200
8	9600, 9600
9	9600, 9600, 2400
10	9600, 9600, 4800
etc.	

When multiple line assignments are required, the equation for ρ is evaluated with C equal to 9600 bps and the traffic term T modified to reflect the percentage of total line equivalents handled by a single 9600-bps line. For example, if six voice grade equivalents were required, i. e., one 9600- and 4800-bps line each, then a C = 9600 would be used and the traffic would be multiplied by a factor of four-sixths (or $9600/9600 + 4800$), which is equal to two-thirds. The assumption in this example is that if the requirement for ρ is satisfied with the 9600-bps line carrying two-thirds of the traffic, then it will be satisfied by the 9600- and 4800-bps lines together carrying the full traffic load.

VI. MULTIPLEXING

A. Criteria for Use

Time-division multiplexing is used in options 1, 2, and 3 in which usage has a significant effect on total network costs. Frequency-division multiplexing is useful only with low-speed lines (75 to 150 baud) that were not used in the networks; therefore, usage was not considered.

Multiplexing is most effective in cases where a closely spaced group of system terminations a long distance (greater than 1000 mi) from the switcher can be served by one multiplexed data stream. This criterion is met primarily in the one region (options 1, 2, and 3) where multiplexers were used. Some savings could have been provided by multiplexing in options 4 and 7, but the impact on total costs would be insignificant.

When multiplexing is used, dial-up backup capability is provided to prevent significant reduction in network availability. The magnitude of backup is an estimate, as hard values on equipment reliability are not available. Wide-area telephone service (WATS) is used to provide the backup lines. All backup capability is at 2400 bps.

B. Multiplexer Configurations Used

Cost details are given for the multiplex cases used. Costs are divided into recurring hardware lease costs with and without multiplexers. A cost savings equation is derived first on a monthly basis, then on an annual basis. Installation cost differentials are assumed to be insignificant.

1. Four 2.4-kbps Lines Multiplexed on One 9.6-kbps Line

a. Description. Four users remote to the switcher (regional-switching center, RSC) operating at 2.4 kbps, are combined on one voice line at 9.6 kbps. The multiplexer (MUX) is located at one of the remote users with the other users interfaced through 2.4-kbps lines to the MUX location. The MUX is built into the Bell 209A modem. The multiplexing capability could be obtained from other manufacturers at similar cost.

b. Costs (see Table B-6).

Table B-6. Costs for four 2.4-kbps lines multiplexed on one 9.6-kbps line

Hardware costs per month, dollars With multiplexers		Hardware costs per month, dollars Without multiplexers	
D1 line conditioning at \$27 line	= 27	Eight Bell 201 2.4-kbps modems at \$55/mo	= 440
Two Bell 209A 9.6-kbps modems at \$230/mo	= 460	Eight service terminals at \$40/mo	= 320
Six Bell 201 2.4-kbps modems at \$55/mo	= 330		
Eight service terminals at \$40/mo	= 320		
Totals	1,137		760

$$\text{Savings/month} = 760 - 1137 + 0.54 (\text{distance saved}) = -377 + 0.54 (D_S)$$

where 0.54 = cost of voice line per mile/month

$$\text{Savings/year} = -4524 + 6.48 (D_S)$$

$$D_S = \Sigma (\text{distance from RSC to states other than MUX state})$$

$$- \Sigma (\text{distance from MUX state to other states served by MUX})$$

2. Two 2.4-kbps Users Multiplexed on One 4.8-kbps Line

a. Description. The multiplex capability is built into the 4.8-kbps modems.

b. Costs (see Table B-7).

Table B-7. Costs for two 2.4-kbps users multiplexed on one 4.8-kbps line

Hardware costs per month, dollars With multiplexers	Hardware costs per month, dollars Without multiplexers
Two 4.8-kbps modems at \$150 = 300	Four Bell 201's at \$55 = 220
Two Bell 201 modems at \$55 = 110	Four service terminals at \$40 = 160
Four service terminals at \$40 = 160	
Totals	380

$$\text{Savings/month} = -190 + 0.54 (D_S)$$

$$\text{Savings/year} = -2280 + 6.48 (D_S)$$

where D_S is as given in Table B-6

3. WATS Dial Backup Costs. The following costs and criteria for use are the basis for dial backup using WATS lines.

a. Costs.

One WATS line (10 hr/mo) = 290/mo x 12 = 3480 yr

Additional use of WATS line = \$21.75/hr

One phone service = 29.50/mo x 12 = 354/yr

One Bell 201 modem = 55/mo x 12 = 660/yr

b. Criteria for dial backup hardware.

Up to six MUX locations

Eight WATS lines (10 hr/mo)

+ eight phones at RSC

+ two phones at each state on MUX

+ one Bell 201 at each MUX location

+ four Bell 201's at RSC

Seven to nine MUX locations

Eight WATS lines (20 hr/mo)

+ eight phones at RSC

+ two phones at each state multiplexed

+ one Bell 201 modem at each state multiplexed

+ four Bell 201 modems at RSC

More than nine MUX locations

Sixteen WATS line (10 hr/mo)

+ sixteen phones at RSC

+ two phones at each state multiplexed

+ one Bell 201 modem at each state multiplexed

+ eight Bell 201 modems at RSC

C. Cost Details for NALECOM Options.

Tables B-8 through B-14 give details of the MUX configurations for options 1, 2, and 3. In these tables the system terminations are generally designated by a number. The relation of the numbers to states is shown in Table B-15.

Note that for cases where Alaska and Hawaii are multiplexed, distance calculations are made to the international port of entry, which is Sacramento for links to Hawaii and Seattle for links to Alaska.

Table B-8. MUX configuration

OPTION 1

USAGE S - S 1977 - 1983

RSC AT 3 (PHOENIX)

MUX LOCATION	MUX CONFIG.	CONNECTED STATES	DIST. RSC-ST.	DIST. MUX-ST.	ANNUAL SAVINGS
OREGON (37)	4 @ 2.4 K	12, 47, 2	2923	639	10276
NEW HAMP. (29)	4 @ 2.4 K	19, 21, 45	6876	268	38295
NEW YORK (32)	4.8, 2.4, 2.4	7, 39	4480	222	24747
PENN. (38)	4.8, 2.4, 2.4	8, 30	4155	221	22648
WASH. D.C. (52)	4 @ 2.4	20, 46, 51	5935	122	33144
KENTUCKY (17)	4 @ 2.4	35, 42, 48	4821	508	23424
GEORGIA (10)	4 @ 2.4	9, 33, 40	5307	777	24830
MISS. (24)	4 @ 2.4	1, 4, 18	3861	568	16814
ILLINOIS (13)	4 @ 2.4	14, 22, 49	4448	662	20009
WYOMING (50)	4 @ 2.4	6, 34, 41	2653	858	7107
NEBRASKA (27)	4 @ 2.4	15, 16, 23	3429	643	13529

TOTAL \$234,823

DIALUP BACKUP COSTS

16 WATS LINES @ 3480/yr	=	55680
19 2.4 K MODEMS @ 660/yr	=	12540
100 phones @ 354/yr	=	35400

TOTAL 103620

TOTAL SAVINGS = 234823 - 103620
= 131203/Year

Table B-9. MUX configuration

OPTION 1

USAGE STATE TO NATIONAL 1977 thru 1979

RSC AT 52 (WASHINGTON, D.C.)

MUX LOCATION	MUX CONFIG.	CONNECTED STATES	DIST. RSC-ST.	DIST. MUX-ST.	ANNUAL SAVINGS
Idaho (12)	4 @ 2.4 K	37, 47, 2	7072	1151	33844
Utah (44)	4 @ 2.4	3, 11, 28	6625	1463	28925
So. Dakota (41)	4 @ 2.4	26, 34, 50	4628	1076	18492
Kansas (16)	4 @ 2.4	6, 31, 36	4244	1376	14060
Iowa (15)	4 @ 2.4	23, 27, 49	2685	644	8701
Miss (24)	4 @ 2.4	1, 4, 18	2573	568	8464

TOTAL 112486

DIALUP BACKUP COSTS

8 WATS Lines @ 3480/yr	=	27840
10 2.4 K Modems @ 660/yr	=	6600
56 Phones @ 354/yr	=	19824

TOTAL 54264

Total Savings = 112486 - 54264 = 58222/yr.

Table B-10. MUX configuration

OPTION 1

USAGE STATE TO NATIONAL 1980 - 1983

RSC AT 52 (Washington D.C.)

MUX LOCATION	MUX CONFIG.	CONNECTED STATES	DIST. RSC-ST.	DIST. MUX-ST.	ANNUAL SAVINGS
28	2 @ 2.4	11	2374	103	12443
12	4 @ 2.4	26, 37, 47(2)	6558	1039	31239
23	4 @ 2.4	34, 41, 49	3281	973	10431
27	4 @ 2.4	15, 16, 50	3369	729	12576
36	4 @ 2.4	6, 31, 43	4409	1332	15414

TOTAL 82103

DIALUP BACKUP COSTS

8 WATS Lines @ 3480/yr.	=	27840
9 201C Modems @ 660/yr.	=	5940
44 Phones @ 354/yr.	=	15576

TOTAL 49356

ANNUAL SAVINGS = 82103 - 49356 = 32567

Table B-11. MUX configuration

OPTION 2

USAGE 1977 - 1979

RSC AT 3 (Phoenix)

MUX LOCATION	MUX CONFIG.	CONNECTED STATES	DIST. RSC-ST.	DIST. MUX-ST.	ANNUAL SAVINGS
12	4 @ 2.4	37, 47, 2	3171	1151	8565
50	4 @ 2.4	6, 34, 41	2653	858	7107
15	4 @ 2.4	14, 23, 49	4172	475	19432
36	4 @ 2.4	4, 16, 27	3103	943	9472
24	4 @ 2.4	1, 40, 42	4705	1095	18868
48	4 @ 2.4	17, 46, 51	5481	667	26670
8	4 @ 2.4	7, 20, 30	6310	372	33954
29	4 @ 2.4	19, 39, 45	6858	298	37984

TOTAL 162052

DIALUP BACKUP COSTS

8 WATS LINES @ 6090/yr.	=	48720
12 201C Modems @ 660/yr.	=	7920
72 Phones @ 354/yr.	=	25488

TOTAL 82128

ANNUAL SAVINGS = 162052 - 82128 = 77924

Table B-12. MUX configuration

OPTION 2

USAGE 1980 - 1983

RSC AT 3 (Phoenix)

MUX LOCATION	MUX CONFIG.	CONNECTED STATES	DIST. RSC-ST.	DIST. MUX-ST.	ANNUAL SAVINGS
29	4 @ 2.4	19, 39, 45	6858	298	37984
51	4 @ 2.4	7, 8, 48	5987	636	30150
27	4 @ 2.4	15, 16, 23	3429	643	13529
4	4 @ 2.4	24, 36, 40	3882	1152	13166
50	4 @ 2.4	26, 34, 41	2975	1281	6453

TOTAL 101282

DIALUP BACKUP COSTS

8 WATS Lines @ 3480/yr.	=	27840
9 201C Modems @ 660/yr.	=	5940
48 Phones @ 354/yr.	=	16992

TOTAL

Annual Savings = 101282 - 50772 = 50510

Table B-13. MUX configuration

OPTION 3

USAGE 1977 THRU 1979

RSC AT 52 (Washington D.C.)

MUX LOCATION	MUX CONFIG.	CONNECTED STATES	DIST. RSC-ST.	DIST. MUX-ST.	ANNUAL SAVINGS
12	4 @ 2.4	37, 47, 2	7072	1151	33844
44	4 @ 2.4	5, 11, 28	7024	1494	31310
41	4 @ 2.4	26, 34, 50	4628	1076	18492
15	4 @ 2.4	16, 23, 27	2981	614	10814
36	4 @ 2.4	3, 6, 31	5068	1811	16581

TOTAL 111041

DIALUP BACKUP COSTS

8 WATS Lines @ 3480/yr.	=	27840
9 201C Modems @ 660/yr.	=	5940
48 Phones @ 354/yr.	=	16992

TOTAL 50772

Annual Savings = 111041 - 50772 = 60269

Table B-14. MUX configuration

OPTION 3

USAGE 1980 THRU 1983

RSC AT 52 (Washington D.C.)

MUX LOCATION	MUX CONFIG.	CONNECTED STATES	DIST. RSC-ST.	DIST. MUX-ST.	ANNUAL SAVINGS
28	2 @ 2.4	5 (11)	2375	103	12443
12	4 @ 2.4	26, 44, 47(2)	6033	986	28180
15	4 @ 2.4	34, 41, 50	4049	1485	12091
16	4 @ 2.4	27, 31, 36	3803	1017	14864
			TOTAL		67578

DIALUP BACKUP COSTS

8 WATS Lines @ 3480/yr.	=	27840
5 201C Modems @ 660/yr.	=	3300
34 Phones @ 354/yr.	=	12036

TOTAL 43176

Annual Savings = 67578 - 43176 = 24402

Table B-15. Numerical designations used for system terminations

State	Capital	State	Capital
1. Alabama	Montgomery	27. Nebraska	Lincoln
2. Alaska	Juneau	28. Nevada	Carson City
3. Arizona	Phoenix	29. New Hampshire	Concord
4. Arkansas	Little Rock	30. New Jersey	Trenton
5. California	Sacramento	31. New Mexico	Santa Fe
6. Colorado	Denver	32. New York	Albany
7. Connecticut	Hartford	33. North Carolina	Raleigh
8. Delaware	Dover	34. North Dakota	Bismark
9. Florida	Tallahassee	35. Ohio	Columbus
10. Georgia	Atlanta	36. Oklahoma	Oklahoma City
11. Hawaii	Honolulu	37. Oregon	Salem
12. Idaho	Boise	38. Pennsylvania	Harrisburg
13. Illinois	Springfield	39. Rhode Island	Providence
14. Indiana	Indianapolis	40. South Carolina	Columbia
15. Iowa	Des Moines	41. South Dakota	Pierre
16. Kansas	Topeka	42. Tennessee	Nashville
17. Kentucky	Frankfort	43. Texas	Austin
18. Louisiana	Baton Rouge	44. Utah	Salt Lake City
19. Maine	Augusta	45. Vermont	Montpelier
20. Maryland	Annapolis	46. Virginia	Richmond
21. Massachusetts	Boston	47. Washington	Olympia
22. Michigan	Lansing	48. West Virginia	Charleston
23. Minnesota	St. Paul	49. Wisconsin	Madison
24. Mississippi	Jackson	50. Wyoming	Cheyenne
25. Missouri	Jefferson City	51. Washington, D. C.	City
26. Montana	Helena	52. Washington, D. C.	NCIC

APPENDIX C

SWITCHER CONFIGURATIONS AND COST BASES

I. INTRODUCTION

This Appendix presents the design philosophy and functional flow of the message switcher. Specific hardware configurations are given which have been developed for discrete throughput levels that cover the range of possible switched traffic for the various network options. These configurations have been developed for the purpose of cost modeling. Costs are given for each hardware configuration and for the various NLETS upgrades.

II. DESIGN PHILOSOPHY

Three factors dominated the functional and system design of the message switcher: (1) to minimize the response time in the interest of officer safety, (2) to maximize its throughput, and (3) to ensure reliability.

It was felt that the major user's requirement was to have a fast, responsive system. To ensure a fast response, several design requirements have been imposed. All messages will reside only in core memory queues. All messages are prioritized, with the officer-safety type messages given first priority. Full-duplex protocols will be used for all data transmission between the regional message switchers and, where possible, between the regional message switchers and the system terminations (state computers). Where necessary, multiple lines will be used to decrease response time and to increase throughput.

Reliability of the message switchers has been emphasized. Each message switching center will have redundant systems with automatic switchover. All messages, regardless of priority, will be stored in core. Rotational memory will not be used. Additionally, the message switching logic will be designed to prevent congestion caused by abnormally high message-arrival rates. Input of messages will be inhibited when queue space is full. In the same priority level, output of messages will have priority over input, and the capability to defer low-priority messages will be provided.

III. MESSAGE SWITCHER FUNCTIONAL FLOW

Figure C-1 is a functional flow diagram. The block labels do not imply a physical realization of the message switcher.

The input COMMUNICATION LINE INTERFACES block furnishes the electrical interface for the modem and the logic that is required for its conditioning. Through use of the receiver clock furnished by the modem, it also converts the non-return-to-zero (NRZ) bit stream into assembled 8-bit characters (including parity).

The MESSAGE ASSEMBLY block assembles messages by deblocking the character stream.

The ERROR CONTROL block provides an error detection capability and initiates error recovery procedures. Although shown as a distinct logical function, this capability is highly dispersed. The character parity is most efficiently checked during the assembly of characters in the interface. It is necessary for a logical block to be formed before block or frame parity can be checked. Additionally, all internal data transfers require a parity check.

The MESSAGE CONTROL AND ROUTING block is primarily logic which examines the assembled message, determines its priority, forms the appropriate pointers, and places them in the proper queue. (The pointers are queued, not the messages.) For routing purposes, it is also necessary for this functional block to maintain the status of the network.

The BUFFER AND QUEUE block furnishes storage which is used to assemble messages on input and to buffer them for output and to form space to queue the message pointers. Efficient use of storage is achieved through use of a dynamic allocator and common use of a buffer space by both input and output. This functional block provides the message switcher its inherent capability to smooth traffic.

The MESSAGE DISASSEMBLY block segregates the message into logical blocks for output. It also disassembles the blocks into a character stream for presentation to the communication line interface.

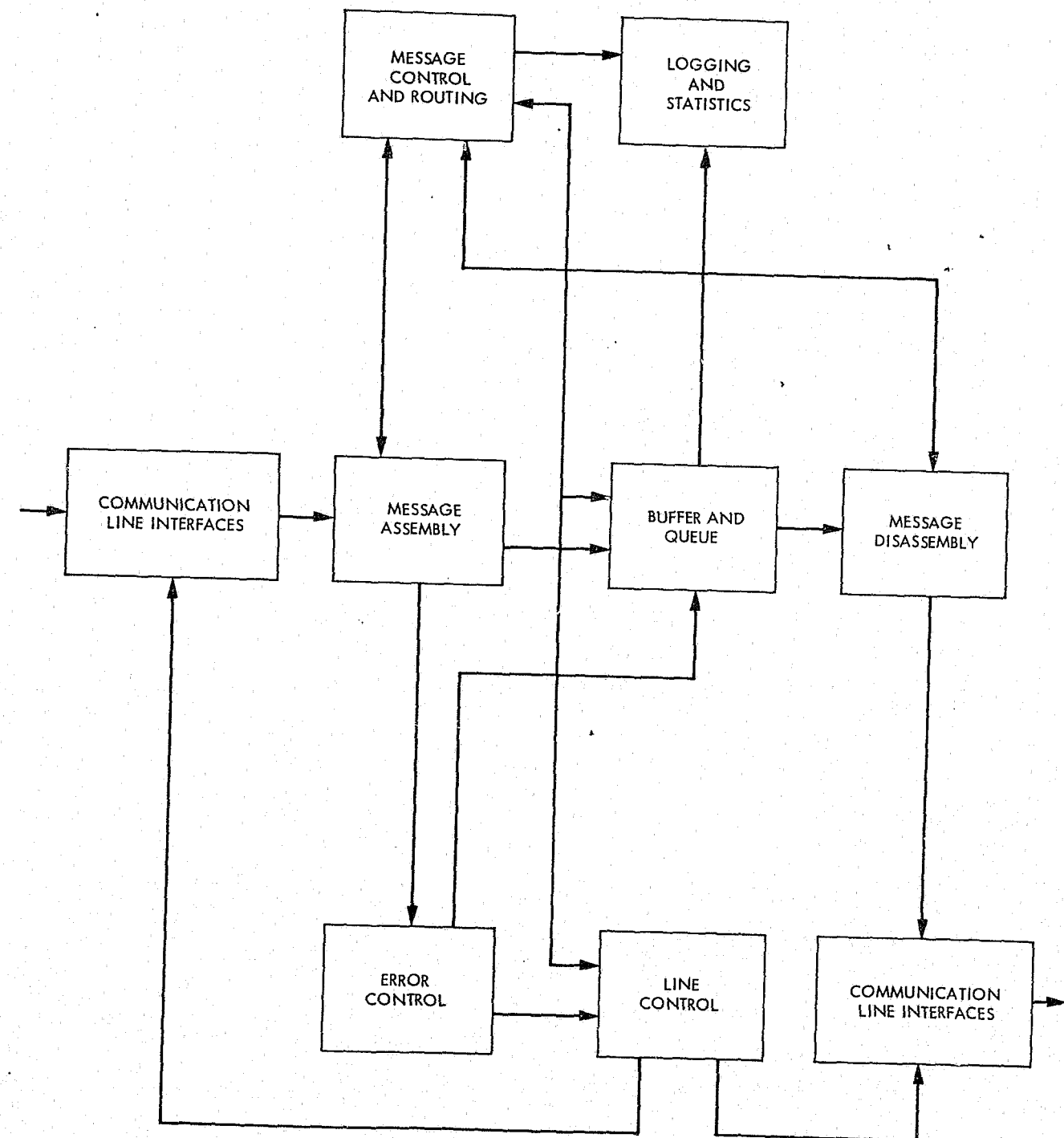

Fig. C-1. Regional message switcher functional block diagram

The LINE CONTROL block provides the capability of controlling and ordering the flow of data between the various message switchers. It also determines which line discipline is to be used. Full-duplex, half-duplex, polled, or contention line discipline capabilities will be furnished.

The output COMMUNICATION LINE INTERFACE converts the character stream to a NRZ bit stream. It furnishes the logic necessary to condition the modem for transmission and also furnishes the necessary electrical interface.

The LOGGING AND STATISTICS block provides the capability of collecting and forming statistics that will be useful in tuning the network. It will also provide an audit trail to the extent that it is required.

Although not shown in Fig. C-1, at least one switcher in the network will be capable of outputting and inputting high-speed data to and from magnetic tape and a line printer. This capability is furnished for the purpose of program development and maintenance. It also provides the capability of outputting statistics.

IV. HARDWARE CONFIGURATIONS

Three specific message switcher hardware configurations have been developed for the purpose of cost modeling. The use of specific hardware (i.e., PDP-11's) does not imply a design requirement. The specific equipment was chosen for the purpose of cost modeling as being typical. The three configurations cover the message throughput requirements for the estimated range of network traffic that each switcher must handle in the various network options.

Figure C-2 gives the message switcher architecture that has been used. The use of this architecture does not imply a system design requirement, but rather was developed for the purpose of cost modeling as being typical. This architecture was used for all configurations. Complete redundancy has been used because of the reliability requirements. Redundancy requires the use of the bus switches. The line printer and magnetic tapes are non-redundant peripherals for use in the network operation center only.

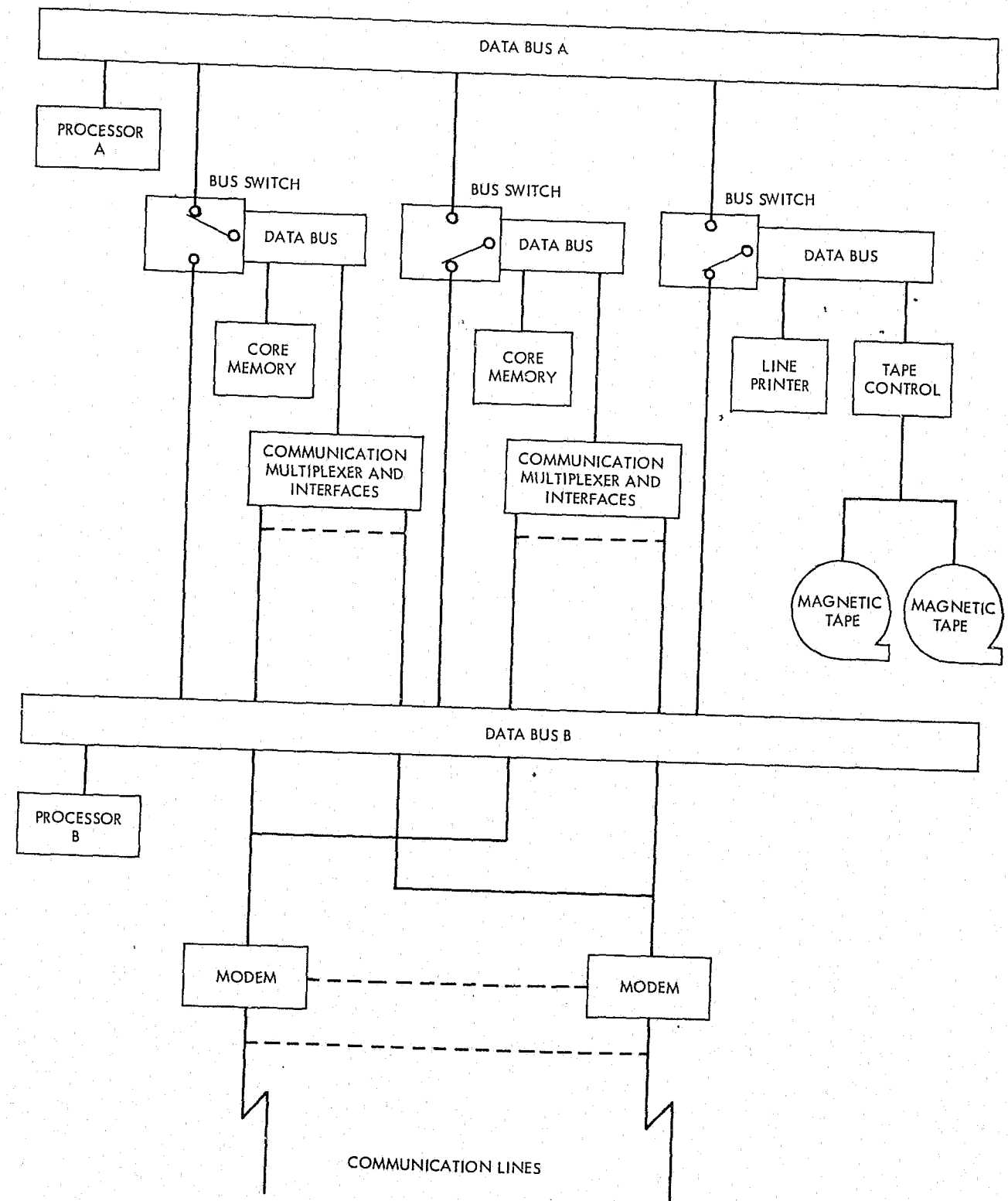

Fig. C-2. Message switcher functional block diagram

The matrix given is to be used for determining which of the message switcher configurations (A, B, or C) is to be used for the different network options.

Throughput, kbps	Number of lines		
	1-20	21-40	41-60
80	A	B	B
160	B	B	C
240	C	C	C

The cost for message switchers A, B, and C include complete hardware redundancy. Costs for non-redundant configurations can be obtained by dividing the number of units in each line item by two, then recalculating costs. There is no requirement for bus switchers in non-redundant configurations. Since in any option at least one switcher is redundant, software costs do not change.

A. Software Costs

All of the processors chosen in configurations A, B, and C have the capability of expanding their core to 128,000 words (16-bit). This capability was necessitated by the amount of software required; the lack of rotational mass memory dictated by reliability and response time, and the network philosophy of loading the communication lines to 0.7. All of the processors are relatively fast and well suited for communications handling tasks.

The costs of configurations A, B, and C do not include the cost of the communication line interfaces or the core required for buffering and queuing. These costs are identified in Section E of this Appendix. Costs for equipment pertaining to the operations center for all configurations is given in Table C-1.

Software costs for the various network options (not including the upgrading of NLETS) are given in Table C-2. Two sets of software will be used: one set basic to all options, and the other added when the number of regions is ten or more.

Table C-1. Operations center equipment

Equipment	Number of units	Cost, dollars			
		Unit cost	Three-shift maintenance (per month)	Hardware total	Maintenance total (7 yr)
LP11-KA 300 character/min printer, 132-column 96-character, including control	One	19,000	160	19,000	13,400
TM11-EA Tape controller and tape transport, nine-track, 800 bpi, 45 ips	One	10,700	190	10,700	16,000
TU10-EE Nine-channel industry-compatible tape transport, 800 bpi, 45 ips	One	7,500	140	7,500	11,800
Total				37,200	41,200
G&A (10%)				3,700	
Subtotal				40,900	
Profit (9%)				3,700	
Total				44,600	41,200
Total, hardware and maintenance					85,800

Table C-2. Software costs

Equipment	Man-years	Cost, dollars
Basic set		
Dedicated supervisor: streamlined	1.0	
Buffer management and queue control	1.0	
Protocol and data link control: BSC and SDLC	0.5	
Message switching	1.0	
Message header analysis	0.5	
System recovery: switchover routine	1.0	
On-line diagnostics	1.0	
Logging and statistics	<u>0.5</u>	
Total (dollars/man year)	6.5	234,000
Computer time		<u>60,000</u>
Total		294,000
Extended set		
Routing and traffic management	0.5	
Inter-computer communications	0.5	
Total	<u>1.0</u>	36,000
Computer time		<u>10,000</u>
Total		46,000

B. Configuration A

Specific hardware and detailed costs for configuration A are presented in Table C-3.

Table C-3. Configuration A

Equipment	Number of units	Cost, dollars			
		Unit cost	Three-shift maintenance (per month)	Hardware total	Maintenance total (7 yr)
PDP-11/40-BK/BL KD11-A CPU MF11-UP (16,000 words, byte parity, 980 nsec) Serial LA30 DEC writer Cabinet	Two	17,700	224	35,400	37,600
KT11-D Memory management	Two	2,500	40	5,000	6,800
KG11-A Communications arithmetic element (provides CRC and LRC)	Two	800	12	1,600	2,000
MM11-UP (16,000 words, byte parity, 980-nsec expander core memory)	Two	5,600	50	11,200	8,400
MF-UP (16,000 words, byte parity, 980-nsec core memory and control)	Two	6,300	50	12,600	8,400
KW11-P Programmable real-time clock	Two	700	6	1,400	1,000
PR11 300-character/s paper tape recorder, including control	Two	2,400	30	4,800	4,800
H960-DA Cabinet	Two	2,400	0	4,800	0
Total		38,400	412	76,800	69,000
G&A (10%)		3,800		7,700	
Subtotal		42,200		84,500	
Profit (9%)		3,800		7,600	
Total		46,000		92,100	69,000
Total, hardware and maintenance					161,100

C. Configuration B

Specific hardware and detailed costs for configuration B are presented in Table C-4. Configuration B differs from A in that a more powerful processor and 32,000 words of fast semiconductor memory (490 ns) are provided. This processor's instruction set, when compared with that of A, has more sophisticated instructions, more general registers, and a more powerful interrupt facility.

Table C-4. Configuration B

Equipment	Number of units	Cost, dollars			
		Unit cost	Three-shift maintenance (per month)	Hardware total	Maintenance total (7 yr)
PDP11/45 - CU					
KB11-A CPU MF11-UP (16,000 words, byte parity, 980 nsec) Serial LA30 DEC writer Cabinet	Two	27,800	366	55,600	61,500
KT11-D Memory management	Two	2,500	40	5,000	6,800
KG11-A Communications arithmetic element	Two	800	12	1,600	2,000
MS11-BC First MOS memory control	Two	2,000	24	4,000	4,000
MS11-BD Second MOS memory control	Two	1,500	24	3,000	4,000
MS11-BT 4,000 MOS memory with byte parity, 490 nsec	Sixteen	3,400	40	54,400	53,800
KW11-P Programmable real-time clock	Two	700	6	1,400	1,000
PR11 300-character/s paper tape reader, including control	Two	2,400	30	4,800	4,800
H960-DA Cabinet	Two	2,400	0	4,800	0
Total				134,600	137,900
G&A (10%)				13,500	
Subtotal				148,100	
Profit (9%)				13,300	
Total				161,400	137,900
Total hardware and maintenance					299,300

D. Configuration C

Specific hardware and detailed costs for configuration C are presented in Table C-5. This configuration differs from B in that a dual processor architecture is used.

Table C-5. Configuration C

Equipment	Number of units	Cost, dollars			
		Unit cost	Three-shift maintenance (per month)	Hardware total	Maintenance total (7 yr)
PDP11/50-CW					
KB11-A CPU MF11-UP (16,000 words, byte parity, 980 nsec) KT11-D Memory management Serial LA30 DEC writer MS11-BC First MOS memory control MS11-BT (16,000 words, byte parity, 490 nsec, MOS memory)	Two	46,300	770	92,600	129,400
PDP11/45-CU					
KB11-A CPU MF11-UP (16,000 words, byte parity, 980 nsec) Serial LA30 DEC writer Cabinet	Two	27,800	366	55,600	61,500
KG11-A Communications arithmetic element	Four	800	12	3,200	4,000
KT11-D Memory management	Two	2,500	40	5,000	6,800
KW11-P Programmable real-time clock	Four	700	6	2,800	2,000
PR11 300-character/s paper tape reader including control	Two	2,400	30	4,800	4,800
H960-DA Cabinet	Four	2,400	0	9,600	0
DA11-F UNIBUS window	Two	6,000	80	12,000	13,400
DT03-FP Programmable UNIBUS switch	One	8,400	150	8,400	12,600
Total				194,000	234,500
G&A (10%)				19,400	
Subtotal				213,400	
Profit (9%)				19,200	
Total				232,600	234,500
Total, hardware and maintenance					467,100

E. Line Interface Costs

Line interface costs were developed separately to facilitate the development of the costs of the various network options. The organizational philosophy used was that each port would have a full-duplex capability, that the assembly buffers would be fixed length, and that the output buffers (queues) would be of variable length. The output buffers would be managed by a dynamic memory allocator. The queue space to be provided would be such that the probability of overflow, with an average facility utilization of 0.7, would be 0.01. The cost model is as follows:

$$\text{Line Interface Costs (K\$)} = n_1(14.3) + n_2(18.0) + \left\lceil \frac{(n_1 + n_2)(BL + 10ML)}{32000} \right\rceil (22.8)$$

where

n_1 = number of communication lines \leq 9600 bps

n_2 = number of 50-kbps communication lines

BL = blocking factor

ML = average message length

The expression $\lceil a/b \rceil$ means to perform the indicated operation a/b and round off to the nearest integer.

Line interface costs for non-redundant switchers are:

$$\text{Line Interface Costs (K\$)} = n_1(7.2) + n_2(9.0) + \left\lceil \frac{(n_1 + n_2)(BL + 10ML)}{32000} \right\rceil (11.4)$$

F. Full-Duplex Converters

Some of the network options consider the use of full-duplex circuits and protocols. Because of hardware and software deficiencies, many states and the NCIC presently lack this capability. To overcome this difficulty, the use of half-duplex to and from full-duplex converters has been planned for application where necessary. A small minicomputer with the appropriate amount of core for buffering has been estimated for this use. Estimated costs are:

Computer hardware:	\$44,000
Software:	<u>\$40,000</u>
Total:	\$84,000

G. NLETS Upgrade Costs

Options 1, 2, 4, and 7 consider the use of the existing NLETS message switcher to take advantage of the sunk costs. For this reason several analyses have been performed to determine the NLETS throughput capability and its ability to be upgraded to handle the traffic necessary for its inclusion in the various networks.

1. Option 1. Option 1 assigns all of the state-state traffic to the NLETS switcher. Initially, an analysis was performed to determine the throughput capability of the existing switcher. This analysis showed the switcher to be capable of handling all of the state-state traffic until the spring of 1979, at which time it must be upgraded to handle the traffic through 1983.

A second analysis was performed to determine the throughput improvement realized by two different upgrades. The analysis showed both upgrades capable of handling the projected 1983 state-state traffic. The costs given here are for the most efficacious upgrade. This upgrade entails customizing the existing code to make it more efficient (execute faster) and adding bulk core memory for the purpose of forming fast access queues for the inquiry/response type messages. Estimated costs are:

Customize existing NLETS code:	\$ 30,000
Bulk core, with controller:	<u>\$ 90,000</u>
Total:	\$120,000

2. Option 2. Option 2 is a one-region network with the switcher located at Phoenix. Because of the high-throughput and low-delay requirements, the present switcher and its software cannot be used. Only the sunk costs of some of the line interface units can be recovered by using them where transmission rates less than 3600 bps are required. To recover these costs entails specifying the same systems manufacturer as made the existing equipment. These costs are given in Table C-6 and include redundancy as required.

3. Options 4 and 7. Options 4 and 7 are both two-region networks with Phoenix (NLETS) as the western switcher, with the network operations center located at the eastern switcher. Again, as in option 2, these options will require new hardware and software for NLETS, with some of the sunk costs being recovered from use of some of the line interface units. The costs of options 4 and 7 are the same. They are given in Table C-7 and include redundancy. The software costs are bundled. Maintenance costs given in Table C-7 do not include that for the existing line interface units.

Table C-6. Costs for option 2

Equipment	Cost, dollars	Annual maintenance cost, dollars
Basic computer hardware, except line interface units	520,000	46,800
Operations center equipment (one line printer and two magnetic tape units)	19,000	1,900
Line interface units	541,000	48,700

Table C-7. Costs for options 4 and 7

Equipment	Cost, dollars	Annual maintenance cost, dollars
Basic computer hardware, except line interface units	360,000	32,400
Line interface units	153,000	13,700

APPENDIX D MICROWAVE COSTS

I. INTRODUCTION

Microwave links are required for option 7 to provide communications from the satellite ground station to the system termination served by the station. This Appendix describes hardware required and subsequent costs, and compares common carrier costs to microwave costs. Problems such as vulnerability to destruction and difficulty in obtaining frequency, site, and path approval are not considered. Neither are economic factors such as the effects of inflation or the cost of money.

Many assumptions were made for estimating purposes. These assumptions are:

Link length:	30 mi average
Repeaters/link:	one
Frequency:	two or six GHz bands
Antenna height:	100 ft
Antenna size:	8 ft
Commercial power:	not available at repeaters
Buildings:	space available at Metropolitan terminal
System life:	7 yr
Capacity:	half-duplex video link (black and white) and one full-duplex 50-kbps data channel

Costs are separated for terminals and repeaters in both non-redundant and redundant configurations, although redundant costs were used in option 7. Also separated are the common costs not directly associated with equipment or operation. Operation and maintenance are recurring costs which are separately shown.

II. SITE COSTS

A. Terminal-Satellite Location (see Table D-1)

Table D-1. Costs for terminal-satellite location

Equipment	Cost, dollars	
	Redundant	Non-redundant
1) Electronics		
a) Radio, video, data MUX	46,000	28,000
b) Tower	13,000	13,000
c) Antennas, waterproof	7,000	3,500
d) Waveguide system	3,200	1,600
2) Support		
a) Battery/rectifier	3,000	2,000
b) Auxiliary generator	2,500	2,500
c) Emergency	700	700
Subtotal	75,400	51,300
3) Site requirements		
a) Building (250 square feet)	5,000	5,000
b) Commercial power hookup	800	800
c) Outside lighting	1,000	1,000
d) Fencing	2,400	2,400
e) Access road	0	0
f) Site preparation	1,000	1,000
4) Other items		
a) Real estate	0	0
b) Initial installation and checkout	4,000	5,500
c) Miscellaneous hardware	2,000	2,000
Satellite terminal total	91,600	67,500

B. Terminal-Metropolitan Location (see Table D-2)

Table D-2. Costs for terminal-metropolitan location

Equipment	Cost, dollars	
	Redundant	Non-redundant
1) Electronics		
a) Radio, video, data MUX	46,000	28,000
b) Tower	13,000	13,000
c) Antennas	7,000	3,500
d) Waveguide	3,200	1,600
2) Support		
a) Battery/rectifier	3,000	2,000
b) Auxiliary generator	5,000	5,000
c) Emergency	700	700
Subtotal	77,900	53,800
3) Building facilities (10-yr use)	12,000	12,000
4) Facility preparation, equipment, installation, etc.	4,000	4,000
5) Miscellaneous hardware	1,000	1,000
Total	91,900	67,800

C. Repeater Costs (see Table D-3)

Table D-3. Repeater costs

Equipment	Cost, dollars	
	Redundant	Non-redundant
1) Electronics		
a) Radios	40,000	20,000
b) Towers	13,000	13,000
c) Antennas (four)	14,000	7,000
d) Waveguide system	6,400	3,200
2) Support equipment		
a) Backup power	5,000	4,000
b) Auxiliary generator	5,000	5,000
c) Emergency	700	700
Subtotal	<u>84,100</u>	<u>52,900</u>
3) Site requirements		
a) Building	10,000	10,000
b) Commercial power	10,000	10,000
c) Fencing	2,400	2,400
d) Lights	1,000	1,000
e) Road access	2,500	2,500
f) Site preparation	2,000	2,000
4) Real estate	5,000	5,000
5) Equipment installation and checkout	3,000	3,000
6) Miscellaneous hardware	<u>2,000</u>	<u>2,000</u>
Total	123,000	91,800

D. Equipment Cost Summary (see Table D-4)

Table D-4. Equipment cost summary

Equipment	Cost, dollars	
	Redundant	Non-redundant
1) Terminal-satellite location	75,400	51,300
2) Terminal-metropolitan location	77,900	53,800
3) Repeater	<u>84,100</u>	<u>52,900</u>
Total	237,400	158,000

III. COMMON COSTS: MICROWAVE LINK

	Cost, dollars	
	Redundant	Non-redundant
Frequency planning, path		
Engineering and survey	5,000	5,000
Test equipment: 3% of equipment costs		
Spare parts: 5% of equipment costs		
Documentation: 1% of equipment costs		
Engineering: 10% of equipment costs		
Transportation, etc.: 1% of equipment costs		
20% =	<u>47,500</u>	<u>31,600</u>
	52,500	36,600

IV. RECURRING OPERATION AND MAINTENANCE COSTS PER LINK (REDUNDANCY NOT SIGNIFICANT)

Maintenance contracts-electronics:	5,000/yr
Maintenance contracts-backup power system:	2,000/yr
Electrical power consumption:	1,000/yr
Insurance:	1,500/yr
Taxes:	1,500/yr
Miscellaneous support:	<u>1,000/yr</u>
Annual operation and maintenance cost	\$12,000

V. TOTAL COSTS: 30-mi MICROWAVE

A. Purchased Link

With the assumptions and component costs developed in Sections I through IV, the total cost for a redundant microwave link is:

Installation costs

One satellite station terminal: 91,600

One metropolitan terminal: 91,900

One repeater: 123,000

\$306,500

Common costs: 52,500

Base installation costs: \$359,000

Recurring costs: 12,000/yr

Annual costs (7-yr basis) = $359,000/7 + 12 = 63,000$

B. Common Carrier Leased Link Costs

Two (40-kbps) channels at \$6.50/mi/mo × 30 mi × 12 mo = 4,680

Four service terminals at \$425/mo × 12 mo = 20,400

One TV channel × \$0.75/mi/hr × 20 hr/mo × 12 × 30 mi = 5,400

Two video terminal connections 10 times/mo ×
12 mo/yr × \$80/connection = 19,200

Total annual lease \$49,680

VI. CONCLUSIONS

Costs for common carrier facilities (\$49,700/yr) vs purchased microwave (\$68,000/yr) indicates that common carrier usage is most effective. The assumption is made in costing option 7, however, that common carrier facilities from the ground stations to the city served are not available. Thus, for each satellite ground station using microwave connections to the city served, costs are \$395,000 for installation and \$12,000/yr for maintenance (recurring). It

is estimated in option 7 that two out of three ground stations will require microwave installations. It should be noted that the common carrier cost analysis is for 20 hr of TV transmission per month, while the microwave capability has no limitation and usage. If TV usage doubles, the microwave system is cost effective.

APPENDIX E

SATELLITE SYSTEM CONFIGURATION AND COST

I. INTRODUCTION

This Appendix describes the satellite capability provided in option 7. As noted in Section II-B of this publication, no hard requirements for video were identified. Option 7 provides strong satellite data and video transmission using leased space-link (satellite) capability with NALECOM-provided ground stations. Video and data hardware allow both inter-state usage in support of the NALECOM Network and intra-state usage if desired. However, space-link lease costs are provided only for NALECOM usage.

II. SATELLITE SYSTEM DESCRIPTION

A. Configuration

Fourteen ground stations are installed in option 7. The Washington, D. C. station is designated as the master with other stations as slaves. Digital data transmission is always between the master and one of the slave stations (see Fig. E-1). If two slave stations wish to communicate, they do so through the master; i. e., station 1 transmits through the satellite to the master station, at which the eastern regional switching computer is located. The computer examines the message for desired routing then routes the message through the satellite to station 2. This configuration provides the desired routing at minimum ground station cost.

Video transmit/receive capability is available at all ground stations. Any station can transmit video, and all other stations are able to receive the video transmissions if desired.

The basic configuration for the slave stations is shown in Fig. E-2. Note that three data channels are provided: one normally in use by NALECOM, the second available for state use, and the third as a spare. One of the up and down converters and one transmitter are used for data transmission. The second and third transmitters are used for video or backup to the data transmitter, in case of failure. Two video uplinks and downlinks could be provided

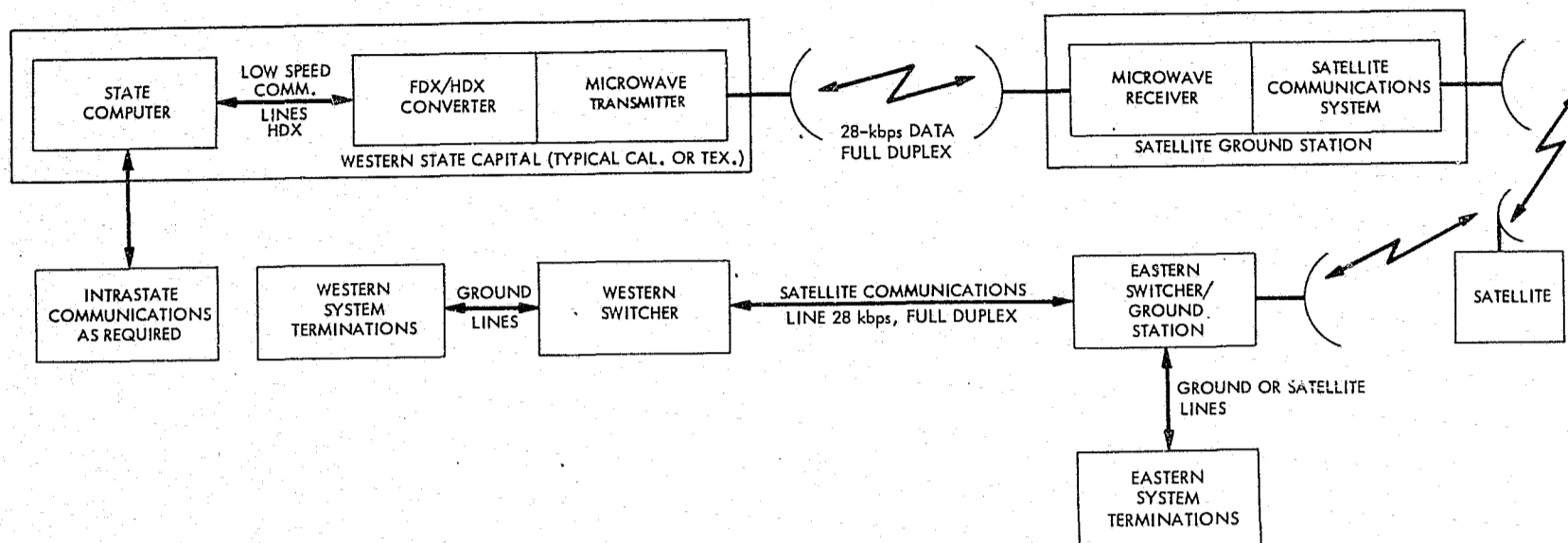

Fig. E-1. Typical data communications configuration for a western state with satellite capability

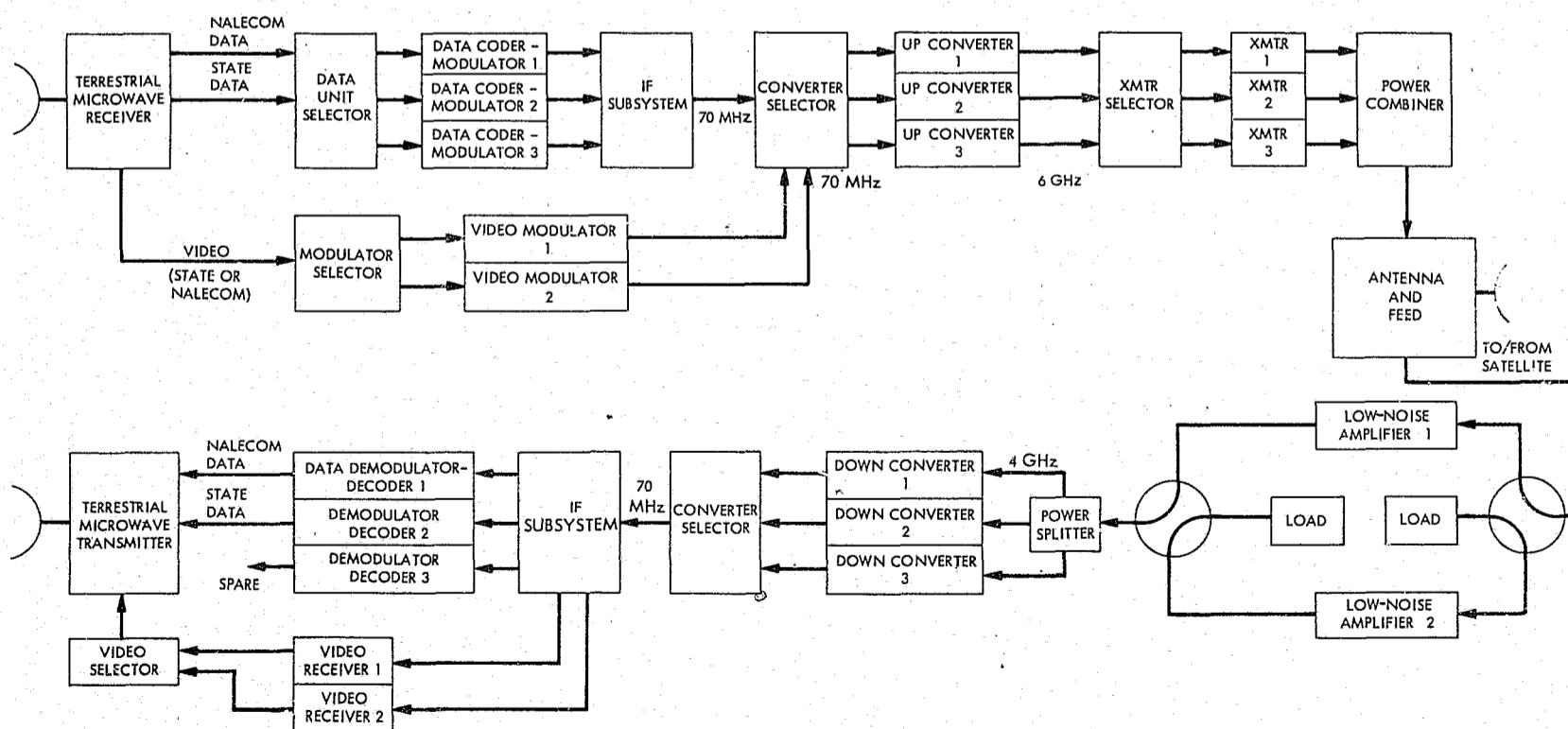

Fig. E-2. Typical ground station block diagram

if all hardware is operational. The microwave capability provides communications to the local city served by the satellite. This microwave provides two full-duplex data channels, but only one simplex video channel. Thus, only a simplex video capability is provided. However, addition of video generation and/or recording equipment at the ground station can give the capability of transmitting on two channels, and receiving on two channels.

B. Performance

Two satellite transmission capabilities are provided: digital data transmission and analog video. Digital data are transmitted at a data rate of 28 kbps, convolutionally coded, at rate 1/2. Bit error rate of less than or equal to 1×10^{-5} is provided.

The most critical link is the video link, where the performance goal is a peak-to-peak video to weighted RMS noise ratio of 54 dB. This goal is consistent with that desired for cable TV head-ends. This allows additional loss to users, attributable to terrestrial links, and video generation equipment such that a signal-to-noise ratio of 46 dB is available to users.

As the video link is the most critical, performance calculations are shown only for video in Tables E-1 and E-2, which give design and worst-case estimates of performance for a station located at the upper edge of the CONUS. Stations within the United States will perform up to 2 dB better than shown.

C. Cost Details

All hardware costs are shown unburdened. Cost data shown in option 7 tabulations include burden for hardware assuming that JPL or a similar agency would procure the hardware. Lease and maintenance costs in option 7 are unburdened, assuming the NALECOM Network management will arrange for these services. Cost estimates were obtained from discussions with suppliers and from manufacturers' price lists. Cost data were obtained during calendar year 1974. In general, hardware procurement and space link lease costs are decreasing.

Table E-1. Uplink design: video uplink from NALECOM ground station to WESTAR-type spacecraft

Item	Parameter	Unit	Design value	Worst case	Remarks
1	Transmitter power Power: 1.5 kW	dBW	31.3	30.8	
2	Feed losses	dB	-0.5	-1.0	
3	Transmitter antenna gain Antenna size: 32 ft	dBI	53.8	53.1	
4	Antenna pointing loss	dB	0	0	
5	Space loss Frequency: 6175 MHz Range: 39,540 km	dB	-200.2	-200.2	Range used to upper United States
6	Polarization loss	dB	0	0	
7	Atmospheric loss	dB	-0.1	-0.2	
8	Receiver antenna gain	dBI	26	25	
9	Antenna pointing loss	dBI	0	0	
10	Receiver circuit loss	dB			
11	Signal power to receiver (items 1-10)		-89.7	-92.5	
12	Receiver noise spectral density System temperature: 1738°K	dBW/Hz	-196.2	-196.2	Worst case G/T of -7.4 dB/°K
13	Receiver bandwidth Bandwidth: 30 MHz	dB-Hz	74.8	74.8	
14	Receiver noise power (items 12 and 13)	dBW	-121.4	-121.4	
15	Carrier-to-noise ratio (items 11-14)	dB	31.7	28.9	
16	Threshold carrier-to-noise ratio	dB	20	20	
17	Margin (items 15 and 16)		11.7	8.9	

Table E-2. Downlink design: video downlink from WESTAR-type spacecraft to NALECOM ground station

Item	Parameter	Units	Nominal value	Worst case	Remarks
1	Transmitter power Power, 5W	dBW	6.99	6.99	
2	Feed losses	dB	-0.99	-0.99	
3	Transmitter antenna gain	dBd	28	27	
4	Antenna pointing loss	dB	0	0	Included in item 3
5	Space loss Frequency: 3950 MHz Range: 39,540 km	dB	-196.3	-196.3	
6	Polarization loss	dB	0	0	
7	Atmospheric attenuation	dB	-0.1	-0.2	
8	Receiver antenna gain Antenna size: 32 ft	dBd	50.3	49.8	
9	Antenna pointing loss	dB	0	0	
10	Receiver circuit loss	dB	-0.5	-0.5	
11	Signal power to receiver (items 1-10)	dBW	-112.6	-114.2	
12	Receiver noise spectral density System temperature: 150°K	dBW/Hz	-206.8	-206.8	See Note 1
13	Receiver bandwidth Bandwidth: 30 MHz	dB-Hz	74.8	74.8	
14	Receiver noise power (items 12 and 13)	dBW	-132.0	-132.0	
15	Carrier-to-noise ratio (items 11-14)	dB	19.4	17.8	
16	Uplink carrier-to-noise ratio from Table E-1	dB	31.7	28.9	
17	Total carrier-to-noise ratio	dB	19.1	-17.5	See Note 2
18	Threshold carrier-to-noise ratio	dB	17.3	17.3	
19	Margin (items 17 and 18)	dB	1.8	0.2	
20	FM improvement If bandwidth = 4.2 MHz, modulation index = 2.5	dB	18.2	18.2	
21	Noise weighting	dB	10.2	10.2	
22	Pre-emphasis	dB	2.3	2.3	
23	Conversion of signal-to-noise ratio From $\frac{RMS}{RMS}$ to $\frac{Pk-Pk picture}{RMS noise}$	dB	6	6	
24	Signal-to-noise ratio = $\frac{Pk-Pk picture}{RMS noise}$ (items 17-23)	dB	55.8	54.2	
25	Required signal-to-noise ratio	dB	54	54	
26	Margin (items 24 and 25)	dB	1.8	0.2	

Notes:

- Noise spectral density = $-228.6 + 10 \log_{10} T_s$.
- $CNR_{total} = \frac{1}{\frac{1}{CNR_{uplink}} + \frac{1}{CNR_{downlink}}}$. Carrier-to-noise ratios are not in decibel form.
- FM improvement = $10 \log_{10} [3\beta^2 (\beta + 1)]$, where β is the modulation index.

1. Ground Station Hardware. Table E-3 provides the cost estimates for standard slave ground stations. The master ground station also uses this configuration when interfacing with only one other ground station.

For the next six additional slave ground stations (2 through 7) added, redundant data transmit/receive hardware is added to the master ground station at a cost of \$40,000 per slave.

For the next six slave stations added (8 through 13), non-redundant data transmit/receive hardware is added to the master station at a cost of \$20,000 per slave.

2. Ground Station Operations and Maintenance.

a. Personnel. All ground stations were assumed to be staffed. The staffing shown could be reduced by using more station automation, but total costs should be similar. Costs used were:

- First station with video: four persons required at \$20,000/yr/man = \$80,000/yr.
- Each additional station: two persons required at \$20,000/yr/man = \$40,000/yr.

3. Space Link Lease Costs.

a. Video. Video costs were obtained as a budgetary estimate from WESTAR representatives at \$1,400/h. Usage of 20 h of video transmission per month is assumed during phases 7b and 7c; 40 h/month is assumed during phase 7d.

b. Data channels. No hard figures were obtained for data channel lease. However, a cost of \$50,000 annually for lease of a single full-duplex channel was used in estimates and is felt to be reasonable.

Table E-3. Satellite ground station cost estimate:
standard ground station

Item	Description	Size, power, etc.	Number required	Cost, dollars	
				Each	Total
1	Antenna	28-ft Cass. fd., 15 kW	One	55,000	55,000
2	Transmitter	1.5 kW	Three	45,000	135,000
3	Up converter		Three	9,000	27,000
4	Coder/modulator	Rate 1/2	Three	5,000	15,000
5	Low-noise amplifier	80 K	Two	20,000	40,000
6	Down converter		Three	9,000	27,000
7	Demodulator/decoder	Rate 1/2	Three	5,000	15,000
8	Shelter		One	10,000	10,000
9	Site		One	10,000	20,000
10	Site survey		One	25,000	25,000
11	Installation		One	20,000	20,000
12	Video modulator/demodulator		Two	10,000	20,000
13	Test equipment		One	10,000	10,000
14	Miscellaneous hardware		One	15,000	15,000
15	Uninterruptible power supply	20 kVA	One	36,000	36,000
	Total cost				470,000

4. Cost Summary (see Table E-4).

Table E-4. Cost summary

Item	Costs, dollars			
	Station 1	Station 2	Stations 3-7	Stations 8-14
Hardware processing	470,000	470,000	510,000 each	490,000 each
Hardware maintenance/yr	45,000	45,000	45,000 each	45,000 each
Personnel/yr	80,000	40,000	40,000 each	40,000 each
Space link data/yr	50,000		50,000 each	50,000 each
Space link video	\$1,400/h			

CONTINUED

2 OF 3

APPENDIX F
OTHER COST FACTORS

I. INTRODUCTION

This Appendix contains details on cost items appearing in the cost detail and backup sheets of Appendix I that are not covered elsewhere in this document. These items are one-time and recurring costs for facilities, operations recurring costs, and engineering costs.

II. FACILITIES COSTS

A. One-Time Costs

The one-time facilities cost includes the expenses incurred in preparing facilities for use. Facility costs include creation of prime and backup systems in separate rooms of the same building when redundancy is required. Facility preparation costs are assumed to be \$30.00/square foot.

Master switching facilities are sized at 1000 square feet. One master switcher for each option is considered. The one-time facility preparation cost for the master switcher in each option is, therefore, \$30,000.

Each regional switcher appearing in an option, in addition to the master switcher, is sized at 500 square feet for a one-time preparation cost of \$15,000 each.

B. Recurring Costs

Facility lease cost is assumed to be \$0.40/square foot/month. At this rate major switcher facility recurring costs are \$4,800/year for 1,000 square feet; and additional switcher facilities are \$2,400/year for each facility of 500 square feet. Item 2.3 in the recurring cost detail backup sheets of Appendix I show these costs as they apply to each option.

C. Uninterruptible Power Supplies

Uninterruptible power supplies (UPS) are provided at all regional and state switchers in all options to ensure commercial power continuity during momentary power transients as well as for extended periods.

Solid-state static inverter type UPS rated at 10 kVA were selected as appropriate for NALECOM use. These units include a rectifier/charger, static inverter, and autobypass switch at a total cost of \$13,000. Batteries for the unit are priced at \$2,500. The MTBF and MTTR for this UPS system is typically 45,000 and 1 h, respectively.

Gasoline engine generators, used when lengthy outages occur, include weatherproof housings and auto transfer switches that operate when commercial power fails. A 12-1/2-kW unit of this type is priced at \$4500.

The total one-time cost of the solid-state and engine units for each installation is \$20,000.

A maintenance contract can be negotiated to handle both UPS and engine generators for about \$6,000/year.

III. OPERATIONS RECURRING COSTS

Operations recurring costs are costs for personnel and travel required to maintain network operations. Personnel at major switcher centers and their estimated salaries are listed in Table F-1.

Each additional switcher location is manned with one person full time at a salary of \$17,000 annually. A travel allowance of \$2,000/year is allocated to each switcher location.

Item III in the recurring cost detail backup sheets of Appendix I specify operations recurring costs as they apply to each of the options.

IV. ENGINEERING COSTS

Engineering tasks applicable to all options were identified and classified into the categories listed in Table F-2.

Man-month estimates required to complete each of the tasks listed in Table F-2 for each option were made and totaled (see Table F-3).

The previously developed engineering cost of \$1,000,000 derived in Ref. 8 for the present option 7 phase a configuration was used as a baseline for engineering cost comparisons. Ratios of total engineering man-months required for each option to total months required for phase 7-a were derived, and the ratios applied to the \$1,000,000 phase 7-a baseline cost to determine engineering costs for each of the other options.

Table F-3 shows total estimated man-months and engineering costs for each option. For example, the ratio of total man-months for options 3 to phase 7-a of option 7 is $133/173 = 0.769$, resulting in an engineering cost for option 3 of $0.769 \times 1,000,000$ or \$769,000. Engineering costs for phases 7-b, 7-c, and 7-d are consistent with costs derived in Ref. 8.

For all options except 1 and 7, total engineering costs were distributed through the years 1975, 1976, and 1977 as:

1975: 50%
1976: 40%
1977: 10%

Table F-1. Personnel at major switcher centers

Personnel	Number required	Annual salary per person, dollars
Supervisor	1	20,000
Programmers	2	17,000
Computer operators	8	12,000

Table F-2. Engineering tasks

Task category	Task	Task category	Task
1	Final Functional Specifications	11	Switcher Testing
2	Final Guidelines	12	Network Test Plan
3	Switcher Design Specification/RFP	13	Network Checkout
4	NLETS Upgrade Specification/RFP	14	Network Design Specification
5	FDX Design (Protocol)	15	Network Manager
6	FDX/HDX Converter RFP	16	Operations Contract
7	Facilities RFP	17	Documentation
8	Line Procurement RFP	18	Network Deputy Manager
9	Facilities Fabrication Monitor	19	Supporting Analysis
10	Switcher Test Plan	20	User Requirements
		21	User Operators Manual

Table F-3. Total engineering man-hours and costs by option

Option	Man-months	Cost, dollars
1	143	809,000
2	138	798,000
3	133	769,000
4	168	1,000,000
5	210	1,213,000
6	249	1,439,000
7, phase a	173	1,000,000
8	216	1,248,000
9	237	1,370,000

Option 1 costs continue through 1978 because of upgrade requirements peculiar to option 1. Option 7 costs extend through 1978 as a result of the four implementation phases associated with the addition of satellite capability.

APPENDIX G
DELAY ANALYSIS

I. INTRODUCTION

Hard requirements for message delay were not identified during the NALECOM study. However, the goals established for design use are felt to be consistent with the desires of the Criminal Justice Community and consistent with response times of elements interfacing with the NALECOM Network.

The report on the Criminal Justice System (Ref. 7) in Standard Number 4.4 gave time requirements for Police Information System Response. These requirements are shown in Table G-1. Reference 2 suggests that NALECOM Network response times be no more than 5 to 10% of those given in Table G-1.

Table G-1. Response-time requirements

User	Maximum delay time
For users engaged in unpredictable field activity of high potential danger (e.g., vehicle stop)	120 s
For users engaged in field activity without exposure to high potential danger (e.g., checking parked vehicles)	5 min
For users engaged in investigatory activity without personal contact (e.g., developing suspect lists)	8 h
For users engaged in post-apprehension identification and criminal history determinations	4 h

II. NALECOM DELAY GOALS

NALECOM goals for priorities 1 and 2 used in the network designs in this report are to provide average response times less than or equal to 5% of the total response times given in Table G-1. The total response time includes an inquiry and a response. To simplify the design, only the one-way transmission of a message is considered, allowing one-half of the 5% for one-way time, or 2.5%.

This leads to NALECOM goals for average one-way transmission times between any two system terminations as follows:

- Priority 1: $0.025 \times 120 \text{ s} = 3 \text{ s}$
- Priority 2: $0.025 \times 300 \text{ s} = 7.5 \text{ s}$
- Priority 3: arbitrarily set at 30 s

The priority 3 requirement, although set somewhat arbitrarily, is reasonably consistent with priority 1 and 2 requirements. Priority 3 messages are generally long and multi-segmented. Total message transmission times fall at less than 10% of the total times given in Table G-1, last two items.

The goals are to be met for the worst routing in any given network. Average response times for all routings are considerably less. Also, worst-case values will be observed only at the end of the network life when traffic is at maximum levels.

In order to provide network designs which meet the delay goals, the following constraints on network configurations have been levied:

- a) Interfaces to system terminations will use communication lines with capacity equal to or greater than 2400 bps.
- b) Inter-region lines will be equal to or greater than 4800 bps. This ensures that inter-region connections, which may be through as many as three switching computers and two series communication lines, will not add a delay term greater than the equivalent of one 2400-bps line. That is, two 4800-bps lines in series are equivalent to one 2400-bps line.
- c) Line utilization, which is the fraction of time a line is in use (or not usable due to waiting for responses), is held to a maximum of 0.7.

III. DELAY CALCULATIONS

The worst possible link configuration in terms of maximum delay interconnecting one system termination to another is shown in Fig. G-1.

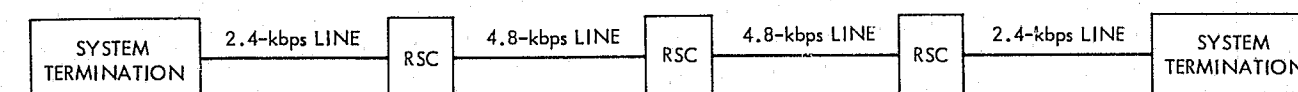

Fig. G-1. Worst link configuration

We will now calculate the average delay for this model assuming that utilization of each line in Fig. G-1 is at the maximum allowed. Any connection actually used in the network designs will provide delay values less than this upper limit, as actual line loadings do not fall at maximums. Service time distributions are assumed exponential. This assumption is conservative; therefore, actual delay values are less than calculations indicate. A link distance of 1000 mi is used for all calculations.

A. System Termination to Regional Switcher Delay

Message distributions for 1983 traffic as derived from Ref. 2 and from Appendix A are given in Table G-2. This distribution assumes that messages

Table G-2. State-to-RSC message characteristics

Routing	Priority level	Message per year, $\div 10^6$	Fraction of total messages	Characters per message
RSC to state	1	540	0.395	105
RSC to state	2	125	0.091	217
RSC to state	3	9	0.007	400
State to RSC	4	541	0.396	75
State to RSC	5	96	0.070	111
State to RSC	6	56	0.041	395
Totals		1367	1.0	118 (average)

longer than 400 characters are divided into separate 400-character messages. Six priority levels are shown. This is because, in the NLETS protocol, the switcher has master control of communication lines and outputs messages of any priority before allowing input from the state. Thus, state priority 1, 2, and 3 messages are actually priority levels 4, 5, and 6.

Service time (T_s) for the average message on state-to-RSC half-duplex links is calculated as:

$$T_s = \frac{(L + OH_1)8}{C} + \frac{NTA(PD)D}{100} + NPD$$

where

L = average message length in characters
= 118 characters

OH_1 = number of overhead characters used with each message for half-duplex link
= 34 for NLETS protocol

C = line capacity in bits per second
= 2400 bps in calculations

NTA = number of line turnarounds required for each message
= 5 for NLETS protocol

PD = propagation delay per 100 miles, in seconds
= 0.001 s/100 mi

D = distance in statute miles (assumed to be 1000 miles)

NPD = nodal processing delay, or time for computers to develop responses at each end of link, in seconds
= 0.006 s (from functional specifications)

The maximum message rate is:

$$n = \frac{\rho_{\max}}{T_s} = \frac{\rho_{\max}}{T_s}$$

where RHO_{\max} is maximum line utilization allowed (0.7). Utilization (ρ_i) for the i -th priority level is:

$$\rho_i = n_i T_{s_i}$$

where

n_i = number of messages/second at i -th level
= $n f_i$

T_{s_i} = service time for i -th level, calculated using formula for T_s previously given, using message length for i -th priority from Table G-2

f_i = fraction of messages at i -th level from Table G-2

Total delay for the average message at the i -th priority level, T_{q_i} is a sum of two components, waiting time (T_{w_i}) and service time (T_{s_i}). That is,

$$T_{q_i} = T_{s_i} + T_{w_i}$$

Assuming exponential distribution of service times, waiting time at the i -th priority level is:

$$T_{w_i} = \frac{n T_s^2}{\left(1 - \sum_{j=1}^{i-1} \rho_j\right) \left(1 - \sum_{j=1}^i \rho_j\right)}$$

By applying these calculations to the 2400-bps, 1000-mi link, the results given in Table G-3 can be obtained. By taking averages weighted by the number of messages, average service levels can be obtained for priority 1, 2, and 3 messages (see Table G-4).

Table G-3. State-to-RSC delay calculations

Priority level	Number of messages per second at i-th level	Service time for i-th level, s	Utilization for i-th level	Sum of waiting time and service time, s
1	0.49	0.519	0.254	1.05
2	0.113	0.893	0.101	1.71
3	0.009	1.05	0.014	2.46
4	0.491	0.419	0.206	1.88
5	0.087	0.539	0.047	2.99
6	0.051	1.49	0.076	4.93

Table G-4. Average delay for state-to-RSC links

Priority	Weighed average of priority levels (see Table G-3)	Average delay, s
1	1 and 4	1.47
2	2 and 5	2.27
3	3 and 6	4.57

B. Links Between RSCs

Links between RSCs operate using full-duplex protocol. Average service time for this protocol is:

$$T_s = \frac{(L + OH_2)^8}{C} + NPD$$

where

OH_2 = number of overhead characters
= 20

NPD = nodal processing delay, s
= 0.004 s

Maximum loading of full-duplex links allowed in topology calculations is at one-half of link capacity. Thus, for the links shown in Fig. G-1 using 4.8-kbps lines, loading is at 2400 bps maximum. This gives a maximum message rate as:

$$n = \frac{2400}{8L}$$

$$= \frac{2400}{8(118)} = 2.54 \text{ messages/second}$$

For inter-region traffic, message statistics are given in Table G-5. Only three priority levels apply as neither RSC exercises master control with full-duplex links. The average message length (L) is still 118 characters. Other than for service time (T_s) and message rate (n), calculations are the same as shown in Section III-A of this Appendix. Final delay values are given in Table G-6.

Table G-5. Inter-region message statistics

Priority level	Fraction of messages	Character per message
1	0.791	90
2	0.161	171
3	0.048	396

Table G-6. Delay values for inter-region links at 4800 bps

Priority level	Average delay, s
1	0.41
2	0.78
3	1.39

C. Delay Summations

We will now sum the delays for the total worst-case link given in Fig. G-1, using delay values calculated in Sections III-A and III-B of this Appendix. Figure G-2 repeats the link diagram giving a tabulation of delay values for each element. The overall end-to-end average delay, which is the summation of individual values, is given in Table G-7.

D. Worst-Case Delays for Each Option

Each network option has been examined to identify the worst link routing and subsequent delays calculated. The delay goals are met in all cases. Calculated values are given in the main report; calculation techniques are identical to those used in this Appendix.

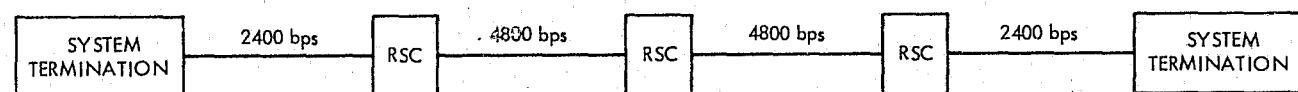

PRIORITY	DELAY VALUES BY LINK, s			
1	1.47	0.41	0.41	1.47
2	2.27	0.78	0.78	1.27
3	4.57	1.39	1.39	4.57

Fig. G-2. Worst-case link delay values

Table G-7. Total delays for worst link

Priority	Total average delay, s
1	3.76
2	6.1
3	11.92

APPENDIX H
AVAILABILITY ANALYSIS

I. AVAILABILITY

This Appendix gives background data on the techniques and parameter values used for network availability analysis.

Availability is the average fraction of time that a system or part of a system can be expected to be operational. It is the ratio of the average or mean time between failures (MTBF) and the sum of the MTBF and mean time to repair (MTTR), i. e.,

$$A = \frac{MTBF}{MTBF + MTTR}$$

Availability calculations for a system are only as good as the availability values used for the system components. Parameters used in the NALECOM computations have been selected using information from experience in other networks of similar configuration, from manufacturers' data and conservative engineering estimates.

A. Availability Goals

The goal for availability used in the network options is that availability of any specific routing from any one system termination to any other should be equal to or less than 0.993. This implies an outage of less than 10 min per day. ("Outage" means complete disconnection, i. e., if a connection between two network nodes is through two parallel communication lines, the two nodes are considered connected if only one line is operational.) In some cases of network operation, this may mean that during outages, only priority 1 or priority 1 and 2 messages can be processed.

Availability calculations are made only for NALECOM Network components, not considering the state computers. The end point for calculations is either the modem at the state or a state switching computer supplied by the NALECOM Network in multi-switcher options 6 and 9.

Compliance with availability goals is developed by using redundancy at network locations where outage of a network element would cause more than one system termination to be disconnected. In addition, connections to the NCIC are redundant, as loss of this connection would cause loss of access to an extremely important data base. Also, all switching computers can be accessed by two routes; i. e., they are two-connected.

B. Availability Calculations

Availability calculations used follow the techniques shown in Figs. H-1 and H-2, where A_i is the availability of the i -th element. In the case of the two parallel elements (Fig. H-2) the total availability is one minus the probability that both elements are unavailable.

Table H-1 lists the availability values used in network calculations. These values are used in Figs. H-3 and H-4 to calculate availability for the redundant RSC computers and non-redundant SSC computer.

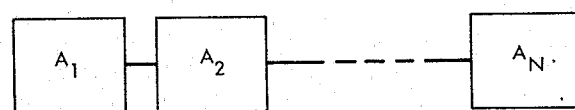

$$A_{TOTAL} = A_1 \times A_2 \times \dots \times A_N$$

Fig. H-1. Availability calculations for series element

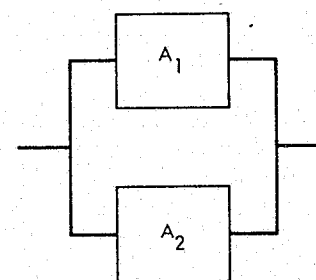

$$A_{TOTAL} = [1 - (1 - A_1)(1 - A_2)]$$

Fig. H-2. Availability calculation for two parallel elements

Table H-1. Availability estimates

Item	Description	Availability	Source
1	Modem	0.9988	MTBF = 5000 h MTTR = 6 h
2	Line + two modems	0.996	JPL TR 32-1526 XIX 4800-bps lines
3	Computer, non-redundant including two line interfaces	0.997	Calculated from items 7 and 8
4	Commercial power at RSC	0.967	Assuming down time 1 day/month
5	Backup power at RSC	0.995	MTBF = 2000 h MTTR = 10 h
6	Communication line only	0.9984	Calculated from items 1 and 2
7	Line interface	0.9992	MTBF = 8000 h MTTR = 6 h
8	Computer, non-redundant, excluding line interfaces	0.9986	MTBF = 6000 h MTTR = 8 h
9	Dialup communication line	0.995	Assumes 5-min dialup time plus availability of item 6

C. Availability Calculations by Network Option

Figures H-5 through H-8 give the worst network connection configurations for all options considered and show the calculations of availability for each configuration. These availability calculations are summarized in Table H-2. Although calculated values are slightly below the goals, they are considered acceptable, as the goal was an estimate only and actual values are close to the goal. Availability can be easily improved with low cost by adding dialup lines or redundant elements at critical points. Availability values are so close for all options that it is not considered to be a major factor in option selection.

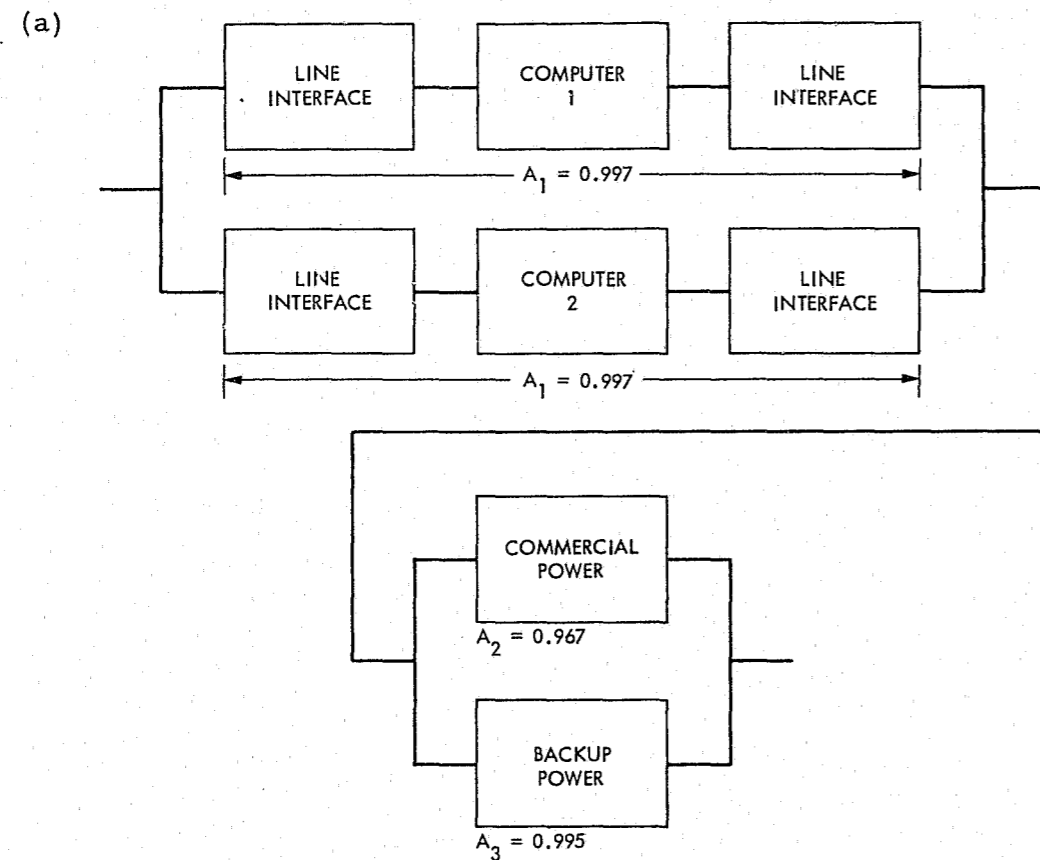

(b)

$$\begin{aligned}
 ARSC &= [1 - (1 - A_1)^2] [1 - (1 - A_2)(1 - A_3)] \\
 &= [1 - (1 - 0.997)^2] [1 - (1 - 0.967)(1 - 0.995)] \\
 &= 0.99999 (0.9998) \\
 &= 0.9998
 \end{aligned}$$

Fig. H-3. Availability calculation for redundant RSC computer.
 (a) Availability block diagram. (b) Total availability calculation.

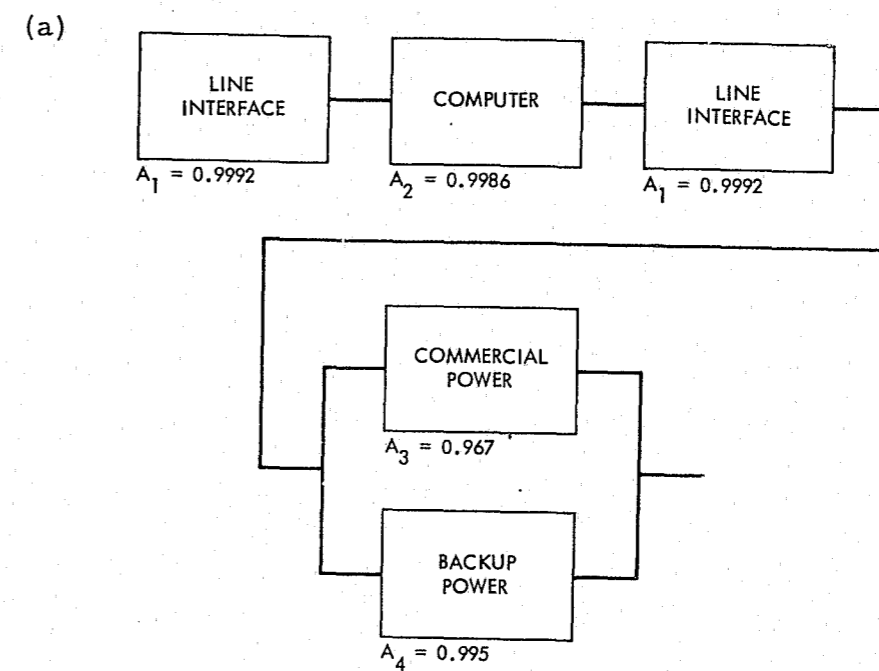

(b)

$$\begin{aligned}
 A_{SSC} &= A_1^2 A_2 \{1 - [1 - (1 - A_3)(1 - A_4)]\} \\
 &= 0.9992^2 (0.9986) [1 - (1 - 0.967)(1 - 0.995)] \\
 &= 0.9968
 \end{aligned}$$

Fig. H-4. Availability calculation for non-redundant SSC computer.
 (a) Availability block diagram. (b) Total availability calculation.

Table H-2. Availability summary

Option	Worst-case availability	Average disconnect per day, min
1	0.9918	11.8
2	0.9918	11.8
3	0.9918	11.8
4	0.9916	12.1
5	0.9915	12.2
6	0.989	15.8
7	0.9916	12.1
8	0.9915	12.2
9	0.989	15.8

The availability number for option 6 applies only to the worst connections to Alaska and Hawaii. Worst availability in CONUS is 0.993. Worst-case availability shown for option 9 applies only to Alaska, Hawaii, and Nevada. Next worst availability is 0.9915.

II. CONCLUSIONS

Although availability values fall slightly outside the goal, they are considered acceptable. With minor cost increases redundancy could be added at critical points, bringing availability within goals.

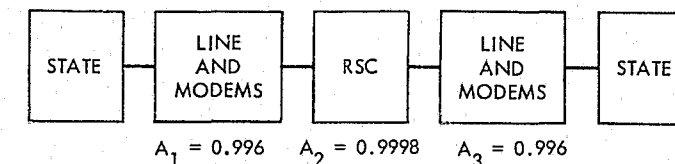

$$A_{TOTAL} = (0.996)(0.9998)(0.996) = 0.9913$$

Fig. H-5. Availability for options 1, 2, and 3

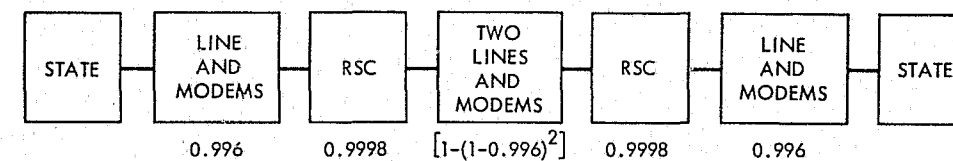

$$AVAILABILITY: 0.996 \quad 0.9998 \quad [1 - (1 - 0.996)^2] \quad 0.9998 \quad 0.996$$

$$A_{TOTAL} = (0.996)^2 (0.9998)^2 [1 - (1 - 0.996)^2] = 0.9916$$

Fig. H-6. Availability for options 4 and 7

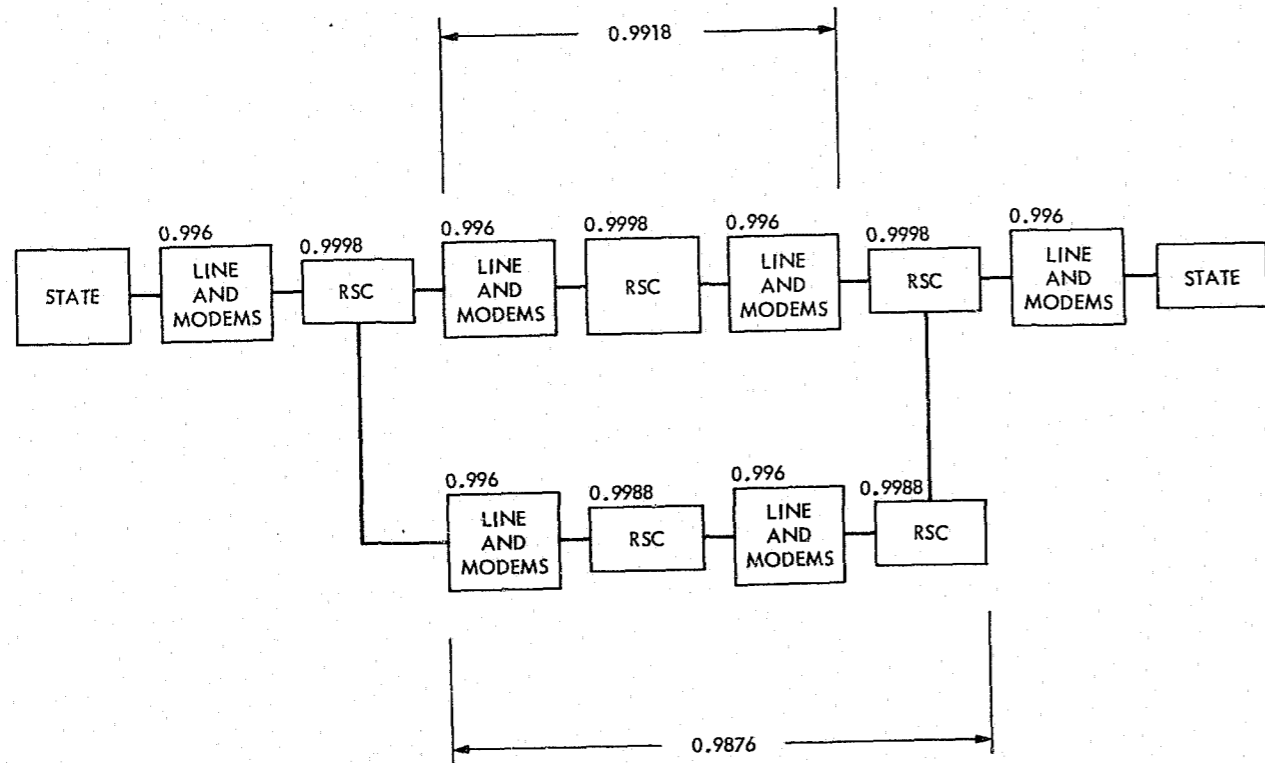

$$A_{TOTAL} = (0.996)^2 (0.9998)^2 [1 - (1 - 0.9918)(1 - 0.9876)]$$

$$= 0.9915$$

Fig. H-7. Availability for options 5 and 8

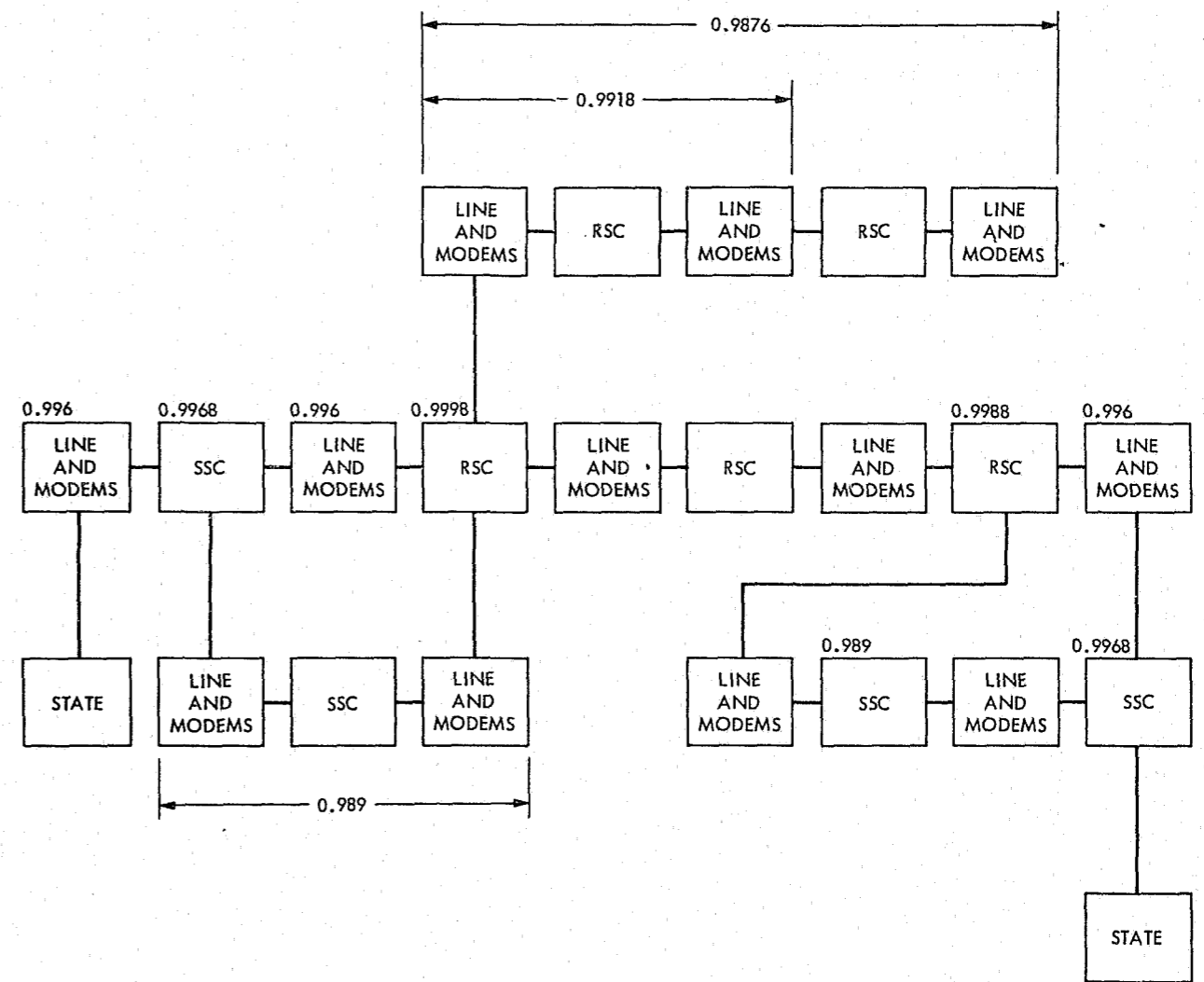

$$A_{TOTAL} = (0.996) (0.9968)^2 [1 - (1 - 0.996)(1 - 0.989)]^2 (0.9998)^2 [1 - (1 - 0.9876)(1 - 0.9918)]$$

$$= (0.996) (0.9936) (0.9999) (0.9996) (0.9999)$$

$$= 0.989$$

Fig. H-8. Availability for options 6 and 9

APPENDIX I
COST DETAIL BACKUP

I. COST-DETAIL BACKUP SHEETS

This Appendix contains cost-detail backup sheets for the data presented for each option considered in Section V of this publication. There are detail backup sheets for one-time costs and for recurring costs for each network configuration. These sheets expand on the cost-detail sheets in Section V and provide a deeper understanding of specific hardware, software, facilities, and operational cost considerations for each option.

Included in Appendix I are cost detail and cost-detail backup sheets for the minimum traffic analyses conducted for options 3 and 4.

COST DETAILS

OPTION 1

NUMBER OF REGIONS: Two

SWITCHER LOCATIONS: Phoenix and D.C.

REMARKS: Separate State and National Networks Without Multiplexing:
D. C. One-Time Costs

I. ONE-TIME COSTS

Item	Description	Unit Cost, K\$	Number Required	Total Cost, K\$	Installation Plan by Year of Installation		Item Subtotals
					1976	1979	
1.1	Communication Lines	-	-		14.2	15.0	29.2
1.2	Hardware						652.6
	a. Basic Computer	80.7	2	161.4	161.4		
	b. OPS Center	44.6	1	44.6	44.6		
	c. FDX Converter						
	d. Line Interfaces	-	-	446.6	446.6		
	e. Microwave						
	f. Ground Stations						
1.3	Computer Software	294	1	294	294		294
	a. RSCs						
	b. FDX Converter						
1.4	Facilities						50
	a. Floor Space						
	Region 1 1000 ft ²	30	1	30	30		
	Region 2-n 500 ft ² each	15	0	0	0		
	b. Backup Power (UPS)	20	1	20	20		
TOTALS							

COST DETAIL

OPTION 1

REMARKS: National Traffic: D. C. Recurring Costs

II. RECURRING COSTS, K\$

Item	Description	Pre-1980			1980-1983			Item Subtotals
		Annual Cost (Each)	Number Re-quired	Total Annual	Annual Cost (Each)	Number Re-quired	Total Annual	
2.1	a. Communication Lines	-	-	563.7	-	-	657.5	563.7 657.5
	b. Space Link							
2.2	Hardware							94.7 110.3
	a. Basic Computer	9.9	2	19.8	9.9	2	19.8	
	b. Line Interfaces	-	-	68.9	-	-	84.5	
	c. OPS Center	6	1	6.0	6	1	6.0	
	d. Microwave							
	e. Ground Station							
2.3	Facilities							10.8
	a. Floor Space							
	Region 1	4.8	1	4.8	4.8	1	4.8	
	Region 2-n	0	0	0	0	0	0	
	b. Backup Power	6	1	6.0	6	1	6.0	
III. OPERATIONS								99
	a. Region 1							
	Supervisor	20	1	20	20	1	20	
	Programmers	17	1	17	17	2	17	
	Operators	12	5	60	12	8	60	
	Travel	2	1	1	2	1	2	
	b. Region 2-n							
	Operators	17	0	0	0	0	0	
	Travel	2	0	0	0	0	0	
TOTALS								

COST DETAILS

OPTION 1

NUMBER OF REGIONS: Two

SWITCHER LOCATIONS: Phoenix and D.C.

REMARKS: Separate State and National Networks Without Multiplexing:
Phoenix One-Time Costs

I. ONE-TIME COSTS

Item	Description	Unit Cost, K\$	Number Required	Total Cost, K\$	Installation Plan by Year of Installation		Item Subtotals	
					1976	1977		
1.1	Communication Lines	-	-		12.75	0.75	12.75	0.75
1.2	Hardware							
	a. Basic Computer				0	90.0		
	b. OPS Center (Line Printer)	23	1	23		23.0		
	c. FDX Converter							
	d. Line Interfaces			(1) 168.0	168.0			
	e. Microwave							
	f. Ground Stations						168	113
1.3	Computer Software				0	30.0		
	a. RSCs							30
	b. FDX Converter							
1.4	Facilities							
	a. Floor Space							
	Region 1 1000 ft ²	30	1	30	30			
	Region 2-n 500 ft ² each	15	0	0	0			
	b. Backup Power (UPS)	20	1	20	20			
TOTALS: (1) 28 additional line interface units at \$6,000 each.							50	

COST DETAILS

OPTION 1

REMARKS: State Traffic: Phoenix Recurring Costs

II. RECURRING COSTS, K\$

Item	Description	Pre-1978			1978-1983			Item Subtotals		
		Annual Cost (each)	Number Re-quired	Total Annual	Annual Cost (each)	Number Re-quired	Total Annual			
2.1	a. Communication Lines			670			678.3	670	678.3	
	b. Space Link									
2.2	Hardware									
	a. Basic Computer			(1) 24			30			
	b. Line Interfaces			(2)			(2)			
	c. OPS Center				1.1	1	1.1			
	d. Microwave									
	e. Ground Station							24	31.1	
2.3	Facilities									
	a. Floor Space									
	Region 1	4.8	1	4.8	4.8	1	4.8			
	Region 2-n	0	0	0	0	0	0			
	b. Backup Power	6	1	6.0	6	1	6.0			
									10.8	10.8
III. OPERATIONS										
	a. Region 1									
	Supervisor	20	1	20	20	1	20			
	Programmers	17	1	17	17	1	17			
	Operators	12	3	36	12	3	36			
	Travel	2	1	2	2	1	2			
	b. Region 2-n									
	Operators	17	0	0	17	0	0			
	Travel	2	0	0	2	0	0			
									55	
TOTALS										
(1) Source: NLETS. (2) Included in item 2.2a.										

COST DETAILS

OPTION 2

NUMBER OF REGIONS: One

SWITCHER LOCATIONS: Phoenix

REMARKS: With NLETS Upgrade and FDX to NCIC

I. ONE-TIME COSTS

Item	Description	Unit Cost, K\$	Number Required	Total Cost, K\$	Installation Plan by Year of Installation		Item Subtotals
					1976	1979	
1.1	Communication Lines	-	-	37.8	19	18.8	38
1.2	Hardware						1124
	a. Basic Computer	260	2	520	520		
	b. OPS Center	19	1	19	19		
	c. FDX Converter	44	1	44	44		
	d. Line Interfaces	15.5		541	541		
	e. Microwave						
	f. Ground Stations						
1.3	Computer Software	0	0 ⁽¹⁾	0	0		40
	a. RSCs						
	b. FDX Converter	40	1	40	40		
1.4	Facilities						50
	a. Floor Space						
	Region 1 1000 ft ²	30	1	30	30		
	Region 2-n 500 ft ² each	15	0	0			
	b. Backup Power (UPS)	20	1	20	20		
TOTALS: ⁽¹⁾ Included in item 1.2.							

COST DETAILS

OPTION 2

REMARKS: NLETS Upgrade

II. RECURRING COSTS, K\$

Item	Description	Pre-1980			1980-1983			Item Subtotals
		Annual Cost (Each)	Number Required	Total Annual	Annual Cost (Each)	Number Required	Total Annual	
2.1	a. Communication Lines	-	-	787.4	-	-	1012.7	
	b. Space Link		0			0		
2.2	Hardware							101 101
	a. Basic Computer	23.4	2	46.8	23.4	2	46.8	
	FDX Converter	4	1	4	4	1	4	
	b. Line Interfaces	1.4		48.7	1.4		48.7	
	c. OPS Center	1.9	1	1.9	1.9	1	1.9	
	d. Microwave		0			0		
	e. Ground Station							
2.3	Facilities							11
	a. Floor Space							
	Region 1	4.8	1	4.8	4.8	4.8	4.8	
	Region 2-n	0	0	0	0	0	0	
	b. Backup Power	6	1	6	6	1	6	
III. OPERATIONS								
	a. Region 1							152
	Supervisor	20	1	20	20	1	20	
	Programmers	17	2	34	17	2	34	
	Operators	12	8	96	12	8	96	
	Travel	2	1	2	2	1	2	
	b. Region 2-n							
	Operators	17	0	0	0	0	0	
	Travel	2	0	0	0	0	0	
TOTALS								

COST DETAILS

OPTION 2

NUMBER OF REGIONS: One

SWITCHER LOCATIONS: PHX

REMARKS: FDX to NCIC and New Computer at Phoenix

I. ONE-TIME COSTS

Item	Description	Unit Cost, K\$	Number Required	Total Cost, K\$	Installation Plan by Year of Installation		Item Subtotals
					1976	1979	
1.1	Communication Lines	-	-	37.8	19	18.8	37.8
1.2	Hardware						870.9
	a. Basic Computer	80.7	2	161.4	161.4	0	
	b. OPS Center	-	-	44.6	44.6	0	
	c. FDX Converter	44.0	1	44.0	44.0		
	d. Line Interfaces	-	-	620.9	620.9	0	
	e. Microwave						
1.3	Computer Software	294	1	294	294		334.0
	a. RSCs						
	b. FDX Converter	40	1	40	40		
1.4	Facilities						50
	a. Floor Space						
	Region 1 1000 ft ²	30	1	30	30		
	Region 2-n 500 ft ² each	15	0	0			
	b. Backup Power (UPS)	20	1	20	20		
TOTALS							

COST DETAILS

OPTION 2

REMARKS: New Computer at Phoenix

II. RECURRING COSTS, K\$

Item	Description	Pre-1980			1980-1983			Item Subtotals
		Annual Cost (Each)	Number Required	Total Annual	Annual Cost (Each)	Number Required	Total Annual	
2.1	a. Communication Lines			787.4			1012.7	
	b. Space Link							
2.2	Hardware							105.4 127.7
	a. Basic Computer	9.9	2	19.8	9.9	2	19.8	
	FDX Converter	4.0	1	4.0	4.0	1	4.0	
	b. Line Interfaces	-	-	75.6	-	-	97.9	
	c. OPS Center	6	1	6.0	6	1	6.0	
	d. Microwave							
2.3	e. Ground Station							10.8
	Facilities							
	a. Floor Space							
	Region 1	4.8	1	4.8	4.8	1	4.8	
Region 2-n	0	0	0	0	0	0		
	b. Backup Power	6	1	6.0	6	1	6.0	
III. OPERATIONS								152
	a. Region 1							
	Supervisor	20	1	20	20	1	20	
	Programmers	17	2	34	17	2	34	
	Operators	12	8	96	12	8	96	
Travel	2	1	2	2	1	2		
	b. Region 2-n							
Operators	17	0	0	17	0	0	0	
Travel	2	0	0	2	0	0	0	
TOTALS								

COST DETAILS

OPTION 3

NUMBER OF REGIONS: One

SWITCHER LOCATIONS: One switcher at D.C.

REMARKS: _____

I. ONE-TIME COSTS

Item	Description	Unit Cost, K\$	Number Required	Total Cost, K\$	Installation Plan by Year of Installation		Item Subtotals
					1976	1979	
1.1	Communication Lines	-	-	-	15.3	16.0	31.3
1.2	Hardware						759.0
	a. Basic Computer	80.7	2	161.4	161.4		
	b. OPS Center	44.6	1	44.6	44.6		
	c. FDX Converter						
	d. Line Interfaces	-	-	553.0	553.0		
	e. Microwave						
	f. Ground Stations						
1.3	Computer Software	294.0	1	294.0	294.0		294.0
	a. RSCs						
	b. FDX Converter						
1.4	Facilities						50
	a. Floor Space						
	Region 1 1000 ft ²	30	1	30	30		
	Region 2-n 500 ft ² each	15	0	0	0		
	b. Backup Power (UPS)	20	1	20	20		
TOTALS							1134

COST DETAILS

OPTION 3

REMARKS: One Switcher at D.C.

II. RECURRING COSTS, K\$

Item	Description	Pre-1980			1980-1983			Item Subtotals
		Annual Cost (Each)	Number Required	Total Annual	Annual Cost (Each)	Number Required	Total Annual	
2.1	a. Communication Lines	-	-	568.0	-	-	686.2	568 686.2
	b. Space Link							
2.2	Hardware							95.8 111.4
	a. Basic Computer	9.9	2	19.8	9.9	2	19.8	
	b. Line Interfaces	-	-	70.0	-	-	85.6	
	c. OPS Center	6.0	1	6.0	6.0	1	6.0	
	d. Microwave							
	e. Ground Station							
2.3	Facilities							10.8
	a. Floor Space							
	Region 1	4.8	1	4.8	4.8	1	4.8	
	Region 2-n	0	0	0	0	0	0	
	b. Backup Power	6	1	6	6	1	6	
III. OPERATIONS								
	a. Region 1							152.0
	Supervisor	20	1	20	20	1	20	
	Programmers	17	2	34	17	2	34	
	Operators	12	8	96	12	8	96	
	Travel	2	1	2	2	1	2	
	b. Region 2-n							
Operators	17	0	0	0	0	0	0	
Travel	2	0	0	0	0	0	0	
TOTALS							152.0	

COST DETAILS

OPTION 3

REMARKS: Minimum Traffic: Without Multiplexing

Item	Calendar Year									
	1975	1976	1977	1978	1979	1980	1981	1982	1983	Total
I. One-Time Costs										
1.1. Lines		15	-	-	15	-	-	-	-	30
1.2. Computer Hardware		746	-	-	-	-	-	-	-	746
1.3. Computer Software		294	-	-	-	-	-	-	-	294
1.4. Facilities		50	-	-	-	-	-	-	-	50
II. Recurring Costs										
2.1. Lines			559	559	559	662	662	662	662	4325
2.2. Switchers			94	94	94	109	109	109	109	718
2.3. Facilities			11	11	11	11	11	11	11	77
III. Operating Personnel			152	152	152	152	152	152	152	1064
IV. Engineering		385	307	77						769
Annual Subtotals		1490	1123	893	831	934	934	934	934	
Overall Total										8073
Option 3, Normal Traffic Without Multiplexing										8225
Difference										152
% Difference										1.8

COST DETAILS

OPTION 3

NUMBER OF REGIONS: One

SWITCHER LOCATIONS: D.C.

REMARKS: Minimum Traffic Analysis

I. ONE-TIME COSTS

Item	Description	Unit Cost, K\$	Number Required	Total Cost, K\$	Installation Plan by Year of Installation		Item Subtotals
					1976	1979	
1.1	Communication Lines	-	-		14.9	14.8	30
1.2	Hardware						746
	a. Basic Computer	80.7	2	161.4	161.4		
	b. OPS Center	44.6	1	44.6	44.6		
	c. FDX Converter						
	d. Line Interfaces	-	-	540	540		
	e. Microwave						
	f. Ground Stations						
1.3	Computer Software						294
	a. RSCs	294	1	294			
	b. FDX Converter						
1.4	Facilities						50
	a. Floor Space						
	Region 1 1000 ft ²	30	1	30	30		
	Region 2-n 500 ft ² each	15	0	0	0		
	b. Backup Power (UPS)	20	1	20	20		
TOTALS							

COST DETAILS

OPTION 3

REMARKS: Minimum Traffic Analysis

II. RECURRING COSTS, K\$

Item	Description	Pre-1980			1980-1983			Item Subtotals
		Annual Cost (Each)	Number Required	Total Annual	Annual Cost (Each)	Number Required	Total Annual	
2.1	a. Communication Lines	-	-	559	-	-	662	559 662
	b. Space Link							
2.2	Hardware							94 109
	a. Basic Computer	9.9	2	19.8	9.9	2	19.8	
	b. Line Interfaces	-	-	68	-	-	83	
	c. OPS Center	6	1	6	6	1	6	
	d. Microwave							
e. Ground Station								
2.3	Facilities							11
	a. Floor Space							
	Region 1	4.8	1	4.8	4.8	1	4.8	
	Region 2-n	0	0	0	0	0	0	
b. Backup Power	6	1	6	6	1	6		
III. OPERATIONS								
	a. Region 1							152
	Supervisor	20	1	20	20	1	20	
	Programmers	17	2	34	17	2	34	
	Operators	12	8	96	12	8	96	
	Travel	2	1	2	2	1	2	
	b. Region 2-n							
	Operators	17	0	0	17	0	0	
	Travel	2	0	0	2	0	0	
TOTALS								

COST DETAILS

OPTION 4

NUMBER OF REGIONS: Two

SWITCHER LOCATIONS: D.C. and Phoenix

REMARKS: New Computers at Both Switchers

I. ONE-TIME COSTS

Item	Description	Unit Cost, K\$	Number Required	Total Cost, K\$	Installation Plan by Year of Installation		Item Subtotals
					1976	1979	
1.1	Communication Lines	-			15.65	14.6	30.2
1.2	Hardware	3 46.0	2	92		92	912.6
	a. Basic Cmptr 52	80.7	2	161.4		161.4	
	b. OPS Center	44.6	1	44.6			
	c. FDX Converter						
	d. Line Interfaces	-	-	614.6			
	e. Microwave						
f. Ground Stations							
1.3	Computer Software	294	1	294			294.0
	a. RSCs						
b. FDX Converter							
1.4	Facilities						85
	a. Floor Space						
	Region 1 1000 ft ²	30	1	30			
	Region 2-n 500 ft ² each	15	1	15			
b. Backup Power (UPS)	20	2	40				
TOTALS							

COST DETAILS

OPTION 4

REMARKS: New Computers at D.C. and Phoenix

II. RECURRING COSTS, K\$

Item	Description	Pre-1980			1980-1983			Item Subtotal
		Annual Cost (Each)	Number Required	Total Annual	Annual Cost (Each)	Number Required	Total Annual	
2.1	a. Communication Lines	-	-	461.12	-	-	576.56	
	b. Space Link							
2.2	Hardware							111.6 129.6
	a. Basic Computer	4.9	2	9.8	4.9	2	9.8	
		9.9	2	19.8	9.9	2	19.8	
	b. Line Interfaces	-	-	76	-	-	94	
	c. OPS Center	6	1	6	6	1	6	
	d. Microwave							
2.3	Facilities							19.2
	a. Floor Space Region 1	4.8	1	4.8	4.8	1	4.8	
	Region 2-n	2.4	1	2.4	2.4	1	2.4	
	b. Backup Power	6	2	12.0	6	2	12.0	
III. OPERATIONS:								
	a. Region 1 Supervisor	20	1	20	20	1	20	171
	Programmers	17	2	34	17	2	34	
	Operators	12	8	96	12	8	96	
	Travel	2	1	2	2	1	2	
	b. Region 2-n Operators	17	1	17	17	1	17	
	Travel	2	1	2	2	1	2	
TOTALS								

COST DETAILS

OPTION 4

NUMBER OF REGIONS: Two

SWITCHER LOCATIONS: D.C. and Phoenix

REMARKS: With NLETS Upgrade and New Computer at D.C.

I. ONE-TIME COSTS

Item	Description	Unit Cost, K\$	Number Required	Total Cost, K\$	Installation Plan by Year of Installation		Item Subtotals
					1976	1979	
1.1	Communications Lines	-	-	-	15.65	14.6	30.2
1.2	Hardware	3 180	2	360	360		1104
	a. Basic Cmptr	52 80.7	2	161.4	161.4		
	b. OPS Center		1	44.6	44.6		
	c. FDX Converter						
	d. Line Intrfc	52 -	52	385	385		
	e. Microwave	3 6.0	16	96	96		
	f. Ground Stations		6	57	57		
1.3	Computer Sftw	52 294	1	294	294	0	294
	a. RSCs	3 0	0	0	① a		
	b. FDX Converter						
1.4	Facilities						85
	a. Floor Space Region 1	1000 ft ²	30	1	30	30	
	Region 2-n	500 ft ² each	15	1	15	15	
	b. Backup Power (UPS)		20	2	40	40	
TOTALS: ① Included in item 1.2a.							

COST DETAILS

OPTION 4

REMARKS: Using NLETS Upgrade

II. RECURRING COSTS \$

Item	Description	Pre-1980			1980-1983			Item Subtotals	
		Annual Cost (Each)	Number Required	Total Annual	Annual Cost (Each)	Number Required	Total Annual		
2.1	a. Communication Lines			461			577	461 577	
	b. Space Link								
2.2	Hardware 52	9.9	2	19.8	9.9	2	19.8		
	a. Basic Computer 3	16.2	2	32.4	16.2	2	32.4		
		0.54	16	8.6	0.54	16	8.6		
		3 0.36	34	12.2	0.36	34	12.2		
	b. Line Interfaces	0.855	6	5.1	0.855	6	5.1		
		52 -	41	49.0	-	52	61.0		
	c. OPS Center	6	1	6	6	1	6		
d. Microwave									
e. Ground Station									
2.3	Facilities							19.2	
	a. Floor Space								
		Region 1	4.8	1	4.8	4.8	1		4.8
	Region 2-n	2.4	1	2.4	2.4	1	2.4		
b. Backup Power	6	2	12.0	6	2	12.0			
III. OPERATIONS:									
	a. Region 1	Supervisor	20	1	20	20	1	20	171
		Programmers	17	2	34	17	2	34	
		Operators	12	8	96	12	8	96	
		Travel	2	1	2	2	1	2	
	b. Region 2-n	Operators	17	1	17	1	17	17	
		Travel	2	1	2	2	1	2	
TOTALS									

COST DETAILS

OPTION 4

REMARKS: Minimum Traffic: New Computers

Item	Calendar Year									
	1975	1976	1977	1978	1979	1980	1981	1982	1983	Total
I. One-Time Costs										
1.1. Lines		15	-	-	13	-	-	-	-	28
1.2. Computer Hardware		886	-	-	-	-	-	-	-	886
1.3. Computer Software		294	-	-	-	-	-	-	-	294
1.4. Facilities		85	-	-	-	-	-	-	-	85
II. Recurring Costs										
2.1. Lines			435	435	435	533	533	533	533	3437
2.2. Switchers			107	107	107	125	125	125	125	821
2.3. Facilities			19	19	19	19	19	19	19	133
III. Operating Personnel			171	171	171	171	171	171	171	1197
IV. Engineering	500	400	100							1000
Annual Subtotals	500	1680	832	732	745	848	848	848	848	
Overall Total										7881
Option 4: Normal Traffic										8193
Difference										312
% Difference										4.0

COST DETAILS

OPTION 4

NUMBER OF REGIONS: Two

SWITCHER LOCATIONS: D.C. and Phoenix

REMARKS: Minimum Traffic: New Computers

I. ONE-TIME COSTS

Item	Description	Unit Cost, K\$	Number Required	Total Cost, K\$	Installation Plan by Year of Installation		Item Subtotals
					1976	1979	
1.1	Communication Lines			28	14.6	13	28
1.2	Hardware						886.4
	a. Basic Computer	46.0	2	92			
	b. OPS Center	80.7	2	161.4			
	c. FDX Converter	44.6	1	44.6			
	d. Line Interfaces	-	-	588.4			
	e. Microwave						
1.3	Computer Software						294
	a. RSCs	294	1	294			
	b. FDX Converter						
1.4	Facilities						85
	a. Floor Space						
	Region 1 1000 ft ²	30	1	30			
	Region 2-n 500 ft ² each	15	1	15			
b. Backup Power (UPS)	20	2	40				
TOTALS							

COST DETAILS

OPTION 4

REMARKS: Minimum Traffic: New Computers

II. RECURRING COSTS, K\$

Item	Description	Pre-1980			1980-1983			Item Subtotals
		Annual Cost (Each)	Number Required	Total Annual	Annual Cost (Each)	Number Required	Total Annual	
2.1	a. Communication Lines	-	-	434.7	-	-	532.9	435 533
	b. Space Link							
2.2	Hardware							107 125
	a. Basic Computer	4.9	2	9.8	4.9	2	9.8	
		9.9	2	19.8	9.9	2	19.8	
	b. Line Interfaces	-	-	71.3	-	-	89.1	
	c. OPS Center	6	1	6	6	1	6	
	d. Microwave							
2.3	Facilities							19.2
	a. Floor Space							
	Region 1	4.8	1	4.8	4.8	1	4.8	
	Region 2-n	2.4	1	2.4	2.4	1	2.4	
	b. Backup Power	6	2	12.0	6	2	12.0	
III. OPERATIONS								
	a. Region 1							171
	Supervisor	20	1	20	20	1	20	
	Programmers	17	2	34	17	2	34	
	Operators	12	8	96	12	8	96	
	Travel	2	1	2	2	1	2	
	b. Region 2-n							
	Operators	17	1	17	17	1	17	
	Travel	2	1	2	2	1	2	
TOTALS								

COST DETAILS

OPTION 5

NUMBER OF REGIONS: Five

SWITCHER LOCATIONS: Five Switchers

REMARKS: _____

I. ONE-TIME COSTS

Item	Description	Unit Cost, K\$	Number Required	Total Cost, K\$	Installation Plan by Year of Installation		Item Subtotals
					1976	1979	
1.1	Communication Lines	-	-	33.4	18.1	15.3	33.4
1.2	Hardware						1368.4
	a. Basic Computer	46	10	460	460		
	b. OPS Center	44.6	1	44.6	44.6		
	c. FDX Converter						
	d. Line Interfaces	-	-	863.8	863.8		
	e. Microwave						
1.3	Computer Software	294	1	294	294		294.0
	a. RSCs						
	b. FDX Converter						
1.4	Facilities						190.0
	a. Floor Space						
	Region 1 1000 ft ²	30	1	30	30		
	Region 2-n 500 ft ² each	15	4	60	60		
	b. Backup Power (UPS)	20	5	100	100		
TOTALS							1885.8

COST DETAILS

OPTION 5

REMARKS: Five Switchers

II. RECURRING COSTS, K\$

Item	Description	Pre-1980			1980-1983			Item Subtotals
		Annual Cost (Each)	Number Required	Total Annual	Annual Cost (Each)	Number Required	Total Annual	
2.1	a. Communication Lines	-	-	421.6	-	-	503	421.6 503
	b. Space Link							
2.2	Hardware							150 178.6
	a. Basic Computer	4.9	10	49	4.9	10	49	
	b. Line Interfaces	-	-	95	-	-	123.6	
	c. OPS Center	6	1	6	6	1	6	
	d. Microwave							
	e. Ground Station							
2.3	Facilities							44.4
	a. Floor Space							
	Region 1	4.8	1	4.8	4.8	1	4.8	
	Region 2-n	2.4	4	9.6	2.4	4	9.6	
	b. Backup Power	6	5	30.0	6	5	30.0	
III. OPERATIONS:								
	a. Region 1							228
	Supervisor	20	1	20	20	1	20	
	Programmers	17	2	34	17	2	34	
	Operators	12	8	96	12	8	96	
	Travel	2	1	2	2	1	2	
	b. Region 2-n							
	Operators	17	4	68	17	4	68	
Travel	2	4	8	2	4	8		
TOTALS								

COST DETAILS

OPTION 6

NUMBER OF REGIONS: 50

SWITCHER LOCATIONS: 50 Switchers

REMARKS: _____

I. ONE-TIME COSTS

Item	Description	Unit Cost, K\$	Number Required	Total Cost, K\$	Installation Plan by Year of Installation		Item Subtotals
					1976	1979	
1.1	Communication Lines	-	-	35	25	10	35
1.2	Hardware	46	10	460			
	a. Basic Computer	46	45	2070	2530		
	b. OPS Center	44.6	1	44.6	47		
	c. FDX Converter						
	d. Line Interfaces	-	-	1163	1163		
	e. Microwave						
1.3	Computer Software	340	1	340			340
	a. RSCs						
	b. FDX Converter						
1.4	Facilities						1765
	a. Floor Space						
	Region 1 1000 ft ²	30	1	30	30		
	Region 2-n 500 ft ² each	15	49	735	735		
	b. Backup Power (UPS)	20	50	1000	1000		
TOTALS							

COST DETAILS

OPTION 6

REMARKS: Fifty Switchers

II. RECURRING COSTS, K\$

Item	Description	Pre-1980			1980-1983			Item Subtotals
		Annual Cost (Each)	Number Required	Total Annual	Annual Cost (Each)	Number Required	Total Annual	
2.1	a. Communication Lines	-	-	491	--	-	537	491 537
	b. Space Link							
2.2	Hardware							439 462
	a. Basic Computer							
	Region	4.9	10	49	4.9	10	49	
	State	4.9	45	220.5	4.9	45	220.5	
	b. Line Interfaces	-	-	163	-	-	186	
	c. OPS Center	6	1	6	6	1		
	d. Microwave							
	e. Ground Station							
2.3	Facilities							422
	a. Floor Space							
	Region 1	4.8	1	4.8	4.8	1	4.8	
	Region 2-n	2.4	49	117.6	2.4	49	117.6	
	b. Backup Power	6	50	300	6	50	300	
III. OPERATIONS								
	a. Region 1							1083
	Supervisor	20	1	20	20	1	20	
	Programmers	17	2	34	17	2	34	
	Operators	12	8	96	12	8	96	
	Travel	2	1	2	2	1	2	
	b. Region 2-n							
Operators	17	49	833	17	49	833		
Travel	2	49	98	2	49	98		
TOTALS								

COST DETAILS

OPTION 7-a, 7-b

NUMBER OF REGIONS: Two

SWITCHER LOCATIONS: D.C. and Phoenix

REMARKS: Phase 7-a is a two-region terrestrial network
In Phase 7-b satellite ground stations are added at RSC locations.

I. ONE-TIME COSTS

Item	Description	Unit Cost, K\$	Number Required	Totals Cost, K\$	Installation Plan by Year of Installation		Item Subtotals	
					7a 1976	7b Jan 1977		
1.1	Communication Lines				15.7	0	16	0
1.2	Hardware	46	2	92	92		1017	1533
	a. Basic Computer	80.7	2	161.4	161.4			
	b. OPS Center	44.6	1	44.6	44.6			
	c. FDX Converter			0	0			
	d. Line Interfaces	-	-	718.6	718.6			
	e. Microwave			395	0	395		
	f. Ground Stations			1138	0	1138		
1.3	Computer Software	294	1	294	294		294	0
	a. RSCs			0	0			
	b. FDX Converter			0	0			
1.4	Facilities						85	0
	a. Floor Space							
	Region 1 1000 ft ²	30	1	30	30			
	Region 2-n 500 ft ² each	15	1	1	15			
b. Backup Power (UPS)	20	2	40	40				
TOTALS								

COST DETAILS

OPTION 7c, d

NUMBER OF REGIONS: Two

SWITCHER LOCATIONS: D.C. and Phoenix

REMARKS: One Region at D.C. in Phase 7-d

I. ONE-TIME COSTS

Item	Description	Unit Cost, K\$	Number Required	Total Cost, K\$	Installation Plan by Year of Installation		Item Subtotals	
					1976	1979		
1.1	Communication Lines			0	0	8.0	0	8.0
1.2	Hardware			0	0	0	5176	5044
	a. Basic Computer			0	0	0		
	b. OPS Center			0	0	0		
	c. FDX Converter	22	6	6	132	132		
	d. Line Interfaces	-	-	0	51	51		
	e. Microwave				1590	1590		
	f. Ground Stations				3403	3271		
1.3	Computer Software		0		0	0	40	0
	a. RSCs							
	b. FDX Converter	40	1	40	40	0		
1.4	Facilities						0	0
	a. Floor Space							
	Region 1 1000 ft ²	30	1	30	0			
	Region 2-n 500 ft ² ea	15			0			
b. Backup Power (UPS)	20			0				
TOTALS								

COST DETAILS
OPTION 7-a, 7-b

REMARKS: _____

II. RECURRING COSTS, K\$		7-a 0.5 yr			7-b 1.25 yr			
Item	Description	Jan 1977-June 1977			July 1977-Sept 1978			
		Annual Cost (Each)	Number Required	Total Annual	Annual Cost (Each)	Number Required	Total Annual	Item Subtotals
2.1	a. Communication Lines	-	-	461	-	-	425	461 811
	b. Space Link		0		-	-	386	
2.2	Hardware	4.9	2	9.8	4.9	2	9.8	109 329
	a. Basic Computer	9.9	2	19.8	9.9	2	19.8	
	b. Line Interfaces FDX Computer		0	73.3			71.2	
	c. OPS Center	6	1	6	6	1	6	
	d. Microwave		0		12	1	12.0	
	e. Ground Station		0		-	-	210.0	
2.3	Facilities							19 19
	a. Floor Space							
	Region 1	4.8	1	4.8	4.8	1	4.8	
	Region 2-n	2.4	1	2.4	2.4	1	2.4	
b. Backup Power	6	2	12.0	6	2	12.0		
III. OPERATIONS								
	a. Region 1							171 171
	Supervisor	20	1	20	20	1	20	
	Programmers	17	2	34	17	2	34	
	Operators	12	8	96	12	8	96	
	Travel	2	1	2	2	1	2	
	b. Region 2-n							
Operators	17	1	17	17	1	17		
Travel	2	1	2	2	1	2		
TOTALS								

COST DETAILS
OPTION 7-c, 7-d

REMARKS: _____

II. RECURRING COSTS, K\$		7-c 1 yr			7-d 4.25 yr			
Item	Description	Oct 1978-Sept 1979			Oct 1979-Dec 1983			
		Annual Cost (Each)	Number Required	Total Annual	Annual Cost (Each)	Number Required	Total Annual	Item Subtotals
2.1	a. Communication Lines	-	-	374	-	-	457	1110 1829
	b. Space Link Data Video	-	-	736	-	-	1372	1110 1829
2.2	Hardware	4.9	2	9.8	4.9	2	9.8	906 1522
	a. Basic Computer	9.9	2	19.8	9.9	2	19.8	
	Maintenance FDX	2	6	12	2	12	24	
	b. Line Interfaces FDX Computer			79.3			94.6	
	c. OPS Center	6	1	6	6	1	6	
	d. Microwave	12	5	60	12	9	108	
e. Ground Station			720			1260		
2.3	Facilities							19 11
	a. Floor Space							
	Region 1	4.8	1	4.8	4.8	1	4.8	
	Region 2-n	2.4	1	2.4	-	0	-	
b. Backup Power	6	2	12	6	1	6		
III. OPERATIONS								
	a. Region 1							171 152
	Supervisor	20	1	20	20	1	20	
	Programmers	17	2	34	17	2	34	
	Operators	12	8	96	12	8	96	
	Travel	2	1	2	2	1	2	
	b. Region 2-n							
Operators	17	1	17	-	0	-		
Travel	2	1	2	-	0	-		
TOTALS								

COST DETAILS
OPTION 8

NUMBER OF REGIONS: Ten

SWITCHER LOCATIONS: Ten Switchers

REMARKS: _____

I. ONE-TIME COSTS

Item	Description	Unit Cost, K\$	Number Required	Total Cost, K\$	Installation Plan by Year of Installation		Item Subtotals
					1976	1979	
1.1	Communication Lines	-	-	29.5	17.5	12.0	29.5
1.2	Hardware						1951.70
	a. Basic Computer	46	20	920	920		
	b. OPS Center	44.6	1	44.6	44.6		
	c. FDX Converter						
	d. Line Interfaces	-	-	987.1	987.1		
	e. Microwave						
	f. Ground Stations						
1.3	Computer Software	294	1	294	294		294
	a. RSCs						
	b. FDX Converter						
1.4	Facilities						365.0
	a. Floor Space						
	Region 1 1000 ft ²	30	1	30	30		
	Region 2-n 500 ft ² ea	15	9	135	135		
	b. Backup Power (UPS)	20	10	200	200		
TOTALS							2640.2

COST DETAILS
OPTION 8

REMARKS: Ten Switchers

II. RECURRING COSTS, K\$

Item	Description	Pre-1980			1980-1983			Item Subtotals
		Annual Cost (Each)	Number Required	Total Annual	Annual Cost (Each)	Number Required	Total Annual	
2.1	a. Communication Lines	-	-	428.6	-	-	496.1	428.6 496.1
	b. Space Link							
2.2	Hardware							225.1 242.9
	a. Basic Computer	4.9	20	98.0	4.9	20	98.0	
	b. Line Interfaces	-	-	121.1	-	-	138.9	
	c. OPS Center	6	1	6	6	1	6	
	d. Microwave							
	e. Ground Station							
2.3	Facilities							86.4
	a. Floor Space							
	Region 1	4.8	1	4.8	4.8	1	4.8	
	Region 2-n	2.4	9	21.6	2.4	9	21.6	
	b. Backup Power	6	10	60.0	6	10	60.0	
III. OPERATIONS								
	a. Region 1							323.0
	Supervisor	20	1	20	20	1	20	
	Programmers	17	2	34	17	2	34	
	Operators	12	8	96	12	8	96	
	Travel	2	1	2	2	1	2	
	b. Region 2-n							
	Operators	17	9	153	17	9	153	
	Travel	2	9	18	2	9	18	
TOTALS							323.0	

COST DETAILS

OPTION 9

NUMBER OF REGIONS: 25

SWITCHER LOCATIONS: 25 Switchers

REMARKS: Built from Five Regions

I. ONE-TIME COSTS

Item	Description	Unit Cost, K\$	Number Required	Total Cost, K\$	Installation Plan by Year of Installation		Item Subtotals
					1976	1979	
1.1	Communication Lines	-	-	33	20.1	12.9	33
1.2	Hardware	46	10	460			2345
	a. Basic Computer	46	20	920	1380		
	b. OPS Center	44.6	1	44.6	44.6		
	c. FDX Converter						
	d. Line Interfaces	-	-	920	920		
	e. Microwave						
	f. Ground Stations						
1.3	Computer Software	340	1	340			340
	a. RSCs						
	b. FDX Converter						
1.4	Facilities						890
	a. Floor Space						
	Region 1 1000 ft ²	30	1	30	30		
	Region 2-n 500 ft ² ea	15	24	360	360		
	b. Backup Power (UPS)	20	25	500	500		
TOTALS							

COST DETAILS

OPTION 9

REMARKS: 25 Switchers

II. RECURRING COSTS, K\$

Item	Description	Pre-1980			1980-1983			Item Subtotals	
		Annual Cost (Each)	Number Required	Total Annual	Annual Cost (Each)	Number Required	Total Annual		
2.1	a. Communication Lines	-	-	448.7	-	-	480.5	448.7	480.5
	b. Space Link								
2.2	Hardware							277	298
	a. Basic Computer								
	Regional Switchers	4.9	10	49	4.9	10	49		
	State Switchers	4.9	20	98	4.9	20	98		
	b. Line Interfaces	-	-	124	-	-	145		
	c. OPS Center	6	1	6	6	1	6		
	d. Microwave								
	e. Ground Station								
2.3	Facilities							212.4	
	a. Floor Space								
	Region 1	4.8	1	4.8	4.8	1	4.8		
	Region 2-n	2.4	24	57.6	2.4	24	57.6		
	b. Backup Power	6	25	150.0	6	25	150.0		
III. OPERATIONS									
	a. Region 1							608	
	Supervisor	20	1	20	20	1	20		
	Programmers	17	2	34	17	2	34		
	Operators	12	8	96	12	8	96		
	Travel	2	1	2	2	1	2		
	b. Region 2-n								
Operators	17	24	408	17	24	408			
Travel	2	24	48	2	24	48			
TOTALS									

APPENDIX J
EVALUATION CRITERIA BACKUP

I. AVERAGE RESPONSES

A select group of JPL and LEAA personnel was given evaluation forms on which ratings were to be entered for characteristics of five technical criteria. The five technical criteria considered were flexibility, ease of implementation, simplicity, privacy, and security. The procedure for filling out evaluation sheets and directions to respondents are discussed in Section IV of this report.

Table J-1 shows the average responses on a scale of 1 to 5 for each criterion characteristic from all respondents. The total average response for each criterion is also shown for each option, along with a scaled average on a scale from 0 to 100. On this scale a rating of 1 is equivalent to 0 and a rating of 5 is equivalent to 100.

Table J-1. Evaluation Form

	OPTION									
	1	2	3	4	5	6	7	8	9	
	N - DC S - PH	1 REG PH	1 REG DC	2 REG PH - DC	5 REG	50 REG	2 REG W/VIDEO	10 REG	25 REG	
I. Ease of Implementation										
a) Ease of switchover to new network from existing capability	4.25	3.25	3.25	3.50	2.50	1.75	3.00	2.00	1.75	
b) Minimum of technical design risks	4.25	3.75	3.75	4.00	3.00	1.50	3.50	2.25	1.50	
c) Number of switchers	4.00	3.75	3.75	3.75	2.50	1.25	3.25	2.25	1.50	
d) Number of lines	2.75	3.25	3.25	3.50	3.00	2.00	3.25	2.75	2.00	
Average	3.81	3.50	3.50	3.69	2.75	1.63	3.25	2.31	1.69	
Scaled Average	70	63	63	67	44	16	56	33	17	
II. Simplicity										
a) Is the design simple?	3.75	4.00	4.00	3.50	2.75	1.50	3.25	2.25	1.75	
b) Are control/operations simple?	3.50	4.00	4.00	3.50	2.75	1.25	3.25	2.00	1.25	
c) Maintenance	3.75	3.75	3.75	3.25	2.50	1.25	2.75	1.50	1.25	
d) Upgrades	3.75	4.00	3.00	3.00	2.75	2.50	3.00	2.50	2.75	
e) Routing simplicity	3.75	4.25	4.25	3.50	2.75	1.50	3.75	2.00	1.50	
f) Problems in user interface	3.25	3.50	3.50	3.00	3.00	2.75	3.00	2.75	2.75	
g) Simplicity of network checkout	3.75	4.00	4.00	3.25	2.75	1.00	3.25	2.25	1.25	
h) Simplicity of monitoring network (statistics gathering)	3.75	4.25	4.25	3.50	2.50	1.75	3.25	2.00	1.75	
Average	3.47	3.81	3.81	3.31	2.72	1.69	3.19	2.16	1.78	
Scaled Average	62	71	71	58	43	17	55	29	19	
III. Privacy										
a) Must data other than header (routing data message type) and message lengths be stored?	3.25	3.75	3.75	3.42	2.50	2.00	3.00	2.00	2.00	
b) Difficulty in accommodating new legislation changes	3.25	3.50	3.50	3.21	2.50	1.75	3.00	2.00	1.75	
Average	3.25	3.63	3.63	3.63	2.50	1.88	3.00	2.00	1.88	
Scaled Average	56	66	66	66	38	22	50	25	22	
IV. Flexibility										
a) Can new system terminations be easily added?	4.00	4.25	4.25	4.00	3.50	2.00	4.00	3.25	3.00	
b) Can network be expanded to handle traffic 2 x predictions?	2.75	2.75	2.75	3.00	3.00	3.25	3.00	3.50	3.50	
c) Expansion for 4 x predictions?	2.25	2.25	2.25	2.50	2.25	3.00	2.50	2.75	3.00	
d) Design flexibility during implementation phase	4.00	4.25	4.25	3.50	2.75	1.75	3.25	2.00	1.75	
e) Can audit or format checks be added easily?	3.25	3.75	3.75	3.25	2.50	1.50	3.50	1.75	1.50	
f) Can system termination connections to network be changed easily to balance switcher/line loading?	3.05	3.30	3.30	3.05	3.10	2.15	3.10	2.35	2.35	
Average	3.22	3.43	3.43	3.22	2.85	2.28	3.23	2.60	2.52	
Scaled Average	56	61	61	56	46	32	56	40	38	

Table J-1. (Contd)

	OPTION									
	1	2	3	4	5	6	7	8	9	
	N - DC S - PH	1 REG PH	1 REG DC	2 REG PH - DC	5 REG	50 REG	2 REG W/VIDEO	10 REG	25 REG	
V. Security										
a) Message intercept protection	3.33	3.67	3.67	3.33	2.33	2.00	3.33	2.00	2.00	
b) Message insertion protection	3.33	3.33	3.33	3.33	3.00	2.67	3.33	2.67	2.67	
c) Facility physical security against acts of violence	3.33	3.67	3.67	3.33	2.67	2.00	3.33	2.00	2.00	
d) Communication line physical security	3.33	3.33	3.33	3.00	2.67	2.67	3.00	2.67	2.67	
e) Dedication to criminal justice use	3.33	3.33	3.33	3.33	2.67	2.67	3.33	2.67	2.67	
f) Physical security against unwanted personnel having access to switchers	3.33	3.67	3.67	3.33	2.67	2.00	3.33	2.00	2.00	
g) Cost of security personnel if required	3.00	3.33	3.33	3.00	2.33	1.33	3.00	1.96	1.33	
h) Is present NGIC data base security maintainable?	2.67	2.67	2.67	2.67	2.67	2.33	2.67	2.67	2.67	
i) Can an act of physical violence severely degrade the network?	2.00	1.33	1.33	2.33	3.33	4.33	2.33	4.33	4.33	
Average	3.07	3.15	3.15	3.07	2.70	2.48	3.07	2.81	2.48	
Subtotal Scaled Average	52	54	54	52	44	37	52	45	37	

APPENDIX K

GLOSSARY OF TERMS AND ACRONYMS

- ACK. Positive acknowledgment by a receiving terminal to indicate that a block of data was received correctly.
- ACOUSTIC COUPLER. Form of modem that sends and receives data as tones over a telephone line using a conventional handset.
- ADDRESS. Coded representation of the destination of data, or of the originating terminal.
- ADMINISTRATIVE MESSAGE. Free-form message used for information transfer not necessarily file oriented.
- ALGORITHM. Prescribed set of well defined rules or processes for the solution of a problem in a finite number of steps.
- ALTERNATIVE ROUTING. Alternative communications path used if the normal one is not available.
- ANALOG TRANSMISSION. Transmission of a continuously variable signal as opposed to a discretely variable signal.
- ANSI (AMERICAN NATIONAL STANDARDS INSTITUTE). Organization sponsored by the Business Equipment Manufacturers Association (BEMA) for the purpose of establishing voluntary industry standards.
- ASCII (AMERICAN STANDARD CODE FOR INFORMATION INTERCHANGE). Eight-level code for data transfer adopted by the American Standards Association to achieve compatibility between data devices.
- ASYNCHRONOUS TRANSMISSION. Transmission in which each information character, or sometimes each word or small block, is individually synchronized, usually by the use of start and stop elements.
- ATTENDED OPERATION. Individuals are required at both stations to establish the connection and transfer data sets from talk (voice) mode to data mode.

AUDIT TRAIL. Sufficient data to permit identification and reconstruction of the route taken by a message from its origin to its destination.

AUTO ANSWER. Facility of an answering station to automatically respond to a call.

AUTO CALL. Facility of an originating station to automatically initiate a call.

AUTOMATIC MESSAGE SWITCHING CENTER. Center in which messages are automatically routed according to information contained within the message.

AUTOMATIC POLLING. Hardware feature of a telecommunications unit that processes a polling list, polling the terminals in order and handling negative responses to polling without interrupting the central processing unit.

AUXILIARY STORAGE. Storage that supplements another storage.

AVAILABILITY. Degree to which a system is ready when needed to process data.

BANDWIDTH. Measure of the ability of equipment or transmission links to pass a range of sinusoidal frequencies. Usually specified as some degradation of performance over some range of frequencies.

BASEBAND SIGNALING. Transmission of a signal at its original frequencies, i. e., a signal not changed by modulation.

BAUD. Unit of signaling speed. The speed in bauds is the number of discrete conditions, or signal events per second. (In this document, baud is the same as bits per second.)

BIT. Contraction of binary digit.

BIT RATE. Speed at which bits are transmitted, usually expressed in bits per second.

BIT SERIAL. Character transmitted on a single pair of wires in such a manner that each bit is presented successively.

BIT STREAM. Referring to a binary signal without regard to groupings by character.

BLOCK. Group of characters, bytes, or words communicated as a unit.

BLOCK CHECK CHARACTER (BCC). Character used for error detection sent at end of a message block. In the NALECOM Network, the BCC is the longitudinal redundancy check character (see LRC).

BPS. Bits per second.

BROADCAST. Transmission of a message intended for all receiving terminals connected to the communication channel.

BSC. IBM designation meaning binary synchronous communications, referring to a specific communications procedure using synchronous data transmission.

BUFFER. Temporary storage facility used to accumulate data into blocks of sufficient size to be handled efficiently by a processor or terminal.

BYTE. Set of binary digits (bits), usually eight.

CARRIER, COMMON. Organization regulated by the Federal Communications Commission or a public utilities commission, and required to supply communication service to all users at published rates.

CCH. Computerized criminal history.

CENTRAL OFFICE. Place where communications common carriers terminate customer lines and locate the switching equipment that interconnects those lines (also referred to as an exchange, end office, and local central office).

CHANNEL. Path for transmission between two or more points without common-carrier-provided terminal equipment. Also called circuit, line, link, path, or facility.

CHANNEL, DUPLEX. Channel providing simultaneous transmission in both directions (see FULL DUPLEX).

CHANNEL, HALF-DUPLEX. Channel providing transmission in either direction, but not simultaneously (see HALF DUPLEX).

CHARACTER. Letter, figure, number, punctuation, or other sign contained in a message. There may also be characters for special symbols and some control functions.

CIRCUIT. Means of both-way communication between two points, comprising associated "go" and "return" channels.

CIRCUIT, FOUR-WIRE. Communication path in which four wires (two for each direction of transmission) are presented to the station equipment.

CLOCK. Device for timing events. In data communications, a clock is required to control the timing of bits sent in a data stream, and to control the timing of the sampling of bits received in a data stream.

COMMUNICATION LINE. Any medium such as a wire or a telephone circuit that connects communication terminals.

COMMUNICATION LINK. Physical means of connecting two locations for the purpose of transmitting and receiving data.

COMMUNICATIONS PREPROCESSOR. Computer interposed between a general-purpose processor and communication channels to perform communication functions more efficiently than would be possible if the general-purpose processor performed both communications functions and general-purpose functions.

COMMUNICATIONS PROCESSOR. Computer dedicated to the performance of a complete communications function such as message switching.

COMPUTER. Data processor that can perform substantial computation, including numerous arithmetic or logic operations, without intervention by a human operator during the run.

CONDITIONING. Addition of equipment to a leased voice-grade channel to provide minimum values of line characteristics required for data transmission.

CONTENTION. Method of line control employed when two terminals request to use the same line at the same time. In the NALECOM Network, the RSC gains control of a line in the event that the regional switching centers and a system termination make simultaneous requests to transmit on the same line.

CONUS. Continental United States.

CONVERSATIONAL MODE. A procedure by which a terminal receiving low-priority data can temporarily gain control of the communication line to send its own high-priority data.

CONVERTER. Device capable of converting impulses from one mode to another, e.g., analog to digital, or parallel to serial, or one code to another.

CORE. Magnetic material capable of assuming and remaining in one of two conditions of magnetization, thus providing memory at a binary level.

CPM. Characters per minute.

CPS. Characters per second.

CPU. Central processing unit. Unit of a computer that includes the circuits controlling the interpretation and execution of instructions.

CRC. Method of error detection using cyclic redundancy check characters. A CRC character is generated at the transmitting terminal based on the contents of the message transmitted. A similar CRC generation is performed at the receiving terminal. If the two characters match, the message was probably received correctly.

DCS. Domestic communications satellite.

DATA FILE. Collection of related data records organized in a specific manner. For example, a payroll file (one record for each employee showing rate of pay, deductions, etc.), or an inventory file (one record for each inventory item showing cost, selling price, number in stock, etc.)

DATA LINK. Equipment that permits the transmission of information in electronic data format. Communication lines, modems, and communication controls of all stations connected to the line used in the transmission of information between two or more stations.

DATA SET. Synonym for MODEM commonly used by the Bell System.

DDD. Abbreviation for direct distance dialing, used for making long-distance telephone calls without the assistance of a telephone operator. DDD is frequently used to mean the switched telephone network.

DECODE. To apply a set of unambiguous rules specifying the way in which data can be restored to a previous representation, e.g., to reverse some previous encoding.

DECRYPTION. See DECODE.

DEMODULATION. Process of retrieving an original signal from a modulated carrier wave.

DIGITAL DATA. Information represented by a code consisting of a sequence of discrete elements.

DISTRIBUTED NETWORK. Network consisting of a large number of nodes usually capable of automatic alternate message path selection in the event of specific failures.

DOUBLE CONNECTED. An alternate routing concept in which a minimum of two routes is provided.

DUPLEX CHANNEL. Communication channel with the capability of simultaneous two-way communication (see FULL DUPLEX).

DUPLEXING. Use of duplicate computers, files, or circuitry, so that in the event of component failure an alternate can enable the system to carry on its work.

ENCODE. To apply a set of unambiguous rules specifying the way in which data may be represented such that a subsequent decoding is possible. Synonymous with CODE.

ENCRYPTION. Same as ENCODE with intent to keep data confidential.

ENQ. Enquiry character. Communication control character used to request a line.

EOT. End-of-transmission character. Communication control character used to indicate the conclusion of a transmission.

FACSIMILE (FAX). System for the transmission of images. The image is scanned at the transmitter, reconstructed at the receiving station, and duplicated on paper.

FAIL SOFTLY. When a piece of equipment fails softly, the programs let the system fall back to a degraded mode of operation rather than let it fail catastrophically and give no response to its users.

FBI. Federal Bureau of Investigation.

FCC. Federal Communications Commission.

FDM. Frequency-division multiplex. Multiplex system in which the available transmission frequency range is divided into narrower bands, each used for a separate channel.

FDX. Full-duplex transmission (see FULL DUPLEX).

FILE. Collection of related records treated as a unit.

FOUR-WIRE SYSTEM. System in which transmitting and receiving paths are carried on two separate two-wire circuits.

FULL DUPLEX. Communications mode in which messages can be transmitted in both directions simultaneously between two directly connected points.

GMIS. Grants Management Information Systems.

GRAPHIC. Symbol produced by a process such as handwriting, drawing, or printing.

GROUND STATION (see SATELLITE EARTH STATION).

HALF DUPLEX. Communications mode in which messages can be transmitted in only one direction at any given time between two directly connected points.

HANDSHAKING. Preliminary procedure performed by modems and/or terminals and computers to verify that communication has been established and can proceed.

HARDWARE. Physical equipment, as opposed to the computer program or method of use, e.g., mechanical, magnetic, electrical, or electronic devices. Contrast with SOFTWARE.

HIT. Successful comparison of data on file to an enquiry.

IBM. International Business Machines Corporation.

INTRA-REGION. Within the region defined.

INTERACTIVE. System that performs processing or problem-solving tasks by conducting a dialogue with the user.

INTER-REGION. Between regions defined.

INTERRUPT. Various external events such as the arrival of a new message or the completion of an input/output operation may interrupt the program that is presently in progress. An interrupt causes the central processing unit to leave the current program, store any working data that it needs to continue the program at a later time, and execute a different program which deals with the cause of the interrupt. After the cause of the interrupt has been dealt with, control returns to the original program that was interrupted.

JPL. Jet Propulsion Laboratory.

K. 1000 in decimal notation or nominally 1000 (actual 1024) when referring to storage capacity.

KILOBITS. 1000 bits.

KVA. Thousand volt-amperes. Expression of electrical power.

LEAA. Law Enforcement Assistance Administration.

LINE. Communication channel or telephone circuit.

LINE SWITCHING. Switching in which a circuit path is set up between the incoming and outgoing lines. Contrast with message switching (q. v.) in which no such physical path is established.

LINE TURN-AROUND. In half-duplex communication, the switching of transmission from one direction to transmission in the opposite direction.

LINK. Part of a communication circuit. A channel or circuit designed to be connected in tandem with other channels or circuits.

LOCAL LOOP. Line connecting a terminal to the central office equipment of a nearby telephone company.

LRC. Longitudinal redundancy check. Method of error detection using a parity bit for each level in the code being transmitted.

MASTER AND SLAVE COMPUTERS. Where two or more computers are working jointly, one of them is usually designated as a master computer and the others are slaves. When contention takes place, the master gains control of the communication line.

MDT. Mobile digital terminal.

MEMORY. Device for holding information.

MESSAGE SWITCHING. Technique of receiving a message, storing it until the proper outgoing line is available, and then retransmitting. No direct connection between the incoming and outgoing lines is set up as in line switching. Also called "store-and-forward switching."

MICROWAVE. Radio transmission using short wavelengths (1 mm to 1 m).

MODEM. MODulation/DEModulation device that provides the translation between the digital signals used by terminals and the analog signals transmitted over communication lines.

MTTF. MEAN TIME TO FAILURE. Average length of time for which a system, or a component of the system, works without fault.

MTTR. MEAN TIME TO REPAIR. The average time taken to correct a fault when a system, or a component of a system, develops a fault.

MULTIDROP. In a multidrop network, all stations are connected on a common transmission link. One station is designated as master and controls all network activity. Each station can listen to messages broadcast by the master, but only one station can transmit at a time under the master's control.

MULTIPLEX. To interleave or simultaneously transmit two or more messages on a single channel.

MUX. Abbreviation of multiplex.

N/A. Not applicable.

NALECOM. National Law Enforcement Communications. This is the title/acronym for the JPL study and is also used to refer to the NALECOM Network.

NCIC. National Crime Information Center. Law enforcement data base and communications network operated by the FBI and used to provide data of interstate/national interest. Communications are from states to the NCIC and vice versa.

NCJRS. National Criminal Justice Reference Service.

NCJSDB. National Criminal Justice Statistics Data Base.

NETWORK. Interconnection of multiple communication channels and multiple terminals and/or computers.

NLETS. National Law Enforcement Telecommunications System.

Communications network that provides message routing from state to state for a variety of message types and state to national or national to state for administrative messages only.

NRZ. Non-return-to-zero recording.

NSEC. Nanoseconds (10^{-9} seconds).

O-D. Origin-destination.

OVERFLOW. That part of the result of an operation that exceeds the capacity of the intended unit of storage.

OVERLOAD. Rate of input to some real-time systems varies from one moment to another. At times a momentary overload may occur because all communication lines transmit data to the computer at once, and the computer is not sufficiently fast to process this sudden flood of messages. There are various types of emergency action possible for dealing with this type of overload.

PARITY. Method of error detection using an extra bit to make the total number of bits in a character or group of characters either odd or even. For example if a character is sent with odd parity, it should be received with odd parity if no errors are introduced by the communication process.

POINT TO POINT. Communication between two terminal points only, as opposed to MULTIDROP.

POINT-TO-POINT NETWORK. Network in which a central station is individually connected to each of the tributary stations and can converse with any station without interference from the others (See STAR NETWORK).

POLLING. Regular and systematic interrogation of terminals to determine if a terminal has messages awaiting transmission, and to determine the state of readiness of a terminal to accept messages.

PRIVATE LINE. Communication channel for private use; a leased, owned, or otherwise dedicated channel.

PROCESSOR. Device capable of systematic sequence of operations performed upon data.

PROPAGATION DELAY. Time necessary for a signal to travel from one point on a circuit to another.

QUEUE. Group of items in a system waiting for the attention of the processor.

REAL TIME SYSTEM. A system that appears to perform computational functions at a speed sufficient to honor data inputs and completely process them before new data inputs occur.

REDUNDANCY. Use of backup hardware to take over for the primary unit in the case of failure.

REPEATER. Device, installed at regularly spaced intervals in a transmission facility, which restores signals that have been distorted because of attenuation to their original shape and transmission level.

RSC. Regional switching centers. Message switching computer centers that are the major internal nodes of the NALECOM Network.

RVI. Reverse interrupt. A method by which a terminal receiving data can notify the sending terminal that it also has data to send.

SECURITY. Prevention of access to or use of data or programs without authorization.

SES. Satellite Earth station. Also called satellite ground station, which contains equipment required to communicate through a satellite in space.

SIMPLEX. Communications system or equipment capable of transmission in one direction only.

SLAVE OPERATION. See MASTER AND SLAVE COMPUTERS.

SOFTWARE. Term commonly used to describe the set of programs for a computer including compilers, assemblers, executive routines, and input and output libraries. Contrast with HARDWARE.

STAR NETWORK. Point-to-point network with one point common to all others.

STORE-AND-FORWARD MESSAGE SWITCHING. Facility for accepting messages as rapidly as they are received from originating terminals, storing the messages, and sending the messages to destination terminals when communication channels are available.

SUPERVISOR. Part of the control program that coordinates the use of resources and maintains the flow of CPU operations.

SYNCHRONOUS. Events occurring at the same time. In synchronous data communication, the bit sampling rate at the receiving station must be precisely the same as the bit transmission rate at the transmitting station, and the point at which one character ends and the next character begins must be recognized by the receiving station by means of a sync character.

SYNCHRONOUS TRANSMISSION. A mode of data transmission where clocked synchronization characters are periodically transmitted to maintain the timing of events between the transmitting and receiving sites.

SYSTEM TERMINATION. Point at which the NALECOM Network interfaces with the user's law enforcement network, specifically at the network user's side of the modem connecting the user to the network.

SWITCHING CENTER. Location which terminates multiple circuits and is capable of interconnecting circuits or transferring traffic between circuits. Can be automatic, semi-automatic, or torn-tape. A location where incoming data from one circuit is transferred to the appropriate outgoing circuit.

SWITCHOVER. When a failure occurs in the equipment, a switch may occur to an alternative component. This can be, for example, an alternative file unit, an alternative communication line, or an alternative computer. The switchover process may be automatic under program control or it may be manual.

TARIFF. Published schedule of regulated charges for common carrier services and equipment.

TERMINAL. End point in a communication link, with the term frequently applied to both computer and to operator-oriented equipment comprising keyboard, printer, card reader, punches, etc.

TERRESTRIAL LINES. Transmission facilities on or near the earth's surface. Can actually be wire lines, cable, or microwave channels.

TIME DIVISION MULTIPLEXING. Merging of several bit streams of lower bit rates into a composite signal for transmission over a communication channel of higher bit-rate capacity.

TIME SHARING. Pertaining to the interleaved use of the time of a device.

TOPOLOGY. A description of the placement of network components and their interconnectivity.

TRANSPARENT TEXT MODE. Optional mode of transmission (within the IBM BSC protocol) which allows transmission of any characters, including characters that would normally be interpreted as control characters if the transparent text mode had not been initiated.

TWO-WIRE SYSTEM. System in which all communication transmitted or received is carried over a two-wire circuit or equivalent.

UPS. Uninterruptible power supply.

USASCII. Same as ASCII.

VRC. Vertical redundancy check. Scheme for redundancy checking where a parity bit is generated and affixed to each character transmitted. It is called vertical because a punched tape representation of data is generally visualized as having characters running vertically when the tape runs horizontally.

VIDEO. Synonymous with television.

VOICE-GRADE CHANNEL. Channel suitable for transmission of speech, digital or analog data, or facsimile, generally with a frequency range of about 300 to 3000 Hz. Data can be transmitted on this channel at up to 9600 bps.

WATS (WIDE AREA TELEPHONE SERVICE). Service provided by telephone companies in the United States which permits a customer by use of an access line to make calls to telephones in a specific zone on a dial basis, for a monthly charge.

WIDEBAND CHANNEL. Channel wider in bandwidth than a voice-grade channel.

REFERENCES

1. Phase II Work Plan: Extended Requirements Analysis and Design of a National Law Enforcement Telecommunications System, JPL Document 1200-189, Sept. 1974.*
2. National Criminal Justice Telecommunications Requirements, JPL Document 1200-133, Rev. A., June 1974.*
3. National Law Enforcement Telecommunications Network Functional Requirements, JPL Document 1200-178, June 1974.*
4. National Law Enforcement Communication Network (NALECOM) USER Guidelines, JPL Document 1200-168, June 1974.*
5. U.S.A. Standard Code for Information Exchange (USASCII), U.S.A. Standard X3.4.
6. Proposed American National Standard for Advanced Data Communications Control Procedures (ADCCP), ANSI Standard X3534/475, Dec. 1973.
7. National Advisory Commission on Criminal Justice Standards and Goals, Criminal Justice System, Washington, D.C., 1973.
8. Implementation Plan For A National Criminal Justice Telecommunication System, JPL Document 1200-174, June 1974.*

*JPL Internal Document.

END

7 tables/memo