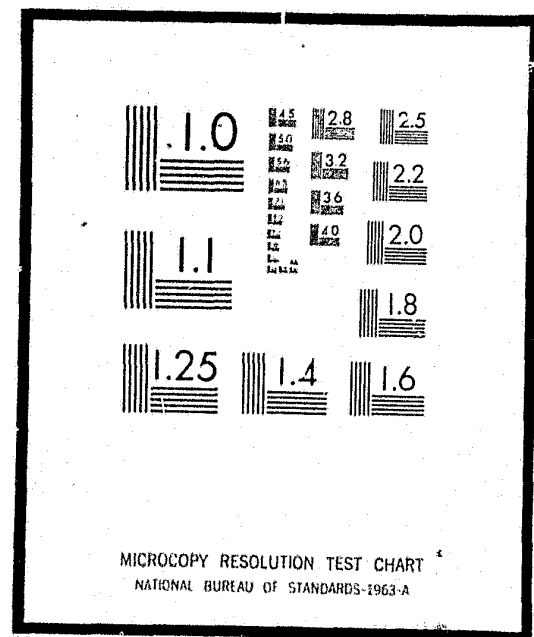


NCJRS

This microfiche was produced from documents received for inclusion in the NCJRS data base. Since NCJRS cannot exercise control over the physical condition of the documents submitted, the individual frame quality will vary. The resolution chart on this frame may be used to evaluate the document quality.



Microfilming procedures used to create this fiche comply with the standards set forth in 41CFR 101-11.504

Points of view or opinions stated in this document are those of the author(s) and do not represent the official position or policies of the U.S. Department of Justice.

U.S. DEPARTMENT OF JUSTICE
LAW ENFORCEMENT ASSISTANCE ADMINISTRATION
NATIONAL CRIMINAL JUSTICE REFERENCE SERVICE
WASHINGTON, D.C. 20531

Date filmed

4/30/76

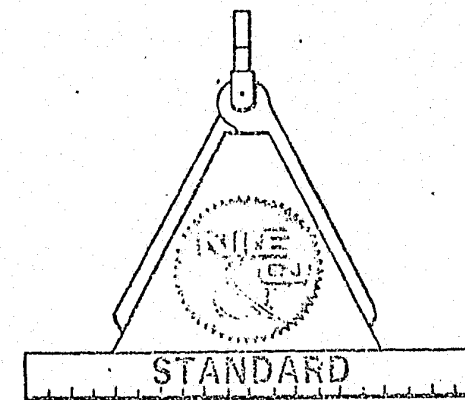
29643

NILECJ-STD-0206.00

JUNE 1975

LAW ENFORCEMENT STANDARDS PROGRAM

FIXED AND BASE STATION FM RECEIVERS



U.S. DEPARTMENT OF JUSTICE
Law Enforcement Assistance Administration
National Institute of Law Enforcement and Criminal Justice

LAW ENFORCEMENT STANDARDS PROGRAM

NILECJ STANDARD FOR

FIXED AND BASE STATION FM RECEIVERS

A Voluntary National Standard Promulgated by the
National Institute of Law Enforcement and Criminal Justice

JUNE 1975

U.S. DEPARTMENT OF JUSTICE

Law Enforcement Assistance Administration

National Institute of Law Enforcement and Criminal Justice

LAW ENFORCEMENT ASSISTANCE ADMINISTRATION

Richard W. Velde, Administrator
Charles R. Work, Deputy Administrator

NATIONAL INSTITUTE OF LAW ENFORCEMENT
AND CRIMINAL JUSTICE
Gerald M. Caplan, Director

ACKNOWLEDGMENTS

This standard was formulated by the Law Enforcement Standards Laboratory of the National Bureau of Standards under the direction of Marshall J. Treado, Program Manager for Communications Systems, and Jacob J. Diamond, Chief of LESL. NBS Electromagnetics Division staff members responsible for the preparation of the standard were Harold E. Taggart, project manager, M. Gerald Arthur, Leon F. Saulsbery, Winston W. Scott, Jr., and John F. Shafer. Acknowledgment is given to previous work in this field by the Associated Public-Safety Communications Officers, Inc.; the Institute of Electrical and Electronics Engineers, Inc.; the Electronic Industries Association; the American National Standards Institute; and the International Electrotechnical Commission.

NILECJ STANDARD
for
Fixed and Base Station FM Receivers
Contents

	Page
Foreword	v
1. Purpose and Scope	1
2. Classification	1
3. Definitions	1
4. Requirements	1
4.1 Minimum Performance	1
4.2 User Information	1
4.3 Test Sequence	1
4.4 Environmental Characteristics	1
4.5 SINAD Sensitivity	1
4.6 Selectivity Characteristics	1
4.7 Squelch Characteristics	1
4.8 Audiofrequency Characteristics	1
5. Test Methods	1
5.1 Standard Test Conditions	1
5.2 Test Equipment	1
5.3 Environmental Tests	1
5.4 SINAD Sensitivity Test	1
5.5 Selectivity Tests	1
5.6 Squelch Tests	1
5.7 Audiofrequency Tests	1
Appendix A--Bibliography	1

FOREWORD

Following a Congressional mandate* to develop new and improved techniques, systems, and equipment to strengthen law enforcement and criminal justice, the National Institute of Law Enforcement and Criminal Justice (NILECJ) has established the Law Enforcement Standards Laboratory (LESL) at the National Bureau of Standards. LESL's function is to conduct research that will assist law enforcement and criminal justice agencies in the selection and procurement of quality equipment.

In response to priorities established by NILECJ, LESL is (1) subjecting existing equipment to laboratory testing and evaluation and (2) conducting research leading to the development of several series of documents, including national voluntary equipment standards, user guidelines, state-of-the-art surveys and other reports.

This document, NILECJ-STD-0206.00, Fixed and Base Station FM Receivers, is a law enforcement equipment standard developed by LESL and approved and issued by NILECJ. Additional standards as well as other documents are being issued under the LESL program in the areas of protective equipment, communications equipment, security systems, weapons, emergency equipment, investigative aids, vehicles and clothing.

This equipment standard is a technical document consisting of performance and other requirements together with a description of test methods. Equipment which can meet these requirements is of superior quality and is suited to the needs of law enforcement agencies. Purchasing agents can use the test methods described in this standard to determine firsthand whether a particular equipment item meets the requirements of the standard, or they may have the tests conducted on their behalf by a qualified testing laboratory. Law enforcement personnel may also reference this standard in purchase documents and require that any equipment offered for purchase meet its requirements and that this compliance be either guaranteed by the vendor or attested to by an independent testing laboratory.

The necessarily technical nature of this NILECJ standard, and its special focus as a procurement aid, make it of limited use to those who seek general guidance concerning fixed and base station FM receivers. The NILECJ Guideline Series is designed to fill that need. We plan to issue guidelines to this as well as other law enforcement equipment as soon as possible, within the constraints of available funding and the overall NILECJ program.

*Section 402(b) of the Omnibus Crime Control and Safe Streets Act of 1968, as amended.

The guideline documents to be issued are highly readable and tutorial in nature in contrast to the standards, which are highly technical, and intended for laboratory use by technical personnel. The guidelines will provide, in non-technical language, information for purchasing agents and other interested persons concerning the capabilities of equipment currently available. They may then select equipment appropriate to the performance required by their agency. Recommendations for the development of particular guidelines should be sent to us.

NILECJ standards are subjected to continuing review. Technical comments and recommended revisions are invited from all interested parties. Suggestions should be addressed to the Program Manager for Standards, National Institute of Law Enforcement and Criminal Justice, Law Enforcement Assistance Administration, U.S. Department of Justice, Washington, D.C. 20531.

Lester D. Shubin
Program Manager for Standards
National Institute of Law
Enforcement and Criminal Justice

NILECJ STANDARD
for
FIXED AND BASE STATION FM RECEIVERS

1. PURPOSE AND SCOPE

The purpose of this document is to establish performance requirements and methods of test for frequency modulated fixed and base station receivers used by law enforcement agencies. This standard applies to voice-modulated, non-multiplex receivers which either do not have special subsystems such as selective signaling or voice privacy, or in which such subsystems are disabled or by-passed during testing for compliance with this standard.

2. CLASSIFICATION

For the purposes of this standard, fixed and base station FM receivers are classified by their operating frequencies and their channel spacing.

2.1 Type I

Receivers which operate in the 400-512 MHz band with a channel spacing of 25 kHz.

2.2 Type II

Receivers which operate in the 150-174 MHz band with a channel spacing of 30 kHz.

2.3 Type III

Receivers which operate in the 25-50 MHz band with a channel spacing of 20 kHz.

3. DEFINITIONS

The principal terms used in this document are defined in this section. Additional definitions relating to law enforcement communications are given in LESP-RPT-0203.00, "Technical Terms and Definitions Used With Law Enforcement Communications Equipment (Radio Antennas, Transmitters and Receivers)."

3.1 Adjacent-Channel Selectivity and Desensitization

The ability of a receiver to discriminate between a desired signal and an undesired signal at the frequency of an adjacent channel.

3.2 Audio Hum and Noise Power

The average audiofrequency power dissipated in a load across the output terminals of a receiver having an unmodulated radio-frequency signal input.

3.3 Audio Noise Output Power

The average audiofrequency power dissipated in a load across the output terminals of an unmodulated receiver having no radio-frequency signal input.

3.4 Audio Output Power

The audiofrequency power dissipated in a load across the output terminals of an unmodulated receiver having a modulated radio-frequency signal input.

3.5 Audiofrequency Harmonic Distortion

The generation, in a system, of integral multiples of a single audiofrequency input signal.

3.6 Audiofrequency Response

The variation in the output of a receiver as a function of frequency within a specified bandwidth.

3.7 Intermodulation Attenuation

The ratio, expressed in decibels, of (1) selected rf signal levels that produce an intermodulation response to (2) the receiver's SINAD sensitivity.

3.8 Intermodulation Response

The response resulting from the mixing of two or more frequencies, in the nonlinear elements of a receiver, in which a resultant frequency is generated that falls within the range of frequencies passed by the receiver.

3.9 Modulation Acceptance Bandwidth

The maximum frequency deviation of an input signal which has twice the amplitude of the 12 dB sensitivity voltage and which produces a 12 dB SINAD ratio.

3.10 Noise Quieting

The reduction of audio noise output power caused by an rf signal.

3.11 Rated System Deviation

The maximum carrier frequency deviation permitted by the FCC; for law enforcement communications systems, it is ± 5 kHz.

3.12 Receive Mode

The condition of a receiver when unmodulated and receiving information.

3.13 Selectivity

The extent to which a receiver is capable of differentiating between the desired signal and disturbances at other frequencies.

3.14 SINAD Ratio

A ratio of the audio output of a receiver, expressed in decibels, equal to (1) signal plus noise plus distortion to (2) noise plus distortion; from Signal Noise And Distortion Ratio.

3.15 SINAD Sensitivity

The minimum modulated rf signal input level required to produce a specified SINAD ratio at a designated audio output power level.

3.16 Spurious Response

The output of a receiver caused by a signal at a frequency other than that to which the receiver is tuned.

3.17 Squelch Attack Time

The time required to produce a designated audio output power level upon application of an rf input signal.

3.18 Squelch Block.

A squelched condition resulting from excessive frequency deviation.

3.19 Squelch

A circuit function for preventing a radio receiver from producing audio output power in the absence of rf signals.

3.20 Squelch Release Time

The time required to reduce audio noise output power to a designated level upon removal of the rf input signal.

3.21 Threshold Squelch Sensitivity

The minimum rf signal input level with standard modulation required to unsquelch the receiver when the squelch control is in the threshold squelched position.

3.22 Threshold Squelched Position

The adjustment of the squelch control, starting from the maximum unsquelched position, that first reduces the audio noise output power by a specified amount.

3.23 Tight-Squelch Sensitivity

The minimum standard modulated rf signal input level required to unsquelch the receiver when the squelch control is in the maximum squelched position.

4. REQUIREMENTS

4.1 Minimum Performance

The requirement for each receiver characteristic shall be the value listed in table 1. These performance requirements meet or exceed those given in the Rules and Regulations published by the Federal Communications Commission. In addition to the requirements listed, all of the licensing and operating requirements of the FCC Rules and Regulations shall apply.

4.

4.2 User Information

The receiver operating frequencies and nominal values for the receiver audio output impedance, the power supply voltage and each receiver characteristic listed in table 1 shall be included in the information supplied to the user by the manufacturer or distributor.

4.3 Test Sequence

The test sequence shall be in the order listed herein. Each receiver shall be subjected to the environmental tests, and then shall be tested for conformance with paragraphs 4.5 through 4.8.

4.4 Environmental Characteristics

The ability of the receiver to operate in environmental extremes shall be determined using the test methods described in paragraph 5.3.

4.4.1 Temperature Stability

When the receiver is operated at temperatures of -30°C (-22°F) and 60°C (140°F), its performance shall not be degraded, with respect to the appropriate value in table 1, more than (item V through AB), for the characteristics listed. In addition, the audio distortion shall be less than (item AC) for an rf signal with standard modulation.

4.4.2 Humidity Stability

After the receiver has been maintained at 50°C (122°F) and 90 percent relative humidity or greater for at least eight hours, its performance shall not be degraded, with respect to the appropriate value in table 1, more than (item AD through AJ) for the characteristics listed. In addition, the audio distortion shall be less than (item AK) for an rf signal with standard modulation.

4.5 SINAD Sensitivity

When measured in accordance with paragraph 5.4, the SINAD sensitivity of the receiver shall be (item A) or less with a SINAD ratio of 12 dB and at least 50 percent of the value of audio output power (item M). When the standard power supply voltage (5.1.3) is varied ± 10 percent, the SINAD sensitivity shall be (item B) or less.

5.

4.6 Selectivity Characteristics

The selectivity characteristics of modulation acceptance bandwidth, adjacent channel selectivity and desensitization, spurious response attenuation and intermodulation attenuation shall be measured in accordance with paragraph 5.5.

4.6.1 Modulation Acceptance Bandwidth

The modulation acceptance bandwidth of the receiver shall be no less than (item C) for an applied rf signal 6 dB above the measured 12 dB SINAD sensitivity value.

4.6.2 Adjacent Channel Selectivity and Desensitization

The adjacent channel selectivity and desensitization of the receiver shall be (item D) or more for a degradation of an on-channel signal from 12 dB SINAD ratio to 6 dB SINAD ratio caused by an adjacent channel signal.

4.6.3 Spurious Response Attenuation

The spurious response attenuation of the receiver shall be (item E) or more as compared to the on-channel 20 dB noise quieting signal voltage for responses of the receiver between the lowest intermediate frequency of the receiver and 1000 MHz.

4.6.4 Intermodulation Attenuation

The intermodulation attenuation of the receiver shall be (item F) or more for a degradation of an on-channel signal from 12 dB SINAD ratio to 6 dB SINAD ratio by two relatively strong signals located at one- and two-channel spacings, respectively, from the receiver frequency, both signals being at frequencies either above or below the on-channel signal.

4.7 Squelch Characteristics

The squelch characteristics of sensitivity, block, attack time and release time shall be measured in accordance with paragraph 5.6.

4.7.1 Squelch Sensitivity

The threshold squelch sensitivity of the receiver shall be (item G) or less. The tight squelch sensitivity shall be (item H) or less. When the standard power supply voltage is varied ± 10 percent, the threshold squelch sensitivity shall be (item I) or less.

4.7.2 Squelch Block

The receiver shall not squelch for modulation frequencies from 0.3 to 3.0 kHz when the squelch control is adjusted to the maximum squelch position and the frequency deviation of the input signal is (item J) or less.

4.7.3 Squelch Attack Time

The squelch attack time for the receiver to produce 90 percent of the audio output power (item M) shall be (item K) or less.

4.7.4 Squelch Release Time

The squelch release time for the audio output of the receiver to decrease to 10 percent of the audio output power (item M) shall be (item L) or less.

4.8 Audiofrequency Characteristics

The audiofrequency characteristics of output power, distortion, frequency response, and hum and noise shall be measured in accordance with paragraph 5.7.

4.8.1 Audio Output Power

The audio output power of the receiver shall be at least (item M) if a loudspeaker is used at the receiver output, (item N) if earphones are used and (item O) if a telephone line is used. When the standard power supply voltage is varied ± 10 percent, the audio output power shall not be reduced more than (item P) below (item M).

4.8.2 Audio Distortion

Audio distortions at audio output powers of (item M, N and O) shall be less than (item Q) for an rf signal with standard modulation.

4.8.3 Audiofrequency Response

The audiofrequency response of the receiver, when used with a loudspeaker, shall be within (item R) of an ideal 6 dB per octave de-emphasis curve with constant frequency deviation at all frequencies between 0.3 and 3.0 kHz. When used with earphones or telephone lines, the audiofrequency response of the receiver shall be within (item S) of the same curve at all frequencies between 0.3 and 3.0 kHz.

4.B.4 Audio Hum and Noise

The audio hum and noise output power from the receiver in an unquieted condition shall be (item T) or more, and in a quieted condition shall be (item U) or more below audio output power (item H).

5. TEST METHODS

5.1 Standard Test Conditions

Allow all measurement equipment to warm up until the system has achieved sufficient stability to perform the measurement. Unless otherwise specified, perform all measurements under standard test conditions. Disable or bypass all special subsystems before testing.

5.1.1 Standard Temperature

Standard ambient temperature shall be between 20°C (68°F) and 30°C (86°F).

5.1.2 Standard Relative Humidity

Standard ambient relative humidity shall be between 10 and 85 percent.

5.1.3 Standard Power Supply Voltage

The standard supply voltage shall be 120 volts, 60 hertz, unless otherwise stated by the manufacturer. Variable auto transformers or tapped transformers may be used to adjust the supply voltage to the required value, which should be measured at the receiver power supply input terminals, if practicable, and adjusted to within one percent of the nominal value.

5.1.4 Standard Test Frequency

The standard receiver test frequency shall be any one of the operating frequencies as specified in paragraph 4.2.

5.1.5 Standard Test Modulation

Standard test modulation shall be a 1 kHz sinusoidal modulating signal having less than one percent total distortion at the level required to produce a ± 3 kHz frequency deviation.

5.1.6 Standard Squelch Adjustment

The squelch control shall be adjusted to the maximum unquieted position for all measurements except where otherwise specified.

5.1.7 Standard Duty Cycle

The standard duty cycle shall be continuous operation in the receive mode.

5.2 Test Equipment

This section is limited to that equipment which is the most critical in making the measurements discussed in this standard. All other test equipment shall be of comparable quality.

5.2.1 FM Signal Generator

The FM signal generator shall have a 50 ohm output impedance, a maximum standing-wave ratio of 1.2, and an output level accurate to ± 2 dB, when terminated in a 50 ohm load. The generator should include a digital frequency counter having an uncertainty no greater than one part in 10^6 , and a deviation monitor or calibrated control for determining the peak frequency deviation with an uncertainty no greater than five percent. If an integral frequency counter is not included, a separate frequency counter having the required accuracy shall be provided.

5.2.2 CW Signal Generator

The CW signal generator shall have the same characteristics as described in paragraph 5.2.1 except that the FM capability is not required.

5.2.3 Standard RF Input Load

The standard rf input load shall consist of a shielded 50 ohm resistor whose standing wave ratio is less than 1.05.

5.2.4 Standard Audio Output Load

The standard audio output load shall be a resistor having a resistance equal to the output impedance of the receiver and a power rating equal to or exceeding the nominal audio output power of the receiver. A filter network shall not be used between the audio output terminals and the audio output load. If an external monitor speaker is used, a matching network to maintain the standard output load impedance at the audio output terminals shall be provided.

5.2.5 Audiofrequency Voltmeter

The audiofrequency voltmeter shall measure rms voltage rather than average or peak voltage. Its measurement uncertainty shall be one percent or less.

5.2.6 Signal Combiner

A signal combiner shall be used when two or more signal generators are connected to the receiver under test. Its amplitude imbalance shall be no greater than 0.2 dB, its standing wave ratio shall be no greater than 1.3 and the isolation between input terminals shall be a minimum of 30 dB. A variety of multiport devices may be used as signal combiners including power dividers, directional couplers, and hybrid junctions.

5.2.7 Environmental Chamber

The environmental chamber shall produce air temperatures from -30 to 60°C (-22 to 140°F) and relative humidities in excess of 90 percent while shielding the test receiver from heating or cooling air currents blowing directly on it. The temperature of the test receiver shall be measured with a thermometer separate from the sensor used to control the chamber air temperature. Likewise, humidity shall be measured with a hygrometer separate from the sensor used to control humidity.

5.3 Environmental Tests

5.3.1 Temperature Test

Place the receiver, with outer cases installed and with power turned off, in the environmental chamber. Adjust the temperature to $-30 \pm 2^{\circ}\text{C}$ ($-22 \pm 3.6^{\circ}\text{F}$). Allow the receiver to reach temperature equilibrium and maintain it at this temperature for 30 minutes. Turn on the receiver power. Fifteen minutes after turn-on, test the receiver to determine whether it meets the requirements of paragraph 4.4.1. Repeat the above procedure at a temperature of $60 \pm 2^{\circ}\text{C}$ ($140 \pm 3.6^{\circ}\text{F}$).

5.3.2 Humidity Test

Place the receiver, with power turned off, in the environmental chamber. Adjust the relative humidity to a minimum of 90 percent at 50°C (122°F) or more. Maintain the receiver at these conditions for at least 8 hours. With the receiver still in this environment, turn on the receiver power, allow the receiver to operate for 15 minutes, and then test it to determine whether it meets the requirements of paragraph 4.4.2.

5.4 SINAD Sensitivity Test

Interconnect the receiver and test equipment as shown in figure 1. Modulate the FM signal generator with standard test modulation and adjust the generator to the standard test frequency. Adjust the generator for one millivolt output and the receiver volume control for audio output power (item M). Do not readjust the volume control for the remainder of the measurement. Decrease the output level of the generator until the SINAD ratio of the receiver is 12 dB, as determined with the distortion analyzer. Measure the audio output power to make certain it is at least 50 percent of item M and record the generator output voltage. Repeat the above using plus 10 percent and minus 10 percent changes in standard power supply voltage.

5.5 Selectivity Tests

5.5.1 Modulation Acceptance Bandwidth Test

Interconnect the receiver and test equipment as shown in figure 1. Adjust the receiver and FM signal generator in accordance with paragraph 5.4 for the 12 dB SINAD signal sensitivity. Increase the output of the generator by 6 dB, and increase the frequency deviation of the generator until the SINAD ratio is again 12 dB. Record the frequency deviation.

5.5.2 Adjacent Channel Selectivity and Desensitization Test

Interconnect the receiver and test equipment as shown in figure 2. With the output of generator #2 set to zero, adjust the receiver and signal generator #1 in accordance with paragraph 5.4 for the 12 dB SINAD signal sensitivity. Adjust signal generator #2 for 3 kHz frequency deviation at 400 Hz, and set it to a frequency corresponding to the center of the next higher adjacent channel. Then adjust the output of signal generator #2 to produce a 6 dB SINAD ratio with both signals present. The ratio, expressed in decibels, of the output voltage of signal generator #2 to that of signal generator #1 is the adjacent channel selectivity for the upper channel. Repeat the above procedure for the next lower adjacent channel. The smaller of the two ratios is the required measurement.

5.5.3 Spurious Response Attenuation Test

Interconnect the receiver and test equipment as shown in figure 3. Adjust the unmodulated (CW) signal generator to the standard test frequency. With the generator adjusted for zero output, adjust the receiver volume control to produce 25 percent of item H. This output power is entirely noise power. Do not readjust the volume control for the remainder of the measurement. Increase the output of the generator until the audio noise output power of the receiver is decreased by 20 dB, i.e., 20 dB of noise quieting. Note the generator output in decibels at this frequency. Then increase the output of the generator to approximately 0.1 volt, and slowly vary the generator frequency continuously from just below the lowest intermediate frequency of the receiver to 1000 MHz. Note each frequency that produces a receiver response as indicated by noise quieting in the receiver's audio output. Ignore harmonic frequencies of the generator that fall within the channel to which the receiver is tuned. For each response, adjust the generator output to produce 20 dB of noise quieting. Record the generator output in decibels. The generator output at the spurious response frequency minus the generator output at the standard test frequency is the spurious response attenuation. Repeat for all spurious responses. The smallest attenuation is the value sought.

5.5.4 Intermodulation Attenuation Test

Interconnect the receiver and test equipment as shown in figure 4. With the output levels of signal generators #2 and #3 set to zero, adjust the receiver and FM signal generator #1 in accordance with paragraph 5.4 until a 12 dB SINAD ratio is reached. Adjust the unmodulated generator #2 to the center frequency of the next higher adjacent channel. Adjust generator #3 for 3 kHz frequency deviation at 400 Hz, and set it to the center frequency of the second higher adjacent channel, i.e., two channels above the standard test frequency. Then adjust the output levels of generators #2 and #3 to produce a 6 dB SINAD ratio with all three signals present. Maintain generators #2 and #3 at equal output voltages throughout the measurement. Adjust slightly the frequency of generator #3 to obtain the 6 dB SINAD ratio with the minimum signal levels from generators #2 and #3. The ratio, expressed in decibels, of the output voltage of generator #2 (or #3) to that of generator #1 is the intermodulation attenuation for the upper channels. Repeat the above procedure for the lower two adjacent channels, with generator #3 set to the lowest channel. The smaller of the two ratios is the value sought.

5.6 Squelch Tests

5.6.1 Squelch Sensitivity Tests

Interconnect the receiver and test equipment as shown in figure 1. Adjust the receiver and FM signal generator in accordance with paragraph 5.4 for the 12 dB SINAD signal sensitivity. Set the output level of the generator to zero, and measure the audio noise output power. Slowly adjust the squelch control until the audio noise output power drops abruptly (40 dB or more). Do not adjust the squelch control any further. This is the threshold squelch position. Increase the output level of the signal generator until the measured audio output power is within 10 dB of the audio output power (item M). The signal generator output voltage is the value for threshold squelch sensitivity. Repeat using plus 10 percent and minus 10 percent standard power supply voltage.

Repeat the above procedure with the squelch control in the maximum squelched position. The resultant signal generator output voltage is the value for tight squelch sensitivity.

5.6.2 Squelch Block Test

Interconnect the receiver and test equipment as shown in figure 1. Adjust the receiver and FM signal generator in accordance with Section 5.4 for the 12 dB SINAD signal sensitivity. Set the output level of the signal generator to zero, and measure the audio noise output power. Then set the squelch control to the maximum squelched position. Adjust the output level of the generator to 12 dB above the measured value of the receiver's tight squelch sensitivity voltage. Then increase the frequency deviation of the generator until the audio output power drops abruptly (40 dB or more). Repeat the above procedure with modulation frequencies of 0.3, 0.5, 2.5, and 3.0 kHz. The frequency deviations of the signal generator modulation are the values for squelch block.

5.6.3 Squelch Attack Time Test

Interconnect the receiver and test equipment as shown in figure 5a. With the SPST switch closed, adjust the receiver and FM signal generator in accordance with Section 5.4 for the 12 dB SINAD signal sensitivity. Set the output level of the signal generator to zero, and measure the audio noise output power.

Slowly adjust the squelch control until the audio output power drops abruptly (40 dB or more). Do not adjust the squelch control any further. Adjust the generator output level to 12 dB above the measured value of the receiver's threshold squelch sensitivity voltage. Adjust the volume control for audio output power (item M). Adjust the oscilloscope vertical controls for full scale deflection. Adjust the oscilloscope trigger controls to start the trace upon switch closure. Then close the SPST switch, and adjust the oscilloscope horizontal sweep controls so that the change in audio output level can be easily determined as a function of time. Open and close the SPST switch and photograph the trace. The time between the start of the oscilloscope trace and the time at which the audio level reached 90 percent of audio output power (item M) is the value for squelch attack time.

Note that relay pull-in and drop-out times are usually more than one-tenth the squelch attack and release times. It will generally be necessary, therefore, to measure the time differential between the two sets of contacts shown in figure 5a, and to correct the measured squelch attack and release times accordingly. Remove the receiver and FM signal generator and connect the dc power supply as shown in figure 5b. Connect the relay to the vertical input of the oscilloscope and adjust the oscilloscope as in the previous paragraph. Close the SPST switch and photograph the trace. Subtract the relay pull-in time observed in the photograph from the time determined in accordance with the previous paragraph, to obtain the squelch attack time.

5.6.4 Squelch Release Time Test

Interconnect the receiver and test equipment as shown in figure 5a. Adjust all equipment in accordance with Section 5.6.3. Then adjust the oscilloscope trigger controls to start the trace when the SPST switch is opened. Open the switch and photograph the display. The time between the start of the oscilloscope trace and the time at which the audio level falls to 10 percent of the audio output power (item M) is the value of squelch release time.

Adjust the reading, as in the second paragraph of 5.6.3, by subtracting the relay drop-out time observed in the photograph from the time determined in accordance with the previous paragraph, to obtain the squelch release time.

5.7 Audiofrequency Tests

5.7.1 Audio Output Power Test

Interconnect the receiver and test equipment as shown in figure 6. Modulate the FM signal generator with standard test modulation and set it to the standard test frequency. With the signal generator adjusted for one millivolt output, set the receiver volume control to the maximum position. Measure and record the audio output power. Repeat using plus 10 percent and minus 10 percent standard power supply voltage.

5.7.2 Audio Distortion Test

Interconnect the receiver and test equipment as shown in figure 1. Modulate the FM signal generator with standard test modulation and set the generator to the standard test frequency. With the generator adjusted for one millivolt output, adjust the receiver volume control for the audio output power (item M). Measure the audio distortion. Repeat for audio output powers of (item N) and (item O).

5.7.3 Audiofrequency Response Test

Interconnect the receiver and test equipment as shown in figure 6. Modulate the FM signal generator with standard test modulation and set it to the standard test frequency. With the signal generator adjusted for one millivolt output, adjust the receiver volume control to 50 percent of the audio output power (item M). Do not readjust the volume control for the remainder of the measurement. Reduce the generator frequency deviation to 1 kHz, and measure the audio output power for modulating frequencies of 0.3, 0.5, 2.0, and 3.0 kHz. Compute the ratio, expressed in decibels, of each of these latter power levels to the output power at 1.0 kHz.

5.7.4 Audio Hum and Noise Tests

Interconnect the receiver and test equipment as shown in figure 6. Modulate the FM signal generator with standard test modulation and set it to the standard test frequency. With the signal generator adjusted for one millivolt output, adjust the receiver volume control for audio output power (item M). Do not readjust the volume control for the remainder of the measurement. Remove the modulation from the signal generator and measure the audio hum and noise output power. Compute the ratio, expressed in decibels, of the audio output power (item M) to the hum and noise output power. This is the value for audio hum and noise (un-squelched).

Set the squelch control to its maximum squelch position. Set the output level of the generator to zero and measure the audio hum and noise output power. Calculate the ratio in decibels of the audio output power (item M) to the hum and noise output power. This is the value for audio hum and noise (squelched).

APPENDIX A--Bibliography

1. Buesing, R. T., "Modulation Methods and Channel Separation in the Land Mobile Service," IEEE Trans. on V.T., Vol. VT-19, No. 2, 187-205, (May 1970).
2. Buesing, R. T., and Shepherd, N.H., "System Performance, Compatibility, and Standards," IRE Trans. on V.C., Vol. VC-9, No. 3, 32-43, (December 1960).
3. Chaney, W. G., and Myers, R. T., "Squelch Systems--New Designs for High Performance," IEEE Trans. on V.C., Vol. VC-14, No. 1, 126-133, (March 1965).
4. Farmer, R. A., "SINAD System Design," IRE Trans. on V.C., Vol. VC-10, No. 1, pp. 103-108, (April 1961).
5. Firestone, W. L., "A Review of Communication Interference Problems," IEEE Trans. on V.C., Vol. VC-14, No. 1, 57-66, (March 1965).
6. McCormick, J. A., "15 KC Splits--A Source of Channels in the 150 MC Band," IRE Trans. on V.C., Vol. VC-9, No. 3, 94-106, (December 1960).
7. McKee, T. A., "Receiver Intermodulation: Enforcing the Square Law," IEEE Trans. on V.T., Vol. VT-18, No. 3, 141-145, (November 1969).
8. "Minimum Standards for Land Mobile Communications FM or PM Receivers 25-470 MHz," EIA Standard RS-204-A, (July 1972).
9. "Minimum Standard for Test Conditions Common to FM or PM Land Mobile Communication Equipment 25-470 MHz," EIA Standard RS-388, (January 1971).
10. "Mobile Stations FM or PM Radiotelephone Transceivers Operating in Certain VHF/UHF Bands in the Frequency Range 27-23 MHz to 470 MHz with RF Power Output Rating Not Exceeding 10 Watts," Canada Dept. of Communications Standard RSS 121, (April 15, 1971).
11. Myers, R. T., "15 KC Split Channels for the 150 MC Land Mobile Services," 1961 IRE Convention Record, Part 8, pp. 228-242.

12. Heubauer, J. R., et al., "IEEE Test Procedure for Frequency-Modulated Mobile Communications Receivers," IEEE Trans. on V.C., Vol. VT-18, No. 2, 84-99, (August 1969). Also appears as IEEE Standard No. 184, (April 1969).
13. Ornstein, W., "Technical Standards for Type Approval of Mobile Communications Equipment in Canada," 1963 IEEE International Convention Record, Part 8, Session 8, 42-48.
14. Runyon, S., "Focus on Signal Generators and Synthesizers," Electronic Design, Vol. 21, No. 10, May 10, 1973.

18.

TABLE 1

Minimum Performance Requirements for Fixed and Base Station FM Receivers

Receiver Characteristic	Minimum Requirement Frequency Band (MHz)		
	25-50	150-174	400-512
<u>Sensitivity Characteristic</u>			
A. SINAD Sensitivity	0.5 μ V	0.5 μ V	0.5 μ V
B. SINAD Sensitivity Variance (Supply Voltage Varied $\pm 10\%$)	0.5 μ V	0.5 μ V	0.5 μ V
<u>Selectivity Characteristics</u>			
C. Modulation Acceptance Bandwidth	+5 kHz	+5 kHz	+5 kHz
D. Adjacent Channel Selectivity and Desensitization	85 dB	85 dB	85 dB
E. Spurious Response Attenuation	95 dB	95 dB	95 dB
F. Intermodulation Attenuation	70 dB	75 dB	80 dB
<u>Squelch Characteristics</u>			
G. Threshold Squelch Sensitivity	0.2 μ V	0.3 μ V	0.3 μ V
H. Tight Squelch Sensitivity	2.0 μ V	3.0 μ V	3.0 μ V
I. Threshold Squelch Sensitivity Variance (Supply Voltage Varied $\pm 10\%$)	0.2 μ V	0.3 μ V	0.3 μ V
J. Squelch Block	+5 kHz	+5 kHz	+5 kHz
K. Squelch Attack Time	150 ms	150 ms	150 ms
L. Squelch Release Time	250 ms	250 ms	250 ms
<u>Audiofrequency Characteristics</u>			
M. Audio Output Power (Loudspeaker)	5 W	5 W	5 W
N. Audio Output Power (Earphones)	3 mW	3 mW	3 mW
O. Audio Output Power (Telephone Line)	12 mW	12 mW	12 mW
P. Audio Output Power Variance (Supply Voltage Varied $\pm 10\%$)	.1 dB	.1 dB	.1 dB
Q. Audio Distortion	5%	5%	5%
R. Audiofrequency Response (Loudspeaker)	-8,+2 dB	-8,+2 dB	-8,+2 dB
S. Audiofrequency Response (Earphones and Telephone Line)	-3,+1 dB	-3,+1 dB	-3,+1 dB
T. Audio Hum and Noise (Unsquelled)	45 dB	45 dB	45 dB
U. Audio Hum and Noise (Squelled)	60 dB	60 dB	60 dB

Receiver Characteristic

Minimum Requirement
Frequency Band (MHz)

25-50 150-174 400-512

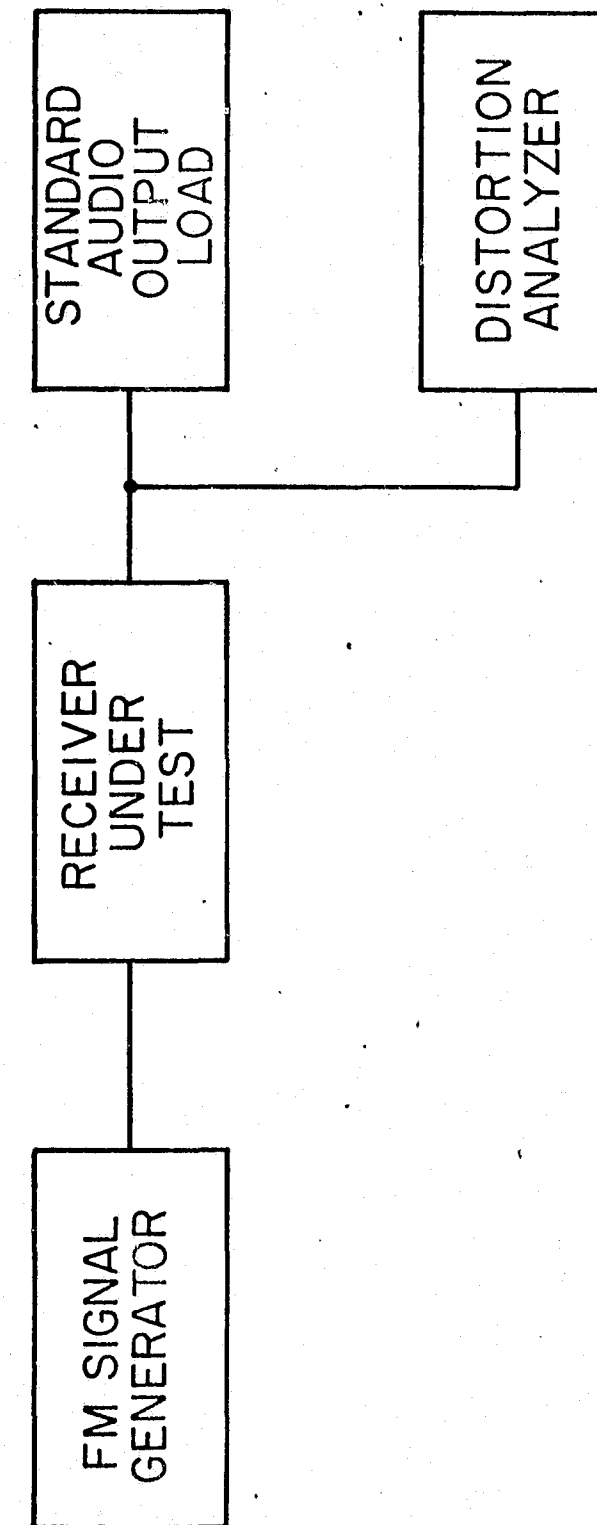
Environmental Characteristics

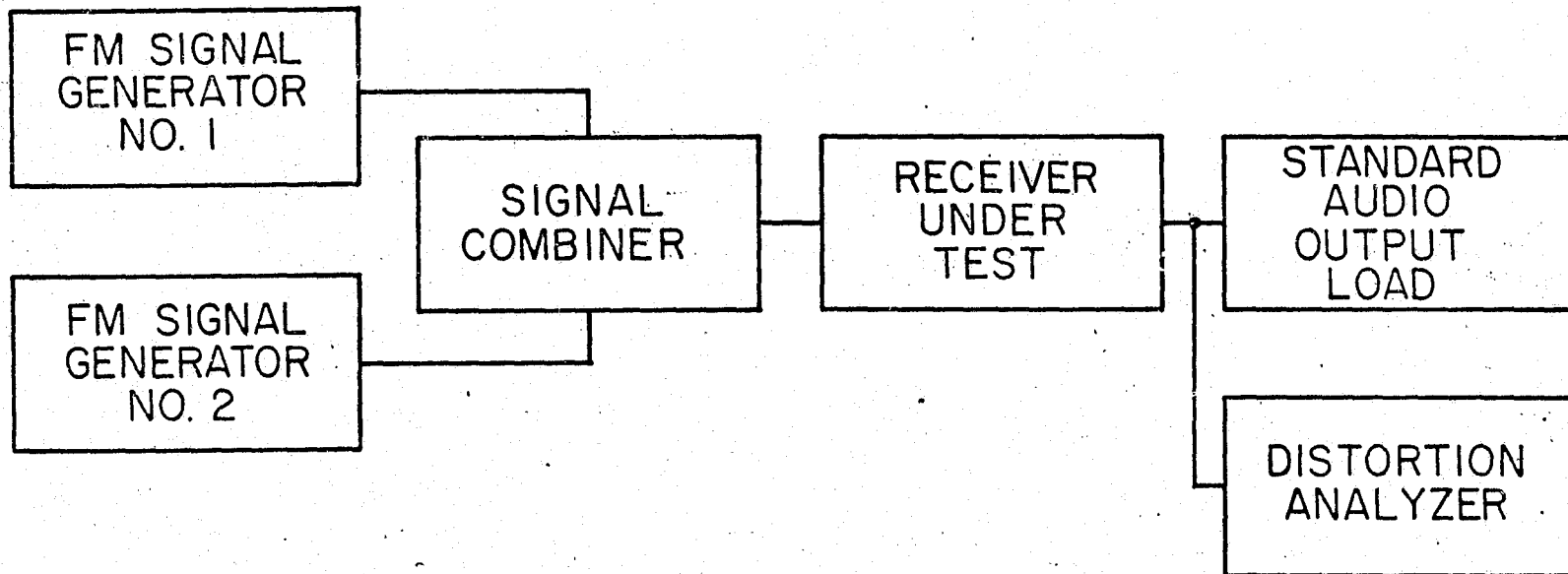
Temperature Stability

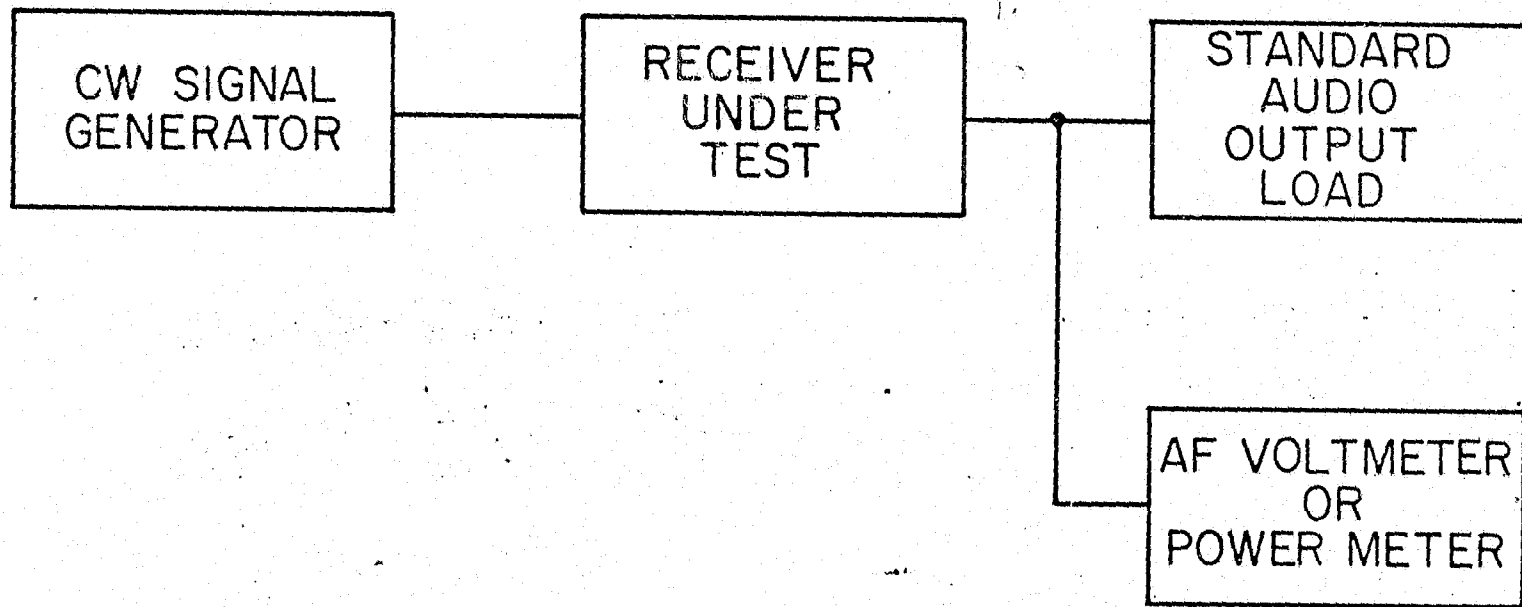
V. SINAD Sensitivity	6 dB	6 dB	6 dB
W. Modulation Acceptance Bandwidth	20%	20%	20%
X. Adjacent Channel Selectivity and Desensitization	12 dB	12 dB	12 dB
Y. Tight Squelch Sensitivity	6 dB	6 dB	6 dB
Z. Threshold Squelch Sensitivity	6 dB	6 dB	6 dB
AA. Audio Output Power	6 dB	6 dB	6 dB
AB. Audio Hum and Noise	10 dB	10 dB	10 dB
AC. Audio Distortion	9%	9%	9%

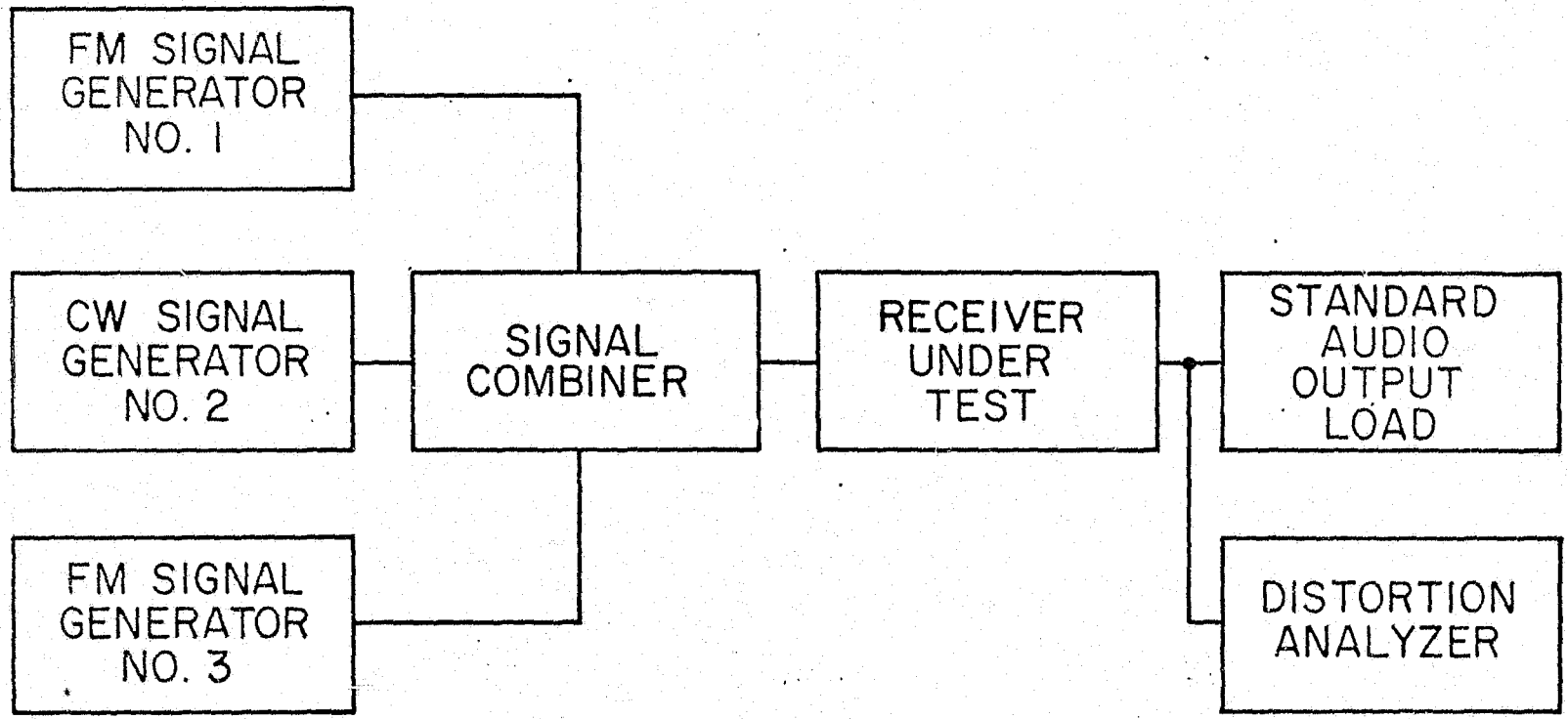
Humidity Stability

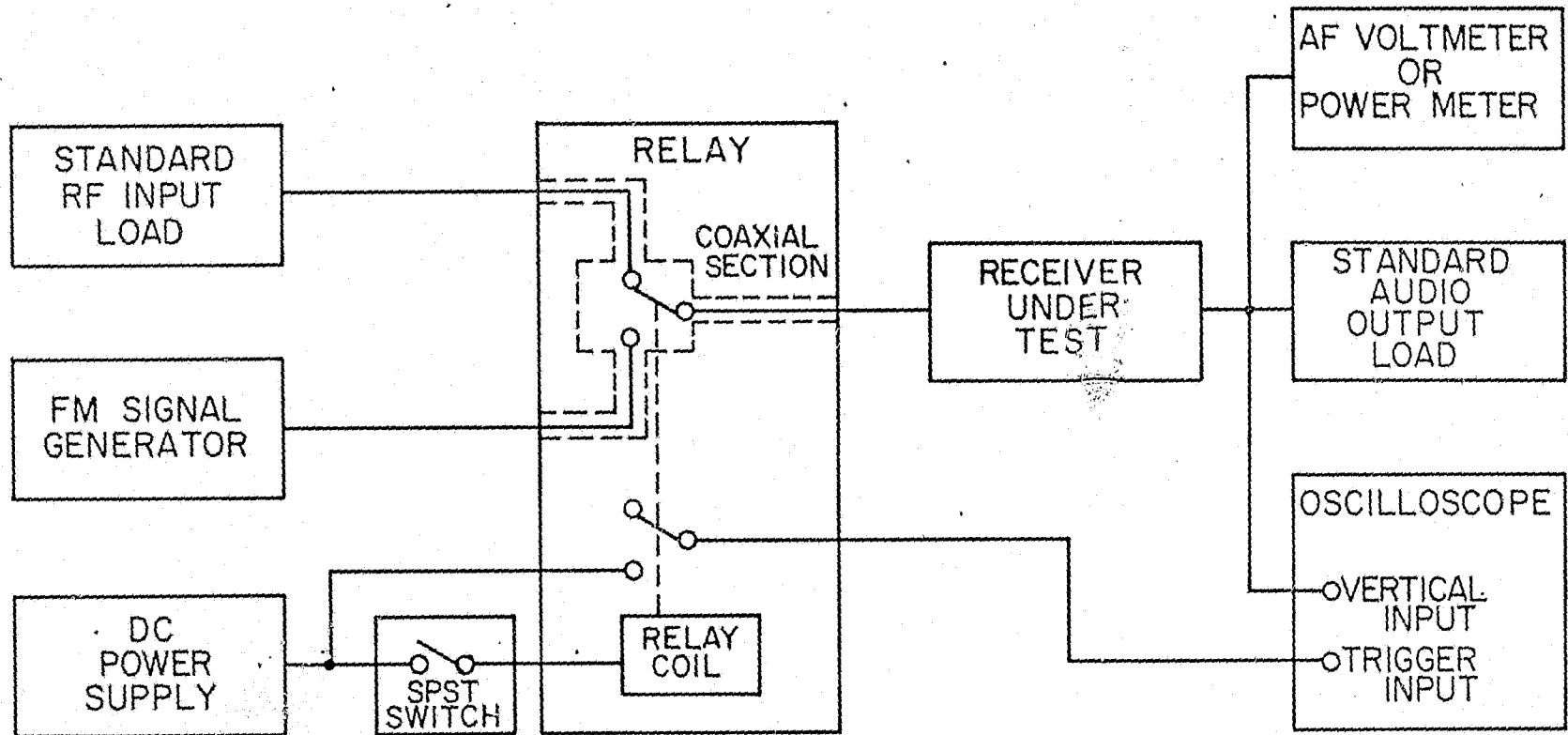
AD. SINAD Sensitivity	6 dB	6 dB	6 dB
AE. Modulation Acceptance Bandwidth	20%	20%	20%
AF. Adjacent Channel Selectivity and Desensitization	12 dB	12 dB	12 dB
AG. Tight Squelch Sensitivity	6 dB	6 dB	6 dB
AH. Threshold Squelch Sensitivity	6 dB	6 dB	6 dB
AI. Audio Output Power	3 dB	3 dB	3 dB
AJ. Audio Hum and Noise	10 dB	10 dB	10 dB
AK. Audio Distortion	9%	9%	9%

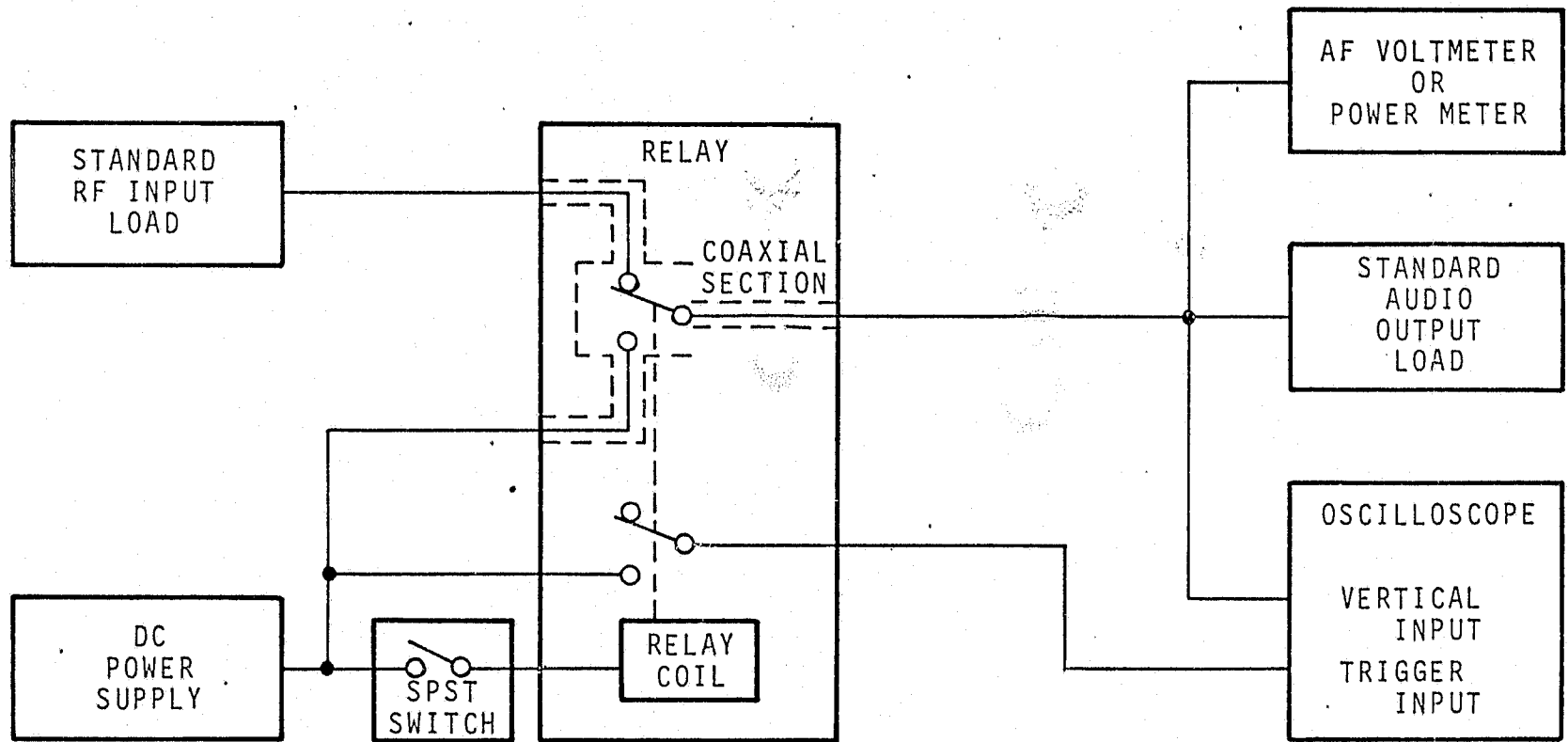












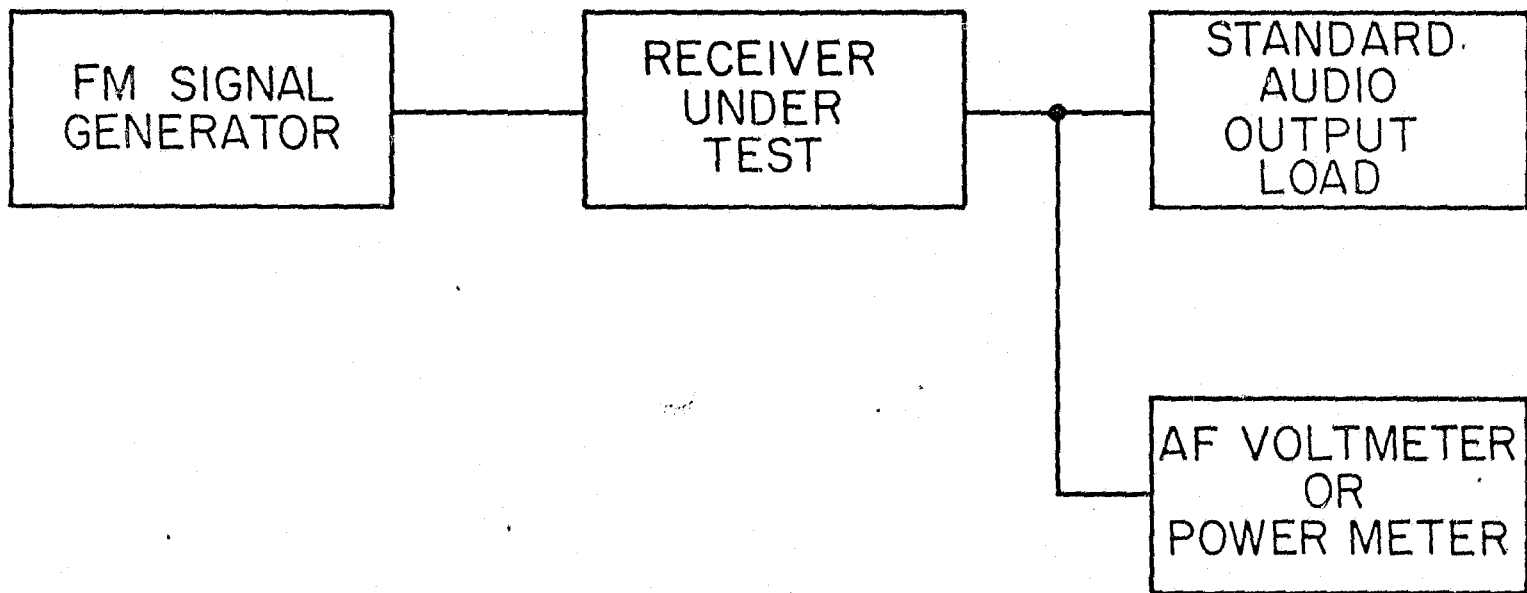


Figure Captions

1. Block diagram for SINAD sensitivity, modulation acceptance bandwidth, squelch sensitivity, squelch block and audio distortion measurements.
2. Block diagram for adjacent channel selectivity and desensitization measurement.
3. Block diagram for spurious response attenuation measurement.
4. Block diagram for intermodulation attenuation measurement.
- 5a. Block diagram for squelch attack time and squelch release time measurements.
- 5b. Block diagram for relay pull-in and drop-out time measurements.
6. Block diagram for audio output power, audiofrequency response and audio hum and noise measurements.

END